

JVC

SERVICE MANUAL

COLOUR TELEVISION

BASIC CHASSIS

MF II

AV-32Z25EUY AV-28Z25EUY

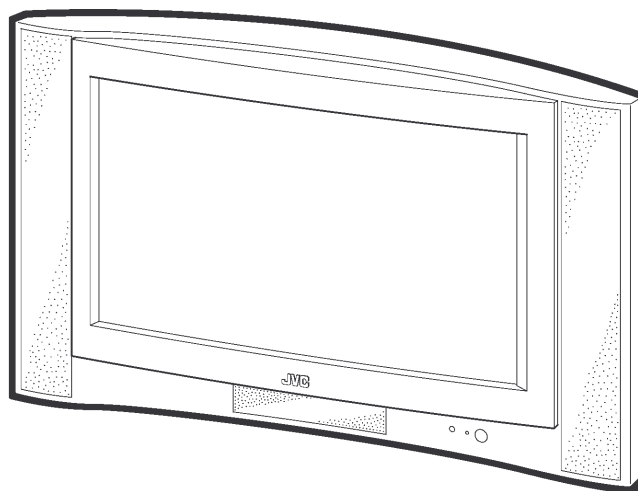

InteriArt
Natural Vision
T-V LINK

CONTENTS

■ SPECIFICATIONS	2
■ SAFETY PRECAUTIONS	4
■ FEATURES	5
■ MAIN DIFFERENCE LIST	5
■ SPECIFIC SERVICE INSTRUCTIONS	6
■ SERVICE ADJUSTMENTS	12
■ PARTS LIST	31
★ OPERATING INSTRUCTIONS	
★ STANDARD CIRCUIT DIAGRAM	2-1

SPECIFICATIONS

Item	Content	
	AV-32Z25EUY	AV-28Z25EUY
Dimensions (W × H × D)	946mm × 562mm × 551mm	854mm × 508mm × 494mm
Mass	58.0kg	43.0kg
TV RF System	CCIR (B/G,D/K,I ,L/L')	
Colour System	PAL / SECAM / NTSC (Only in EXT mode)	
Stereo System	A2 (B/G,D/K)/ NICAM (B/G,I,D/K,L)	
Teletext System	FLOF (Fastext) TOP (German system) WST(World Standard system)	
Receiving Frequency	VHF 47MHz ~ 470MHz UHF 470MHz ~ 862MHz French CATV 116MHz ~ 172MHz / 220MHz ~ 469MHz	
Intermediate Frequency	VIF Carrier 38.9MHz (B/G, D/K, I ,L)/ 33.95MHz (L') SIF Carrier 33.4MHz (5.5MHz:B/G) / 32.9MHz (6.0MHz:I) / 32.4MHz (6.5MHz:L, D/K) / 40.45MHz (6.5MHz:L')	
Colour Sub Carrier Freq.	PAL 4.43MHz SECAM 4.40625MHz/4.25MHz NTSC 3.58MHz / 4.43MHz	
Power Input	220 – 240 V AC, 50Hz	220 – 240 V AC, 50Hz
Power Consumption	300W (Max) / 161W (Avg), standby : 2.6W	292W (Max) / 150W (Avg), standby : 2.6W
Aerial Input Term	75 Ω unbalanced, Coaxial	
Picture Tube	Visible size : 76cm, Measured diagonally	Visible size : 66cm, Measured diagonally
High Voltage	+1kV 31.0kV -1.5kV (CRT cutoff, FULL mode)	
Speaker	6.5cm × 13cm oval type × 2(side), 4cm × 16cm oval type × 1(center), φ 13cm round type × 1(sub woofer)	
Audio Output	(10W + 10W) + 10W + 18W : (side L+R) + center + sub Woofer	
EXT-1/EXT-2/EXT-3 (Input / Output)	21-pin Euro connector (SCART socket)	
EXT-4 (Input)	1Vp-p 75 Ω (RCA pin jack)	
Video	500mVrms(-4dBs), High Impedance (RCA pin jack)	
Audio(L/R)	Y : 1Vp-p POSITIVE (Negative sync Provided, when terminated with 75 Ω)	
S / Video	C : 0.3Vp-p (Burst signal, when terminated with 75 Ω)	
DIGITAL AUDIO INPUT	OPTICAL × 1, COAXIAL × 1 (Dolby Digital is available.)	
AUDIO OUT (Variable)	0~1Vrms, Low Impedance:(RCA pin jack × 3)	
SURROUND REAR OUT	7.5W + 7.5W, Impedance 8 Ω (push terminal)	
Headphone jack	Stereo mini jack (φ 3.5mm)	
Remote Control Unit	RM-C58H (AAA/R03 dry battery × 2)	

Design & specifications are subject to change without notice.

★ Manufactured under license from Dolby Laboratories Licensing Corporation.
“Dolby” and the double-D symbol  are trademarks of Dolby Laboratories Licensing Corporation.

■ 21-pin Euro connector (SCART socket) : EXT-1 / EXT-2 / EXT-3

(P-P= Peak to Peak, B-W= Blanking to white peak)

Pin No.	Signal Designation	Matching Value	EXT-1	EXT-2	EXT-3
1	AUDIO R output	500mVrms(Nominal), Low impedance	○ (TV OUT)	○ (LINE OUT)	NC
2	AUDIO R input	500mVrms(Nominal), High impedance	○	○	○
3	AUDIO L output	500mVrms(Nominal), Low impedance	○ (TV OUT)	○ (LINE OUT)	NC
4	AUDIO GND		○	○	○
5	GND (B)		○	○	○
6	AUDIO L input	500mVrms(Nominal), High impedance	○	○	○
7	B input	700mV _{B-W} , 75Ω	○	○	NC
8	FUNCTION SW (SLOW SW)	Low : 0-3V, High : 8-12V, High impedance	○	○	○
9	GND (G)		○	○	○
10	SCL3		NC	○	NC
11	G input	700mV _{B-W} , 75Ω	○	○	NC
12	SDA3		NC	○	NC
13	GND (R)		○	○	○
14	GND (Y _S)		○	NC	NC
15	R / C input	R : 700mV _{B-W} , 75Ω C : 300mV _{P-P} , 75Ω	○ (only R)	○	○ (only C)
16	Ys input	Low : 0 - 0.4, High : 1 - 3V, 75Ω	○	NC	NC
17	GND(VIDEO output)		○	○	○
18	GND(VIDEO input)		○	○	○
19	VIDEO output	1V _{P-P} (Negative going sync), 75Ω	○ (TV)	○ (LINE OUT)	NC
20	VIDEO / Y input	1V _{P-P} (Negative going sync), 75Ω	○	○	○
21	COMMON GND		○	○	○

[Pin assignment]

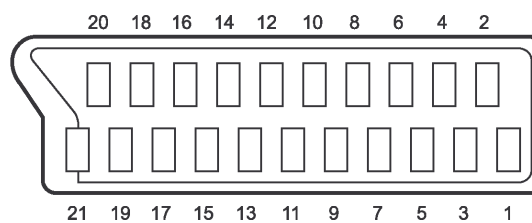

SAFETY PRECAUTIONS

1. The design of this product contains special hardware, many circuits and components specially for safety purposes. For continued protection, no changes should be made to the original design unless authorized in writing by the manufacturer. Replacement parts must be identical to those used in the original circuits. Service should be performed by qualified personnel only.
2. Alterations of the design or circuitry of the products should not be made. Any design alterations or additions will void the manufacturer's warranty and will further relieve the manufacturer of responsibility for personal injury or property damage resulting therefrom.
3. Many electrical and mechanical parts in the products have special safety-related characteristics. These characteristics are often not evident from visual inspection nor can the protection afforded by them necessarily be obtained by using replacement components rated for higher voltage, wattage, etc. Replacement parts which have these special safety characteristics are identified in the parts list of Service manual. **Electrical components having such features are identified by shading on the schematics and by (Δ) on the parts list in Service manual.** The use of a substitute replacement which does not have the same safety characteristics as the recommended replacement part shown in the parts list of Service manual may cause shock, fire, or other hazards.
4. **Don't short between the LIVE side ground and ISOLATED (NEUTRAL) side ground or EARTH side ground when repairing.**
Some model's power circuit is partly different in the GND. The difference of the GND is shown by the LIVE : (⊥) side GND, the ISOLATED(NEUTRAL) : (...) side GND and EARTH : (⊕) side GND. Don't short between the LIVE side GND and ISOLATED(NEUTRAL) side GND or EARTH side GND and never measure with a measuring apparatus (oscilloscope etc.) the LIVE side GND and ISOLATED(NEUTRAL) side GND or EARTH side GND at the same time.
If above note will not be kept, a fuse or any parts will be broken.
5. If any repair has been made to the chassis, it is recommended that the B1 setting should be checked or adjusted (See ADJUSTMENT OF B1 POWER SUPPLY).
6. The high voltage applied to the picture tube must conform with that specified in Service manual. Excessive high voltage can cause an increase in X-Ray emission, arcing and possible component damage, therefore operation under excessive high voltage conditions should be kept to a minimum, or should be prevented. If severe arcing occurs, remove the AC power immediately and determine the cause by visual inspection (incorrect installation, cracked or melted high voltage harness, poor soldering, etc.). To maintain the proper minimum level of soft X-Ray emission, components in the high voltage circuitry including the picture tube must be the exact replacements or alternatives approved by the manufacturer of the complete product.
7. Do not check high voltage by drawing an arc. Use a high voltage meter or a high voltage probe with a VTVM. Discharge the picture tube before attempting meter connection, by connecting a clip lead to the ground frame and connecting the other end of the lead through a 10kΩ 2W resistor to the anode button.
8. When service is required, observe the original lead dress. Extra precaution should be given to assure correct lead dress in the high voltage circuit area. Where a short circuit has occurred, those components that indicate evidence of overheating should be replaced. Always use the manufacturer's replacement components.

9. Isolation Check

(Safety for Electrical Shock Hazard)

After re-assembling the product, always perform an isolation check on the exposed metal parts of the cabinet (antenna terminals, video/audio input and output terminals, Control knobs, metal cabinet, screwheads, earphone jack, control shafts, etc.) to be sure the product is safe to operate without danger of electrical shock.

(1) Dielectric Strength Test

The isolation between the AC primary circuit and all metal parts exposed to the user, particularly any exposed metal part having a return path to the chassis should withstand a voltage of 3000V AC (r.m.s.) for a period of one second.

(. . . Withstand a voltage of 1100V AC (r.m.s.) to an appliance rated up to 120V, and 3000V AC (r.m.s.) to an appliance rated 200V or more, for a period of one second.)

This method of test requires a test equipment not generally found in the service trade.

(2) Leakage Current Check

Plug the AC line cord directly into the AC outlet (do not use a line isolation transformer during this check.). Using a "Leakage Current Tester", measure the leakage current from each exposed metal part of the cabinet, particularly any exposed metal part having a return path to the chassis, to a known good earth ground (water pipe, etc.). Any leakage current must not exceed 0.5mA AC (r.m.s.).

However, in tropical area, this must not exceed 0.2mA AC (r.m.s.).

● Alternate Check Method

Plug the AC line cord directly into the AC outlet (do not use a line isolation transformer during this check.). Use an AC voltmeter having 1000 ohms per volt or more sensitivity in the following manner. Connect a 1500Ω 10W resistor paralleled by a 0.15μF AC-type capacitor between an exposed metal part and a known good earth ground (water pipe, etc.). Measure the AC voltage across the resistor with the AC voltmeter. Move the resistor connection to each exposed metal part, particularly any exposed metal part having a return path to the chassis, and measure the AC voltage across the resistor. Now, reverse the plug in the AC outlet and repeat each measurement. Any voltage measured must not exceed 0.75V AC (r.m.s.). This corresponds to 0.5mA AC (r.m.s.).

However, in tropical area, this must not exceed 0.3V AC (r.m.s.). This corresponds to 0.2mA AC (r.m.s.).

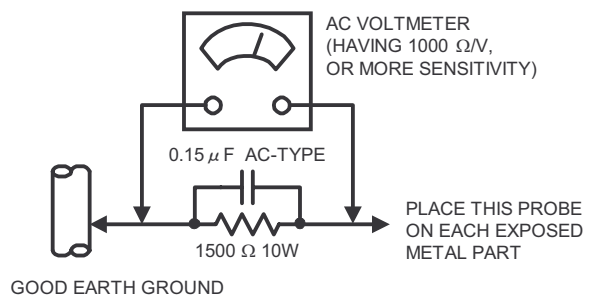

FEATURES

- New chassis design enable use of an interactive on screen control.
- The TELETEXT SYSTEM has a built-in FASTEXT (UK system), TOP (German system) and WST (world standard system) system.
- Because this TV unit corresponds to multiplex broadcast, users can enjoy music programs and sporting events with live realism. In addition, BILINGUAL programs can be heard in their original language.
- Users can make VCR dubbing of picture and sound by controlling the AV selector to select an optional source at the EXT-2 output shown in figure.

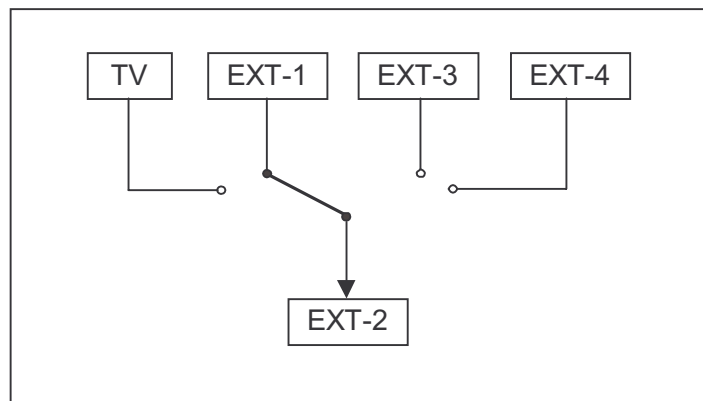

MAIN DIFFERENCE LIST

⚠	Model Name	AV-32Z25EUY	AV-28Z25EUY
⚠	Part Name		
⚠	MAIN PWB ASSY	SMF-1406A	SMF-1405A
⚠	POWER & DEF PWB ASSY	SMF-2406A	SMF-2405A
⚠	CRT SOCKET PWB ASSY	SMF-3406A	SMF-3407A
⚠	SIDE CONTROL PWB ASSY	SMF-8106A	SMF-8105A
⚠	FRONT CABINET ASSY	LC11360-005B-U	LC11313-006A-U
⚠	REAR COVER	LC11316-001B-U	LC11282-001C-U
⚠	ITC TUBE (CRT)	W76ERF042X044	W66QDE993X925
⚠	DEGAUSSING COIL	QQW0066-001	QQW0100-001
⚠	FBT	QQH0127-001	QQH0126-001
⚠	RATING LABEL	LC11548-001A-U	LC11548-002A-U
	EURO LABEL	AEM1064-030-E	AEM1064-031-E
	CUSHION ASSY	LC11361-001C	LC11318-002C
	PACKING CASE	LC10101-017A	LC10101-016A

SPECIFIC SERVICE INSTRUCTIONS

DISASSEMBLY PROCEDURE

REMOVING THE SUB WOOFER UNIT & THE REAR COVER

1. Unplug the power cord.
2. Remove the SUB WOOFER CORD from the AV TERMINAL BOARD.
3. Pull up the SUB WOOFER UNIT on the top of the rear cover upward.
4. Remove the 13 screws marked **A** as shown in the Fig. 1.
5. Withdraw the rear cover toward you.

REMOVING THE SIDE CONTROL JACK ASSEMBLY

- After removing the rear cover.
1. Remove the screw marked **B** as shown in the Fig.1.
 2. While slightly raise the side control jack assembly, remove the 2 claws under the side control jack assembly.
 3. Disconnect the connector "SR", "SL", "S", "F" and "CN016" as shown in Fig. 2.

REMOVING THE SIDE CONTROL PWB

- After removing the rear cover and side control jack assembly.
1. Remove the 3 claws **C** from back side of the side control jack assembly as shown in Fig. 2.
 2. Pull out the SIDE CONTROL PWB.

REMOVING THE CHASSIS

- After removing the rear cover.
1. Slightly raise the both sides of the chassis by hand and remove the two claws under the both sides of the chassis from the front cabinet.
 2. Withdraw the chassis backward.
(If necessary, take off the wire clamp, connectors etc.)

REMOVING THE POWER & DEF. PWB

- After removing the chassis.
1. Remove the 3 screws marked **D** as shown in Fig. 1.
 2. Remove the POWER & DEF. PWB upper.
(If necessary, take off the wire clamp, connectors etc.)

REMOVING THE CENTER SPEAKER

- After removing the rear cover and chassis.
1. Remove the 2 screws marked **E** as shown in Fig. 1.
 2. Remove the center speaker. If necessary, detach the cables.

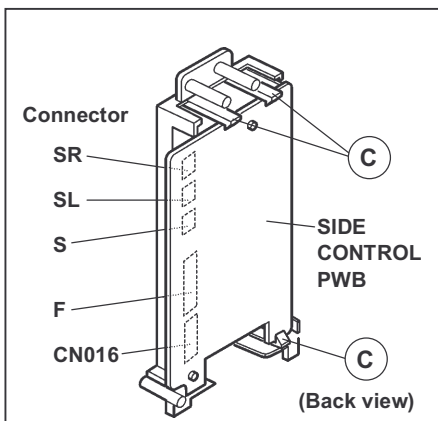

Fig. 2

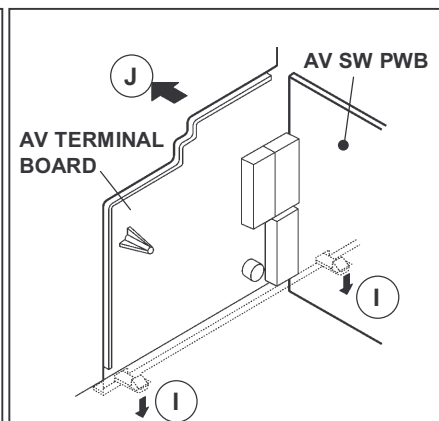

Fig. 3

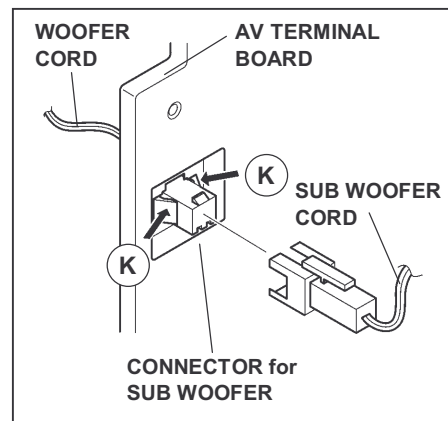

Fig. 4

REMOVING THE SIDE SPEAKER

- After removing the rear cover.
1. Remove the 2 screws marked **F**, and remove the speaker holder as shown in Fig. 1.
- NOTE** : When removing the screws marked **F** of the speaker holder remove the lower side screw first, and then remove the upper one.
2. Remove the 2 screws **G** attaching the speaker.
 3. Follow the same steps when removing the other hand speaker.

REMOVING THE AV TERMINAL BOARD

- After removing the rear cover.
1. Remove the 6 screws marked **H** as shown in the Fig. 1.
 2. Remove the 2 claws marked **I** under the CHASSIS as shown in Fig. 3.
 3. Remove the AV TERMINAL BOARD slightly in the direction of arrow **J** as shown in Fig. 3.
 4. After removing the claw **K** on the connector for SUB WOOFER, pull out the connector for SUB WOOFER. (Fig. 4)

CHECKING THE PW BOARD

To check the back side of the PW Board.

- 1) Pull out the chassis. (Refer to REMOVING THE CHASSIS).
- 2) Erect the chassis vertically so that you can easily check the back side of the PW Board.

[CAUTION]

- When erecting the chassis, be careful so that there will be no contacting with other PW Board.
- Before turning on power, make sure that the wire connector is properly connected.
- When conducting a check with power supplied, be sure to confirm that the CRT EARTH WIRE (BRAIDED ASS'Y) is connected to the CRT SOCKET PW board.

WIRE CLAMPING AND CABLE TYING

1. Be sure to clamp the wire.
2. Never remove the cable tie used for tying the wires together. Should it be inadvertently removed, be sure to tie the wires with a new cable tie.

REMOVING THE CRT

- * Replacement of the CRT should be performed by 2 or more persons.
 - After removing the cover, chassis etc.,
1. Putting the CRT change table on soft cloth, the CRT change table should also be covered with such soft cloth (shown in Fig.5).
 2. While keeping the surface of CRT down, mount the TV set on the CRT change table balanced will as shown in Fig.6.
 3. Remove 4 screws marked by arrows with a box type screw driver as shown in Fig.6.
- Since the cabinet will drop when screws have been removed, be sure to support the cabinet with hands.
4. After 4 screws have been removed, put the cabinet slowly on cloth (At this time, be carefully so as not to damage the front surface of the cabinet) shown in Fig.7.
- The CRT should be assembled according to the opposite sequence of its dismounting steps.
- * The CRT change table should preferably be smaller than the CRT surface, and its height be about 35cm.

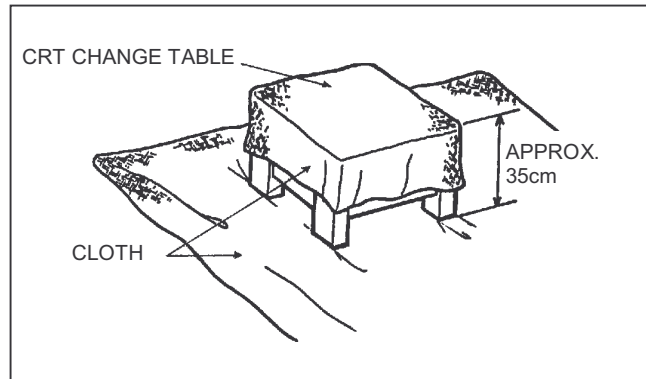

Fig. 5

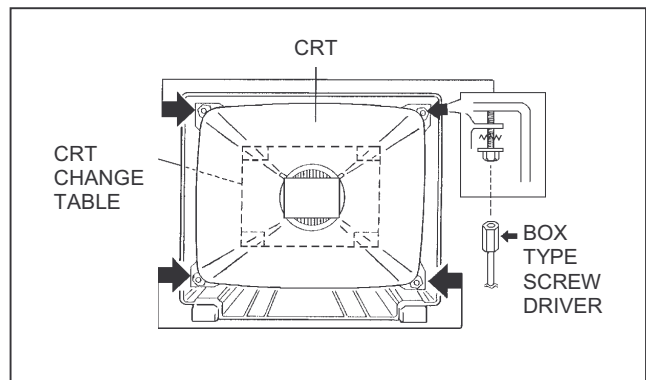

Fig. 6

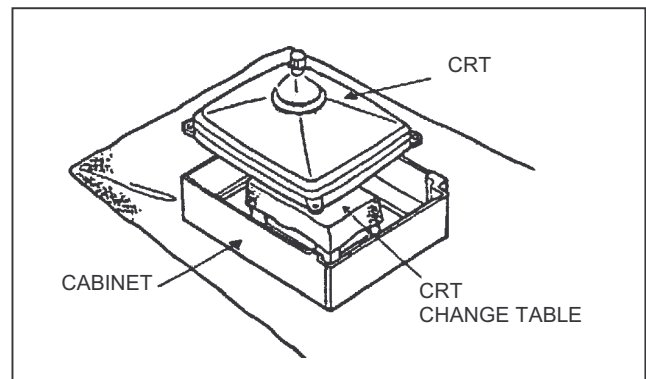
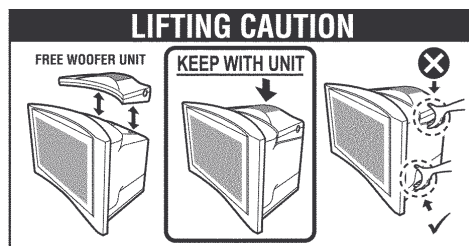

Fig. 7

CAUTION

- The woofer unit is mounted on the TV. Always move the TV and woofer unit together when removing the TV from the box, or when moving the woofer unit.
- If the TV is tilted during movement the woofer unit may fall. Be careful to keep the TV level when moving it.
- Do not grip the woofer unit when moving the TV.
- Do not place objects on the woofer unit duct.



REPLACEMENT OF CHIP COMPONENT

■ CAUTIONS

1. Avoid heating for more than 3 seconds.
2. Do not rub the electrodes and the resist parts of the pattern.
3. When removing a chip part, melt the solder adequately.
4. Do not reuse a chip part after removing it.

■ SOLDERING IRON

1. Use a high insulation soldering iron with a thin pointed end of it.
2. A 30w soldering iron is recommended for easily removing parts.

■ REPLACEMENT STEPS

1. How to remove Chip parts

◆ Resistors, capacitors, etc

- (1) As shown in the figure, push the part with tweezers and alternately melt the solder at each end.

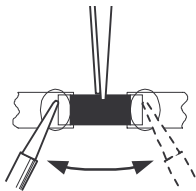

- (2) Shift with tweezers and remove the chip part.

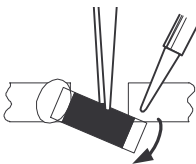

◆ Transistors, diodes, variable resistors, etc

- (1) Apply extra solder to each lead.



- (2) As shown in the figure, push the part with tweezers and alternately melt the solder at each lead. Shift and remove the chip part.

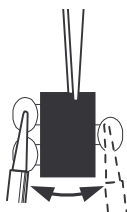

Note : After removing the part, remove remaining solder from the pattern.

2. How to install Chip parts

◆ Resistors, capacitors, etc

- (1) Apply solder to the pattern as indicated in the figure.

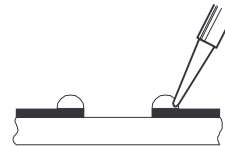

- (2) Grasp the chip part with tweezers and place it on the solder. Then heat and melt the solder at both ends of the chip part.

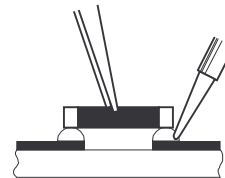

◆ Transistors, diodes, variable resistors, etc

- (1) Apply solder to the pattern as indicated in the figure.
- (2) Grasp the chip part with tweezers and place it on the solder.
- (3) First solder lead **A** as indicated in the figure.

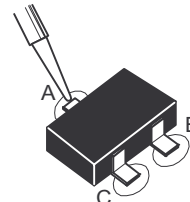

- (4) Then solder leads **B** and **C**.

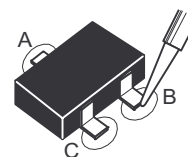

REPLACEMENT OF MEMORY ICs

1. Memory ICs

This TV use memory ICs. In the memory ICs, there are memorized data for correctly operating the video and deflection circuits. When replacing memory ICs, be sure to use ICs written with the initial values of data.

2. Procedure for replacing memory ICs

PROCEDURE	
(1) Power off	Switch the power off and unplug the power cord from the outlet.
(2) Replace ICs.	Be sure to use memory ICs written with the initial data values.
(3) Power on	Plug the power cord into the outlet and switch the power on.
(4) Check and set SYSTEM CONSTANT SET:	<p>* It must not adjust without signal.</p> <ol style="list-style-type: none"> 1) Press the INFORMATION key and the MUTING key of the REMOTE CONTROL UNIT simultaneously. 2) The SERVICE MENU screen of Fig. 1 will be displayed. 3) While the SERVICE MENU is displayed, press the INFORMATION key and MUTING key simultaneously, and the SYSTEM CONSTANT SET screen of Fig. 2 will be displayed. 4) Check the setting values of the SYSTEM CONSTANT SET of Table 1. If the value is different, select the setting item with the FUNCTION UP/DOWN key, and set the correct value with the FUNCTION +/- key. 5) Press the MENU key to memorize the setting value. 6) Press the INFORMATION key twice, and return to the normal screen.
(5) Setting of receive channels	<p>Set the receive channel. For setting, refer to the OPERATING INSTRUCTIONS.</p>
(6) User settings	<p>Check the user setting values of Table 2, and if setting value is different, set the correct value. For setting, refer to the OPERATING INSTRUCTIONS.</p>
(7) Setting of SERVICE MENU	<p>Verify the setting items of the SERVICE MENU of Table 3, and reset where necessary. For setting, refer to the SERVICE ADJUSTMENTS.</p>





SERVICE MENU	
1. IF	2. V/C
3. AUDIO	4. DEF
5. VSM PRESET	6. STATUS
7. PIP	8. ---
9. SHIPPING (OFF)	0. BUS FREE
1-9 : SELECT	i : EXIT

Fig.1

SYSTEM CONSTANT SET	
1. DESTINATION	EU
-/+  : STORE i : EXIT	

Fig.2

NAME OF REMOTE CONTROL KEY

Names of key	key
INFORMATION	
MUTING	
MENU	
FUNCTION UP/DOWN	
FUNCTION +/-	

SETTING VALUES OF SYSTEM CONSTANT SET (TABLE 1)

Setting item	Setting content	Setting value	Setting item	Setting content	Setting value
DESTINATION	EU → EK → EI	EU	DOLBY	NO → YES	YES
CRT TYPE	16:9 → 4:3	16:9	BBE	NO → YES	NO
PURITY	NO → YES	NO	PROGRESSIVE	NO → YES	YES
PICTURE TILT	NO → YES	YES	TDA9178	NO → YES	YES
DIGIPURE PRO	NO → YES	YES	TONE IC	NO → YES	YES
PIP	NO → 1TUNER → 2TUNER	NO	FLAT	NO → YES	YES
PIC&TEXT	NO → YES	YES			

USER SETTING VALUES (TABLE 2)

PICTURE SETTING		SOUND SETTING	
TINT	COOL	BASS	CENTER
CONTRAST / BRIGHT	REFER to VSM PRESET	TREBLE	+3
SHARP / COLOUR		BALANCE	CENTER
PICTURE FEATURES		SURROUND	
DIGITAL VNR	AUTO	DIGITAL SURROUND	OFF
DIGIPURE PRO	AUTO	3D PHONIC	
COLOUR SYSTEM	TV : According to preset CH EXT : AUTO	TV SPEAKER	LEFT / CENTER / RIGHT
4:3 AUTO ASPECT	PANORAMIC	SUB WOOFER	INT
EXT SETTING		LEVEL	CENTER
ID	BLANK	VOLUME	YELLOW POINT
S-IN	BLANK	DOLBY SURROUND	
DUBBING	EXT-1 → EXT-2	TV SPEAKER	LEFT / CENTER / RIGHT
FEATURES		REAR SPEAKER	ON
SLEEP TIMER	OFF	SUB WOOFER	INT
BLUE BACK	ON	TEST TONE	OFF
INSTALL		LEFT	YELLOW POINT
LANGUAGE	ENGLISH	CENTER	
EDIT/MANUAL	PRESET CH only The others : BLANK	RIGHT	
		SURROUND	
		DELAY TIME	0

SERVICE MENU SETING ITEMS (TABLE 3)

* : Do not adjust

Setting item	Setting value	Setting item	Setting value
1. IF	1. VCO 2. ATT ON/OFF		1. V-SHIFT 2. V-SIZE 3. H-CENT 4. H-SIZE 5. TRAPEZ 6. EW-PIN 7. COR-PIN 8. COR-UP 9. COR-LO 10. ANGLE 11. BOW 12. V-S.CR 13. V-LIN
2. V / C	1. RGB BLK 2. WDR R 3. WDR G 4. WDR B 5. BRIGHT 6. CONTRAST 7. COLOUR 8. HUE 9. SHARP 10. VCO ADJ. 11. VID AGC 12. SYNC SLI 13. A MOVIE	4. DEF.	
3. AUDIO (Do not adjust)	1. ERR LIMIT 2. A2 ID THR 3. Q-PEAK	5. VSM PRESET COOL NORMAL WARM	1. CONT. 2. BRIGHT 3. SHARP 4. COLOUR 5. HUE 6. WDR R 7. WDR G 8. WDR B
9. SHIPPING (Do not adjust)	ON/OFF	6. STATUS (Do not adjust)	VPS PDC

SERVICE ADJUSTMENTS

BEFORE STARTING SERVICE ADJUSTMENT

1. There are 2 ways of adjusting this TV: One is with the REMOTE CONTROL UNIT and the other is the conventional method using adjustment parts and components.
2. The setting (adjustment) using the REMOTE CONTROL UNIT is made on the basis of the initial setting values. The setting values which adjust the screen to the optimum condition can be different from the initial setting values.
3. Make sure that connection is correctly made to AC power source.
4. Turn on the power of the TV and measuring instrument for warming up for at least 30 minutes before starting adjustment.
5. If the receive or input signal is not specified, use the most appropriate signal for adjustment.
6. Never touch parts (such as variable resistors, transformers and condensers) not shown in the adjustment items of this service adjustment.
7. Preparation for adjustment (presetting):
Unless otherwise specified in the adjustment items, preset the following functions with the REMOTE CONTROL UNIT.

- Setting position

PICTURE MODE (VSM)	NORMAL
SLEEP TIMER	OFF
STONE BALANCE	CENTER
ZOOM	FULL

MEASURING INSTRUMENT AND FIXTURES

1. DC voltmeter (or digital voltmeter)
2. Oscilloscope
3. Signal generator (Pattern generator) [PAL / SECAM / NTSC]
4. Remote control unit

ADJUSTMENT ITEMS

- Checking items.
- Adjustment of FOCUS & SCREEN
- VSM preset adjust setting.
- VIDEO / CHROMA circuit adjustment.
- DEFLECTION circuit adjustment.
- AUDIO circuit adjustment. (Do not adjust)

ADJUSTMENT LOCATIONS

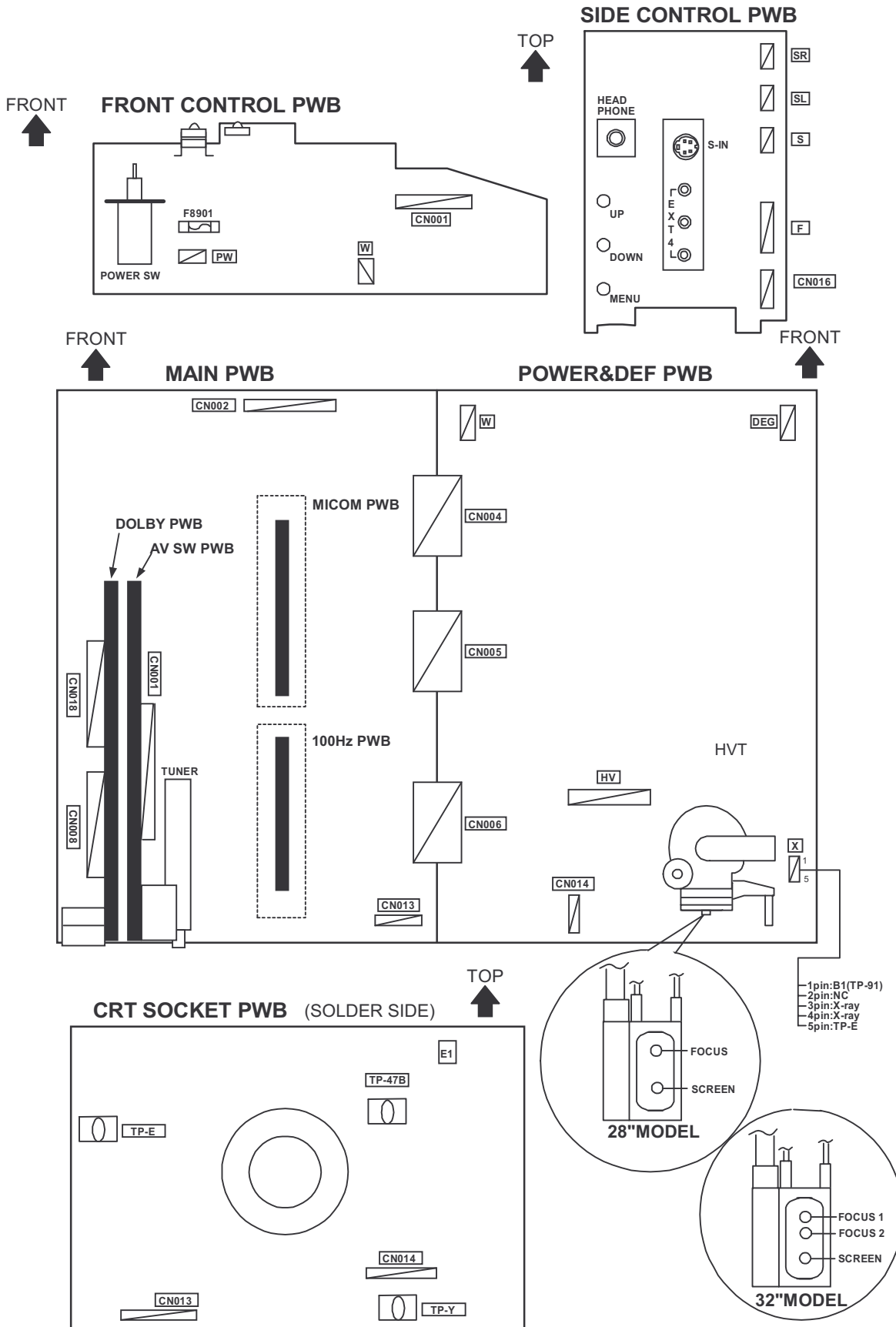

BASIC OPERATION SERVICE MENU

1. TOOL OF SERVICE MENU OPERATION

Operate the SERVICE MENU with the REMOTE CONTROL UNIT.

2. SERVICE MENU ITEMS

With the SERVICE MENU, various settings (adjustments) can be made, and they are broadly classified in the following items of settings (adjustments):

- (1) **1. IF** This mode adjusts the setting values of the IF circuit.
- (2) **2.V/C** This mode adjusts the setting values of the VIDEO / CHROMA circuit.
- (3) **3.AUDIO** This mode adjusts the setting values of the multiplicity SOUND circuit.
- (4) **4.DEF** This mode adjusts the setting values of the DEFLECTION circuit for each aspect mode given below.
 - FULL (100/120Hz)
 - PANORAMIC (100/120Hz)
 - SUBTITLE (100/120Hz)
 - COMPRESS (Fixed value) (100/120Hz)
- (5) **5.VSM PRESET** This mode adjusts the initial setting values of COOL, NORMAL and WARM.
(VSM : Video Status Memory)

3. BASIC OPERATION OF SERVICE MENU

(1) How to enter SERVICE MENU

Press the "INFORMATION" key and the "MUTING" key of the REMOTE CONTROL UNIT simultaneously, and the SERVICE MENU screen of Fig.1 will be displayed.

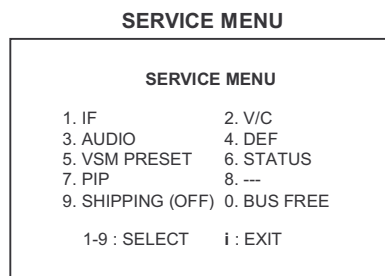

Fig.1

(2) Selection of SUB MENU SCREEN

Press one of keys 1~5 of the REMOTE CONTROL UNIT and select the SUB MENU SCREEN (See Fig. 3), from the SERVICE MENU.

SERVICE MENU → SUB MENU

- 1. IF
- 2. V / C
- 3. AUDIO
- 4. DEF.
- 5. VSM PRESET
- 6. STATUS
- 7. PIP
- 8. ---
- 9. SHIPPING (OFF)
- 0. BUS FREE

* : Do not adjust

NAME OF REMOTE CONTROL KEY	
Names of key	key
INFORMATION	
MUTING	
MENU	
FUNCTION UP/DOWN	
FUNCTION +/-	

Fig.2

(3) Method of Setting

1) Method of Setting **1.IF**

[VCO] It must not adjust without signal.

① 1 Key Select 1.IF.

② 1 Key Select 1.VCO(CW)

Make sure that the arrow position between the ABOVE REF and BELOW REF.

③ INFORMATION Key Return to the SERVICE MENU screen.

2) Method of setting **2.V/C, 3.AUDIO, 4.DEF** and **5.VSM PRESET**.

① 2~5 Key Select one from **2.V/C, 3.AUDIO, 4.DEF** and **5.VSM PRESET**.

② FUNCTION UP / DOWN (▲/▼) Key Select setting items.

③ FUNCTION +/- (◀/▶) Key Set (adjust) the setting values of the setting items.

④ MENU Key Memorize the setting value.

(Before storing the setting values in memory, do not press the CH, TV, POWER ON / OFF key - if you do, the values will not be stored in memory.)

⑤ INFORMATION Key Return to the **SERVICE MENU** screen.

3) Do not setting **6.STATUS, 7.PIP, 8.---** , **9.SHIPPING(OFF) & 0.BUS FREE**.

(4) **Release of SERVICE MENU**



1) After completing the setting, return to the SERVICE MENU, then again press the INFORMATION key.

ADJUSTMENTS

CHECK ITEM

Item	Measuring instrument	Test point	Adjustment part	Description
B1 Power Supply check	Signal generator DC voltmeter Remote control unit	TP-91(B1) TP-E(...) [X connector on POWER DEF PWB]	1.RGB BLK	<ol style="list-style-type: none"> 1. Receive a any broadcast. 2. Push the "ZOOM" key and select the FULL mode. 3. Select 2. V/C from the SERVICE MENU. 4. Select 1. RGB BLK with function UP / DOWN (▲/▼) key. 5. Press the function + (▶) key to find the cut off screen (Black screen). 6. Connect a DC voltmeter to TP-91(B1) and TP-E(...). 7. Make sure that the voltage is DC139.9 ±2.0V. 8. Press the function - (◀) key to return to service menu..
High Voltage check	Signal generator DC volunteeer Remote control unit	CRT anode Chassis GND	1.RGB BLK	<ol style="list-style-type: none"> 1. Receive a any broadcast. 2. Push the "ZOOM" key and select the FULL mode. 3. Select 2. V/C from the SERVICE MENU. 4. Select 1. RGB BLK with function UP / DOWN (▲/▼) key. 5. Press the function + (▶) key to find the cut off screen (Black screen). 6. Connect a DC voltmeter to CRT ANODE and chassis GND. 7. Make sure that the voltage is DC 31.0kV ^{+1kV} _{-1.5kV} . 8. Press the function - (◀) key to return to service menu.
VCO check	Remote control unit		1. VCO	<ul style="list-style-type: none"> ● Under normal conditions, no adjustment is required. ● Confirmation adjustment. <ol style="list-style-type: none"> 1. Select 1.IF from the SERVICE MENU. 2. Then select 1.VCO from the IF SERVICE MENU. 3. Receive any broadcast. 4. Check the arrow (←) position between the ABOVE REF. and BELOW REF. <div style="text-align: center;"> </div>

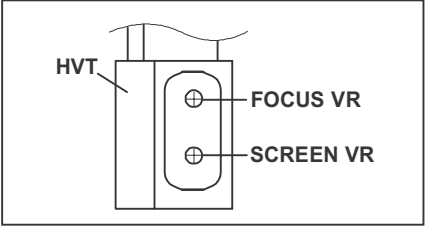
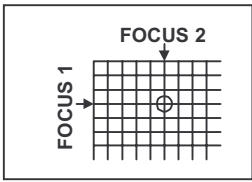
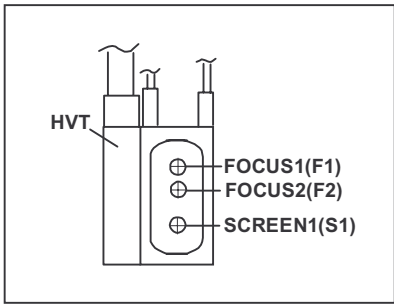
FOCUS & SCREEN ADJUSTMENT

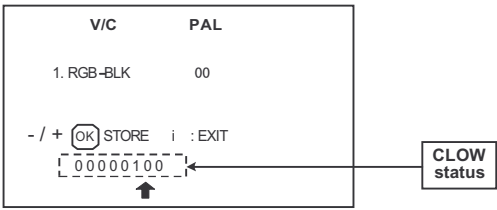
Item	Measuring instrument	Test point	Adjustment part	Description
FOCUS adjustment [28" MODEL]	Signal generator		FOCUS VR [In HVT]	[28" MODEL] 1. Receive a cross-hatch signal. 2. Press the "ZOOM" key and select the FULL mode. 3. While watching the screen, adjust the FOCUS VR to make the vertical and horizontal lines as fine and sharp as possible. 4. Make sure that when the screen is darkened, the lines remain in good focus.
				
FOCUS adjustment [32" MODEL]	Signal generator		FOCUS 1 FOCUS 2 [In HVT]	[32" MODEL] 1. Receive a cross-hatch signal. 2. Push the "ZOOM" key and select the FULL mode. 3. By turning the FOCUS2 VR, and adjust the picture so that the "O" part vertical line may become thinnest. 4. By turning the FOCUS1 VR, and adjust the picture so that the 3rd horizontal line from the upper may become uniform at the line center and its periphery. 5. Carry out adjustment by repeating the steps 3 and 4 above. 6. Make sure that when the screen is darkened, the lines remain in good focus.
				
				
SCREEN Adjustment	Signal generator		SCREEN VR [In HVT]	1. Receive a whole black signal 2. Press the "ZOOM" key and select the FULL mode. 3. Select 2. V/C from the SERVICE MENU. 4. Turn the SCREEN VR clockwise from the full counter clockwise position and stop it at the point where "CLOW" status (marked  in Fig.) changes from 1 to 0 to 1 (which is indicated at the 3rd column from the right.) 5. Then turn the SCREEN VR counterclockwise, and stop where the "CLOW" status changes 1 to 0 * "CLOW" : control loopout of window.
				

VSM PRESET ADJUST SETTING

Item	Measuring instrument	Test point	Adjustment part	Description
VSM PRESET setting	Remote control unit		1. CONT. 2. BRIGHT 3. SHARP 4. COLOUR 5. HUE 6. WDR R 7. WDR G 8. WDR B	1. Select COOL with the MENU key of the remote control unit. 2. Select 5.VSM PRESET from the SERVICE MENU. 3. Adjust the FUNCTION UP/DOWN (▲/▼) and -/+ (◀/▶)key to bring the set values of 1.CONT ~ 8. WDR B to the values shown in the table. 4. Press the MENU key and memorize the set value. 5. Respectively select the VSM PRESET mode for NORMAL and WARM, and make similar adjustment as in 3 above. 6. Press the MENU key and memorize the set value. * Refer to OPERATING INSTRUCTIONS for the PICTURE MODE.

		1.CONT.	2.BRIGHT	3.SHARP	4.COLOUR	5.HUE	6.WDR R	7.WDR G	8.WDR B
32"	COOL	+16	0	-10	0	0	-25	-12	0
	NORMAL	0	0	-10	0	0	0	0	0
	WARM	-13	0	-10	-1	0	+5	0	0
28"	COOL	+13	0	-12	0	0	-28	-12	0
	NORMAL	-3	0	-12	0	0	0	0	0
	WARM	-13	0	-12	-1	0	+5	0	0

SETTING VALUES OF VSM PRESET

--	--	--	--	--	--	--	--	--	--

VIDEO / CHROMA CIRCUIT ADJUSTMENT

The setting (adjustment) using the REMOTE CONTROL UNIT is made on the basis of the initial setting values.
The setting values which adjust the screen to the optimum condition can be different from the initial setting values.

Setting Item (Adjustment item)	Initial setting value		
	PAL	SECAM	NTSC
2. V/C			
1.RGB BLK	—	—	—
2.WDR R	0000	←	←
3.WDR G	0000	←	←
4.WDR B (Do not move)	-012	←	←
5.BRIGHT	0000	←	←
6.CONTRAST	0060	←	←
7.COLOUR	0000	←	←
8.HUE	—	—	0020
9.SHARP (Do not move)	0007	←	←
10.VCO ADJ. (Do not move)	—	—	—
11.VID AGC (Do not move)	0000	←	←
12.SYC SLI (Do not move)	0007	←	←
13.A MOVIE (Do not move)	0001	←	←

* : Do not move

Item	Measuring instrument	Test point	Adjustment part	Description
WHITE BALANCE (High Light) adjustment	Signal generator Remote control unit		2. WDR R 3. WDR G 4. WDR B (Do not move)	<ul style="list-style-type: none"> ● Set the PICTURE MODE to NORMAL. <ol style="list-style-type: none"> 1. Receive a black and white signal (colour off). 2. Select 2.V/C from the SERVICE MENU. 3. Modify 2. WDR R and 3.WDR G data to adjust the white balance (high light). 4. Press the MENU key and memorize the set value. 5. Change the contrast and brightness with the remote control up & down from low–light to high–light and check that the tracking of the white balance is good.
SUB BRIGHT adjustment	Remote control unit		5. BRIGHT	<ol style="list-style-type: none"> 1. Receive any broadcast. 2. Select 2.V/C from the SERVICE MENU. 3. Select 5.BRIGHT with the FUNCTION UP/DOWN (▲/▼) key. 4. Set the initial setting value with the FUNCTION -/+ (◀/▶)key. 5. If the brightness is not the best with the initial setting value, make fine adjustment until you get the best brightness. 6. Press the MENU key and memorize the set value.
SUB CONT. Adjustment	Remote control unit		6.CONT.	<ol style="list-style-type: none"> 1. Receive any broadcast. 2. Select 2.V/C from the SERVICE MENU. 3. Select 6.CONT with the FUNCTION UP/DOWN (▲/▼) key. 4. Set the initial setting value with the FUNCTION -/+ (◀/▶) key. 5. If the contrast is not the best with the initial setting value, make fine adjustment until you get the best contrast. 6. Press the MENU key and memorize the set value.

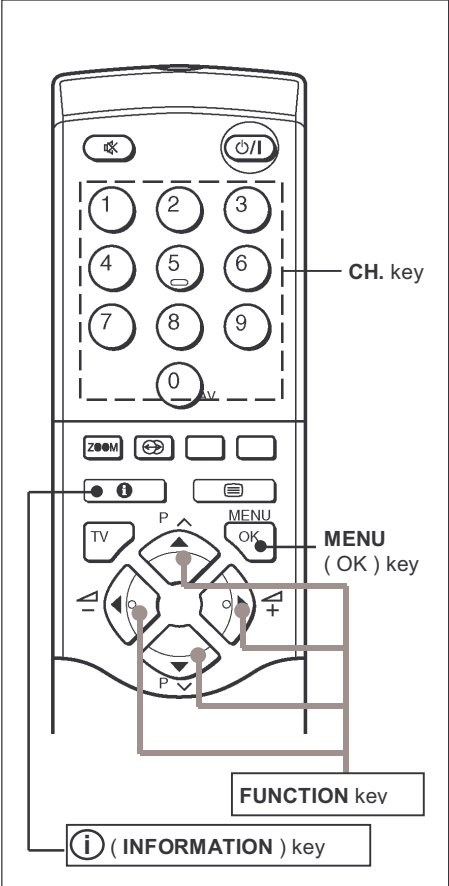
Item	Measuring instrument	Test point	Adjustment part	Description
SUB COLOUR I adjustment	Remote control unit		7.COLOUR (PAL~NTSC)	[Method of adjustment without measuring instrument]
 <p style="text-align: center;">REMOTE CONTROL KEY</p>				PAL COLOUR (PAL COLOUR) 1. Receive PAL broadcast. 2. Select 2.V/C from the SERVICE MENU. 3. Select 7.COLOUR with the FUNCTION UP/DOWN (▲/▼) key. 4. Set the initial setting value for PAL COLOUR with the FUNCTION +/- (◀/▶) key. 5. If the colour is not the best with the initial set value, make fine adjustment until you get the best colour. 6. Press the MENU key and memorize the set value.
				SECAM COLOUR (SECAM COLOUR) 1. Receive a SECAM broadcast. 2. Make fine adjustment of SECAM COLOUR in the same manner as for above.
				NTSC COLOUR (NTSC 3.58 COLOUR) 1. Input a NTSC 3.58MHz COMPOSITE VIDEO signal from the EXT terminal. 2. Make similar fine adjustment of NTSC 3.58 COLOUR in the same manner as for above.
				(NTSC 4.43COLOUR) 1. When NTSC 3.58 COLOUR set, NTSC 4.43 COLOUR will automatically set.

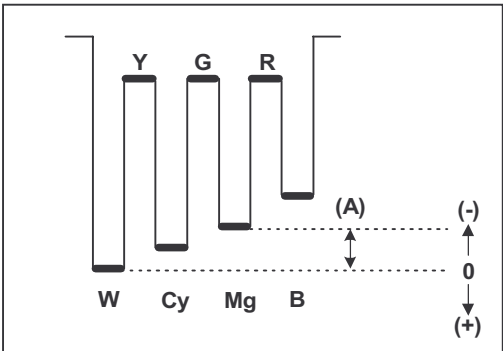
Item	Measuring instrument	Test point	Adjustment part	Description						
SUB COLOUR II adjustment	Signal generator	TP-47B TP-E(...)	7.COLOUR (PAL~NTSC)	[Method of adjustment using measuring instrument]						
	Oscilloscope	[CRT SOCKET PWB]	PAL COLOUR	(PAL COLOUR) 1. Receive a PAL full field colour bar signal (75% white). 2. Select 2.V/C from the SERVICE MENU. 3. Select 7.COLOUR with the FUNCTION UP/DOWN (▲/▼) key. 4. Set the initial setting value of PAL COLOUR with the FUNCTION -/+ (◀/▶) key. 5. Connect the oscilloscope between TP-47B and TP-E(...). 6. Adjust PAL COLOUR and bring the value of (A) in the illustration to the values as shown given billow (Voltage difference between white (W) and blue (B)). 7. Press the MENU key and memorize the setting value.						
	Remote control unit			<table border="1" style="margin-left: auto; margin-right: auto;"> <tr> <td>VOLTAGE (W-B)</td> <td>+5V</td> </tr> </table>	VOLTAGE (W-B)	+5V				
	VOLTAGE (W-B)	+5V								
		SECAM COLOUR	(SECAM COLOUR) 1. Receive a SECAM full field colour bar signal (75% white). 2. Set the initial setting value of SECAM COLOUR with the FUNCTION -/+ (◀/▶) key. 3. Adjust SECAM COLOUR and bring the value of (A) in the illustration to the values as shown given billow (Voltage difference between white (W) and blue (B)). 4. Press the MENU key and memorize the setting value.							
			NTSC COLOUR	(NTSC 3.58 COLOUR) 1. Input a NTSC 3.58MHz COMPOSITE VIDEO signal (full field colour bar with 75% white) from the EXT terminal. 2. Set the initial setting value of NTSC 3.58 COLOUR with the FUNCTION -/+ (◀/▶) key. 3. Adjust NTSC 3.58 COLOUR and bring the value of (A) in the illustration to the values as shown given billow (Voltage difference between white (W) and blue (B)). 4. Press the MENU key and memorize the setting value.						
										
				<table border="1" style="margin-left: auto; margin-right: auto;"> <tr> <td></td> <td>32"</td> <td>28"</td> </tr> <tr> <td>VOLTAGE (W-B)</td> <td>+5V</td> <td>+6V</td> </tr> </table>		32"	28"	VOLTAGE (W-B)	+5V	+6V
	32"	28"								
VOLTAGE (W-B)	+5V	+6V								
				(NTSC 4.43COLOUR) 1. When NTSC 3.58 COLOUR set, NTSC 4.43 COLOUR will automatically set.						

Item	Measuring instrument	Test point	Adjustment part	Description
SUB HUE I adjustment	Remote control unit		8.HUE	[Method of adjustment without measuring instrument]
			NTSC 3.58 HUE	[NTSC 3.58 HUE] 1. Input a NTSC 3.58MHz COMPOSITE VIDEO signal (full field colour bar with 75% white) from the EXT terminal. 2. Select 2.V/C from the SERVICE MENU. 3. Select 8. HUE with the FUNCTION UP/DOWN (▲/▼) key. 4. Set the initial setting value of NTSC 3.58 HUE with the FUNCTION -/+ (◀/▶) key. 5. If you cannot get the best hue with the initial setting value, make fine adjustment until you get the best hue. 6. Press the MENU key and memorize the set value.
			NTSC 4.43 HUE	(NTSC 4.43 HUE) 1. When NTSC 3.58 is set, NTSC 4.43 will be automatically set at the respective values.
Adjustment of SUB HUE II	Signal generator	TP-47B TP-E(…) [CRT SOCKET PWB]	8. HUE	[Method of adjustment using measuring instrument]
	Oscilloscope		NTSC 3.58 HUE	[NTSC 3.58 HUE] 1. Input a NTSC 3.58MHz COMPOSITE VIDEO signal (full field colour bar with 75% white) from the EXT terminal. 2. Select 2.V/C from the SERVICE MENU. 3. Select 8. HUE with the FUNCTION UP/DOWN (▲/▼) key. 4. Set the initial setting value of NTSC 3.58 HUE with the FUNCTION - or + (◀/▶) key. 5. Connect the oscilloscope between TP-47B and TP-E(…) 6. Adjust NTSC 3.58 HUE to bring the value of (B) in the illustration to the values as shown given below (voltage difference between white (W) and magenta (Mg)). 7. Press the MENU key and memorize the setting value.
	Remote control unit			

	32"	28"
VOLTAGE (W-Mg)	-8V	-3V

		NTSC 4.43 HUE		(NTSC 4.43 HUE) 1. When NTSC 3.58 COLOUR set, NTSC 4.43 COLOUR will automatically set.

DEFLECTION CIRCUIT ADJUSTMENT

There are 4 aspect modes (①FULL, ②PANORAMIC, ③SUBTITLE, ④COMPRES) of the adjustment (1) 100Hz i mode, (2) 120Hz i mode depending upon the kind of signals (vertical frequency 100Hz / 120Hz).

- When the 100Hz FULL mode has been established, the setting of other modes will be done automatically. However, if the picture quality has not been optimized, adjust each mode again, respectively.
- The adjustment using the remote control unit is made on the basis of the initial setting values.
- The setting values which adjust the screen to the optimum condition can be different from the initial setting values.

Initial setting value (AV-32Z25EUY)

* : Fixed value

Setting item	Adjustment name	Initial setting value							
		FULL		PANORAMIC		SUBTITLE		COMPRESS	
		100Hzi	120Hzi	100Hzi	120Hzi	100Hzi	120Hzi	100Hzi	120Hzi
1. V-SHIFT	Vertical center	-002	+008	0000	0000	+006	0000	0000	0000
2. V-SIZE	Vertical height	0000	+002	0000	0000	+001	0000	-014	0000
3. H-CENT	Horizontal center	-012	+004	-002	0000	0000	0000	0000	0000
4. H-SIZE	Horizontal width	-028	-004	-002	0000	0000	0000	-003	0000
5. TRAPEZ	Trapezoidal distortion correction	-012	+007	-003	-002	-002	0000	+002	0000
6. EW-PIN	Side pin correction	-041	+001	0000	-001	0000	-002	0000	0000
7. COR-PIN	Corner Pin	0000	+006	0000	0000	0000	+002	0000	0000
8. COR-UP	Corner Pin correction Up side	0000	+003	0000	0000	0000	0000	0000	0000
9. COR-LO	Corner Pin correction Low side	-005	-013	-004	+002	-005	+003	0000	0000
10. ANGLE	Angle correction	+002	0000	+001	0000	+002	0000	0000	0000
11. BOW	Bow-shaped distortion correction	0000	0000	+001	0000	+001	0000	0000	0000
12. V-S.CR (Do not adjust)	Vertical height correction	0000	-008	0000	0000	+007	0000	0000	0000
13. V-LIN (Do not adjust)	Vertical Linearity	-007	+004	0000	0000	-015	0000	0000	0000

Initial setting value (AV-28Z25EUY)

Setting item	Adjustment name	Initial setting value							
		FULL		PANORAMIC		SUBTITLE		COMPRESS	
		100Hzi	120Hzi	100Hzi	120Hzi	100Hzi	120Hzi	100Hzi	120Hzi
1. V-SHIFT	Vertical center	-004	+009	0000	0000	+005	+001	0000	0000
2. V-SIZE	Vertical height	+005	0000	0000	0000	+001	0000	-015	0000
3. H-CENT	Horizontal center	-007	+004	-003	0000	0000	0000	0000	0000
4. H-SIZE	Horizontal width	-015	-004	-002	0000	0000	0000	0000	0000
5. TRAPEZ	Trapezoidal distortion correction	-022	+009	-004	0000	0000	+006	0000	0000
6. EW-PIN	Side pin correction	-042	0000	0000	0000	0000	0000	0000	0000
7. COR-PIN	Corner Pin	0000	+010	0000	0000	0000	0000	0000	0000
8. COR-UP	Corner Pin correction Up side	0000	+001	0000	-002	0000	-008	0000	0000
9. COR-LO	Corner Pin correction Low side	-005	-007	0000	0000	0000	0000	0000	0000
10. ANGLE	Angle correction	0000	0000	0000	0000	0000	0000	0000	0000
11. BOW	Bow-shaped distortion correction	0000	0000	0000	0000	0000	0000	0000	0000
12. V-S.CR (Do not adjust)	Vertical height correction	+002	0000	0000	0000	+010	0000	0000	0000
13. V-LIN (Do not adjust)	Vertical Linearity	-005	0000	0000	0000	-015	0000	0000	0000

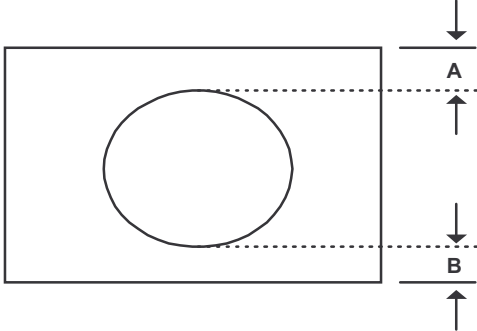
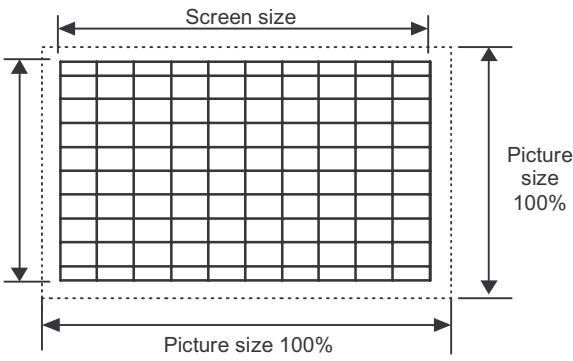
Item	Measuring instrument	Test point	Adjustment part	Description												
V-SHIFT Adjustment	Signal generator Remote control unit		1.V- SHIFT	<p>[FULL mode]</p> <ol style="list-style-type: none"> 1. Receive a circle pattern signal of vertical frequency 50Hz. 2. Select 4.DEF from the SERVICE MENU. 3. Select 1.V-SHIFT with the FUNCTION UP / DOWN (▲/▼) key. 4. Adjust V-SHIFT to make A = B. 5. Check the adjustment value above in other zoom mode. If it is a wrong adjustment, re-adjust in FULL mode and adjust by 1.V-SHIFT. 6. Press the MENU key and memorize the set value. 												
																
V-SIZE adjustment			2.V-SIZE	<ol style="list-style-type: none"> 1. Receive a cross-hatch signal. 2. Select 2.V-SIZE and set the initial setting value. 3. Adjust V-SIZE and make sure that the vertical screen size of the picture size is in the bellow table. 4. Press the MENU key and memorize the set value. 5. Input a NTSC VIDEO signal (60Hz) from the EXT terminal, and make sure that the vertical screen size is in the table below. 6. Press the MENU key and memorize the set value. 												
																
				<table border="1"> <thead> <tr> <th>ASPECT MODE</th> <th>FULL</th> <th>PANORAMIC</th> <th>SUBTITLE</th> </tr> </thead> <tbody> <tr> <td>SCREEN TOP</td> <td>92%</td> <td>87%</td> <td>70%</td> </tr> <tr> <td>SCREEN BOTTOM</td> <td>92%</td> <td>87%</td> <td>83%</td> </tr> </tbody> </table> <p style="text-align: center;">[SCREEN SIZE]</p>	ASPECT MODE	FULL	PANORAMIC	SUBTITLE	SCREEN TOP	92%	87%	70%	SCREEN BOTTOM	92%	87%	83%
ASPECT MODE	FULL	PANORAMIC	SUBTITLE													
SCREEN TOP	92%	87%	70%													
SCREEN BOTTOM	92%	87%	83%													

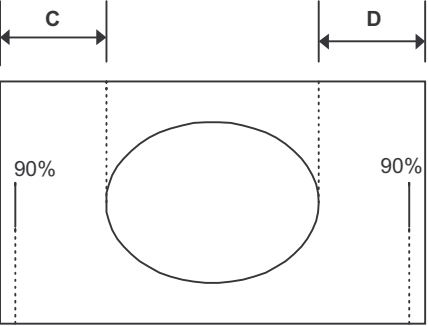
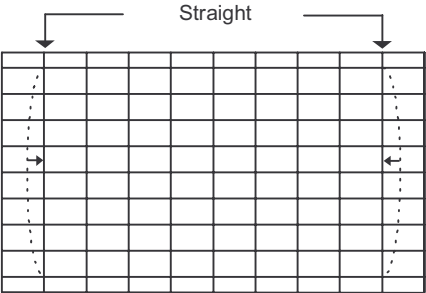
Item	Measuring instrument	Test point	Adjustment part	Description								
H. CENTER adjustment 			3.H-CENT.	<ol style="list-style-type: none"> 1. Receive a circle pattern signal. 2. Select 3.H-CENT and set the initial setting value. 3. Adjust H-CENT to make C=D. 4. Press the MENU key and memorize the set value. 								
H.SIZE adjustment			4.H-SIZE	<ol style="list-style-type: none"> 1. Receive a circle pattern signal. 2. Select 4.H-SIZE and set the initial setting value. 3. Adjust H-SIZE and make sure that the horizontal screen size of the picture size is in the below table. 4. Press the MENU key and memorize the set value. 5. Input a NTSC VIDEO signal (60Hz) from the EXT terminal, and make sure that the horizontal screen size of the each ASPECT mode is in the below table. 6. Press the MENU key and memorize the set value. 								
<table border="1"> <thead> <tr> <th data-bbox="201 1245 426 1308">ASPECT MODE</th> <th data-bbox="426 1245 646 1308">FULL</th> <th data-bbox="646 1245 868 1308">PANORAMIC</th> <th data-bbox="868 1245 1091 1308">SUBTITLE</th> </tr> </thead> <tbody> <tr> <td data-bbox="201 1308 426 1375">H SIZE</td> <td data-bbox="426 1308 646 1375">92%</td> <td data-bbox="646 1308 868 1375">95%</td> <td data-bbox="868 1308 1091 1375">92%</td> </tr> </tbody> </table>					ASPECT MODE	FULL	PANORAMIC	SUBTITLE	H SIZE	92%	95%	92%
ASPECT MODE	FULL	PANORAMIC	SUBTITLE									
H SIZE	92%	95%	92%									
[SCREEN SIZE]												
EW-PIN adjustment			6.EW-PIN	<ol style="list-style-type: none"> 1. Select 6.EW-PIN and set the initial setting value. 2. Adjust EW-PIN and make the 2nd vertical lines at the left and right edges of the screen straight. Also make sure that the 3rd vertical lines are straight. 3. Press the MENU key and memorize the set value. 								
												

Item	Measuring instrument	Test point	Adjustment part	Description
TRAPEZIUM adjustment	Signal generator Remote control unit		5.TRAPEZ	<ol style="list-style-type: none"> 1. Receive a cross-hatch signal. 2. Select 5.TRAPEZ with the FUNCTION UP/DOWN (▲/▼) key. 3. Set the initial setting value of TRAPEZ with the FUNCTION +/- (◀/▶) key. 4. Adjust TRAPEZ and bring the VERTICAL lines at the right and left edges of the screen parallel . 5. Press the MENU key and memorize the set value.
COR. UP/LO adjustment	Signal generator Remote control unit		7.COR-PIN 8.COR-UP 9.COR-LO	<ol style="list-style-type: none"> 1. Select 8.COR-UP with the FUNCTION UP/DOWN (▲/▼) key. 2. Set the initial setting value of COR.-UP with the FUNCTION +/- (◀/▶) key. 3. Adjust COR-UP, and bring the straight line at the upper corner. 4. Select 9.COR-LO with the FUNCTION UP/DOWN (▲/▼) key. 5. Set the initial setting value of COR-LO with the FUNCTION +/- (◀/▶) key. 6. Adjust COR-LO, and bring the straight line at the low corner. 7. Press the MENU key and memorize the set value. 8. If the extreme upper & lower corners are a little pin or barrel chose 7.COR-PIN and adjust. 9. Press the MENU key and memorize the set value.
ANGLE adjustment			10. ANGLE	<ul style="list-style-type: none"> ● In case where there is a parallelogrammical distortion of images on the screen. (Fig.A) <ol style="list-style-type: none"> 1. Select 10.ANGLE with the FUNCTION UP/DOWN (▲/▼) key. 2. Adjust ANGEL, and bring the VERTICAL lines straight. 3. Press the MENU key and memorize the set value.

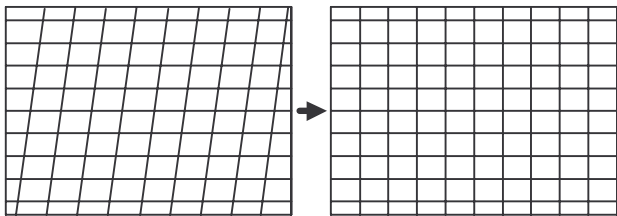
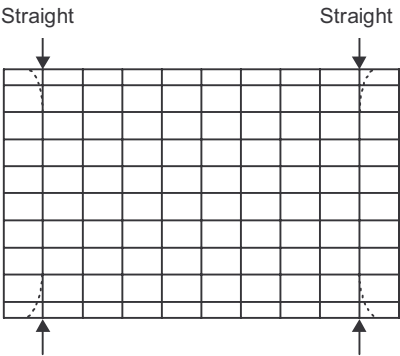
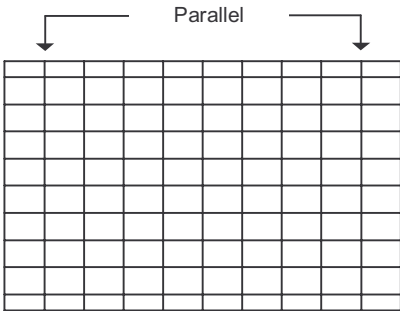
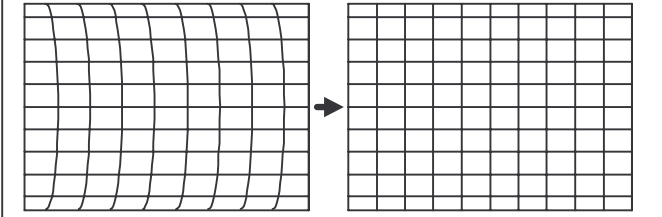
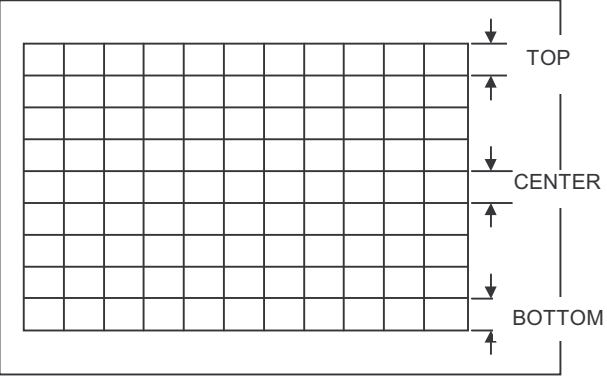

Fig. A

Item	Measuring instrument	Test point	Adjustment part	Description
BOW adjustment			11.BOW	<ul style="list-style-type: none"> ● In case where there is a bow-shaped distortion of images on the screen. (Fig.B) 1. Select 11.BOW with the FUNCTION UP/DOWN (▲/▼) key. 2. Adjust BOW, and bring the VERTICAL lines straight. 3. Press the MENU key and memorize the set value.
				
Fig. B				
V-S.CR & V.LINEARITY adjustment			12.V-S.CR 13.V-LIN	<ul style="list-style-type: none"> ● When the vertical linearity has been deteriorated remarkably, perform the following steps. 1. Receive a cross-hatch signal. 2. Select 13.V-LIN with the FUNCTION UP/DOWN (▲/▼)key. 3. Set the initial setting value of 13.V-LIN with the FUNCTION - / + (◀/▶) key. 4. Select 12.V-S.COR with the FUNCTION UP/DOWN (▲/▼) key. 5. Set the initial setting value of 12.V-S.COR with the FUNCTION - / + (◀/▶) key. 6. Adjust 13.V-LIN and 12.V-S.COR so that the spaces of each line on TOP, CENTER and BOTTOM become uniform. <p>NOTE : Do not adjust PANORAMIC & SUBTITLE mode.</p>
				
				<p>At first the adjustment in 100Hz FULL mode should be done, then the data for the other aspect mode is corrected in the respective value at the same time. And confirm the deflection adjustment initial setting value in 120Hz (NTSC EXT mode) FULL mode. If the adjustment in 100Hz each aspect mode has been done and stored, the data for the same aspect modes in 120Hz is corrected in the respective value. Only the data for the other aspect mode in 120Hz is corrected for itself.</p>

AUDIO CIRCUIT ADJUSTMENT

- Do not touch 3. **AUDIO** adjustment of the SERVICE MENU as it requires no adjustment.
If values had changed for the some reason, set the initial values in the following table.

3. AUDIO (Do not adjust)

Setting item	Variable range	fixed value
1. ERR LIMIT	000H~FF0H	100H
2. A2 ID THR	00H~FFH	19H
3. Q-PEAK	0000H~7FFFH	---

PARTS LIST

CAUTION

- The parts identified by the \triangle symbol are important for the safety. Whenever replacing these parts, be sure to use specified ones to secure the safety.
- The parts not indicated in this Parts List and those which are filled with lines — in the Parts No. columns will not be supplied.
- P. W. Board Ass'y will not be supplied, but those which are filled with the Parts No. in the Parts No. columns will be supplied.

ABBREVIATIONS OF RESISTORS, CAPACITORS AND TOLERANCES

RESISTORS		CAPACITORS	
C R	Carbon Resistor	C CAP.	Ceramic Capacitor
F R	Fusible Resistor	E CAP.	Electrolytic Capacitor
P R	Plate Resistor	M CAP.	Mylar Capacitor
V R	Variable Resistor	HV CAP.	High Voltage Capacitor
HV R	High Voltage Resistor	MF CAP.	Metalized Film Capacitor
MF R	Metal Film Resistor	MM CAP.	Metalized Mylar Capacitor
MG R	Metal Glazed Resistor	MP CAP.	Metalized Polystyrol Capacitor
MP R	Metal Plate Resistor	PP CAP.	Polypropylene Capacitor
OM R	Metal Oxide Film Resistor	PS CAP.	Polystyrol Capacitor
CMF R	Coating Metal Film Resistor	TF CAP.	Thin Film Capacitor
UNF R	Non-Flammable Resistor	MPP CAP.	Metalized Polypropylene Capacitor
CH V R	Chip Variable Resistor	TAN. CAP.	Tantalum Capacitor
CH MG R	Chip Metal Glazed Resistor	CH C CAP.	Chip Ceramic Capacitor
COMP. R	Composition Resistor	BP E CAP.	Bi-Polar Electrolytic Capacitor
LPTC R	Linear Positive Temperature Coefficient Resistor	CH AL E CAP.	Chip Aluminum Electrolytic Capacitor
		CH AL BP CAP.	Chip Aluminum Bi-Polar Capacitor
		CH TAN. E CAP.	Chip Tantalum Electrolytic Capacitor
		CH AL BP E CAP.	Chip Tantalum Bi-Polar Electrolytic Capacitor

TOLERANCES									
F	G	J	K	M	N	R	H	Z	P
±1%	±2%	±5%	±10%	±20%	±30%	+30% -10%	+50% -10%	+80% -20%	+100% -0%

CONTENTS

■ USING PW BOARD & REMOTE CONTROL UNIT	33
■ REMOTE CONTROL UNIT PARTS LIST	33

[AV-32Z25EUY]

■ EXPLODED VIEW PARTS LIST	34
■ EXPLODED VIEW	34,35

[AV-28Z25EUY]

■ EXPLODED VIEW PARTS LIST	36
■ EXPLODED VIEW	36,37

[AV-32Z25EUY]

■ PRINTED WIRING BOARD PARTS LIST	
● MAIN PW BOARD ASS'Y	38
● POWER & DEF. PW BOARD ASS'Y	40
● CRT SOCKET PW BOARD ASS'Y	42
● FRONT CONTROL PW BOARD ASS'Y	43
● SIDE CONTROL PW BOARD ASS'Y	43
● DOLBY PW BOARD ASS'Y	44
● MICOM PW BOARD ASS'Y	47
● AV SW PW BOARD ASS'Y	48
● 100Hz PW BOARD ASS'Y	50

[AV-28Z25EUY]

■ PRINTED WIRING BOARD PARTS LIST	
● MAIN PW BOARD ASS'Y	52
● POWER & DEF. PW BOARD ASS'Y	55
● CRT SOCKET PW BOARD ASS'Y	57
● FRONT CONTROL PW BOARD ASS'Y	58
● SIDE CONTROL PW BOARD ASS'Y	58
● DOLBY PW BOARD ASS'Y	58
● MICOM PW BOARD ASS'Y	58
● AV SW PW BOARD ASS'Y	58
● 100Hz PW BOARD ASS'Y	58

[AV-32Z25EUY] [AV-28Z25EUY]

■ PACKING	59
■ PACKING PARTS LIST	59

USING PW BOARD & REMOTE CONTROL UNIT

PWB ASS'Y \ Model	AV-32Z25EUY	AV-28Z25EUY
MAIN PWB	SMF-1406A	SMF-1405A
POWER & DEF. PWB	SMF-2406A	SMF-2405A
CRT SOCKET PWB	SMF-3406A	SMF-3407A
FRONT CONTROL PWB	SMF-8405A	←
SIDE CONTROL PWB	SMF-8106A	SMF-8105A
DOLBY PWB	SMF-0D401A	←
MICOM PWB	SMF-0M403A	←
AV SW PWB	SMF-0S402A	←
100Hz PWB	SMF-0Z404A	←
REMOTE CONTROL UNIT	RM-C58H-1C	←

REMOTE CONTROL UNIT PARTS LIST

[AV-32Z25EUY] [AV-28Z25EUY] (RM-C58H-1C)

△ Ref. No.	Part No.	Part Name	Description
1	2AA027770	BATTERY COVER	
2	2AA027760	SLIDE COVER	

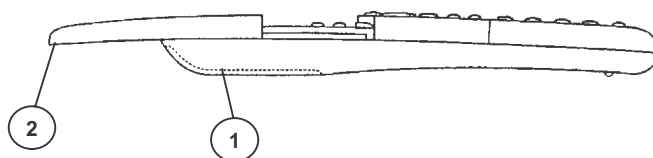

EXPLODED VIEW PARTS LIST

[AV-32Z25EUY]

△ Ref.No.	Part No.	Part Name	Description
1	LC41250-001C-C	JVC MARK	
2	LC31851-001B-C	WINDOW	
△ 100	LC11360-005B-U	FRONT CABI ASSY	Inc. No. 101~103 (SERVICE)
△ 101	LC31201-004A-U	POWER KNOB	
102	AEM3149-001-E	SPRING	
103	LC21031-001C-U	SPEAKER PANEL	
3	QAS0118-001	SPEAKER	SP04
△ 4	LC11308-001B-U	SP BOX T	
△ 5	LC11309-001B-U	SP BOX B	
6	AEM2250-002A-U	BASS INT. DUCT L	(x2)
7	AEM2250-001A-U	BASS INT. DUCT R	(x2)
8	QYSBSAG4016N	TAP SCREW	(x23)
9	LC31935-001A-C	PORT SPACER	(x2)
△ V01	W76ERF042X044	ITC TUBE (C)	Inc. DY, PC MAGNET, WEDGE
△ L01	QQW0066-001	DEGAUSSING COIL	
△ L03	QQW0130-001	ROT-COIL	
△ T2551	QQH0127-001	F. B. TRANSF.	
10	WJY0001-010A	BRAIDED ASSY	
11	WJY0013-002A	BRAIDED SUB ASSY	
12	CHFD125-14BD-N	FFC WIRE	CN-1
△ 13	LC10716-002G-U	CHASSIS BASE	
△ 14	LC11336-002B-U	AV BOARD	
15	QYSBSB3012M	TAPPING SCREW	(x6)
△ 16	LC11311-002A-U	CONTROL BASE	
17	LC31205-001B	CONTROL SHEET	
18	LC10856-001C-U	SIDE CONTROL BASE	
19	QYSBSAG4016N	TAPPING SCREW	
20	QAS0109-001	SPEAKER	SP01-02 (x2)
21	QAS0110-001	SPEAKER	SP03
22	LC11310-001A-U	SPEAKER ADAPTER	(x2)
23	LC40226-003A-H	SPACER	(x4)
24	LC40506-001A	TAPPING SCREW	(x4)
△ 25	QMPK160-185-JC	POWER CORD	CN-PW
△ 26	CM46618-A01-E	POWER CORD CLAMP	
△ 27	LC11316-001B-U	REAR COVER	
28	QYSBSAG4016N	TAPPING SCREW	(x13)
△ 29	LC11548-001A-U	RATING LABEL	
△ 30	LC30789-002B-U	WARNING LABEL	
△ 31	QQR0491-001	CORE FILTER	

EXPLODED VIEW

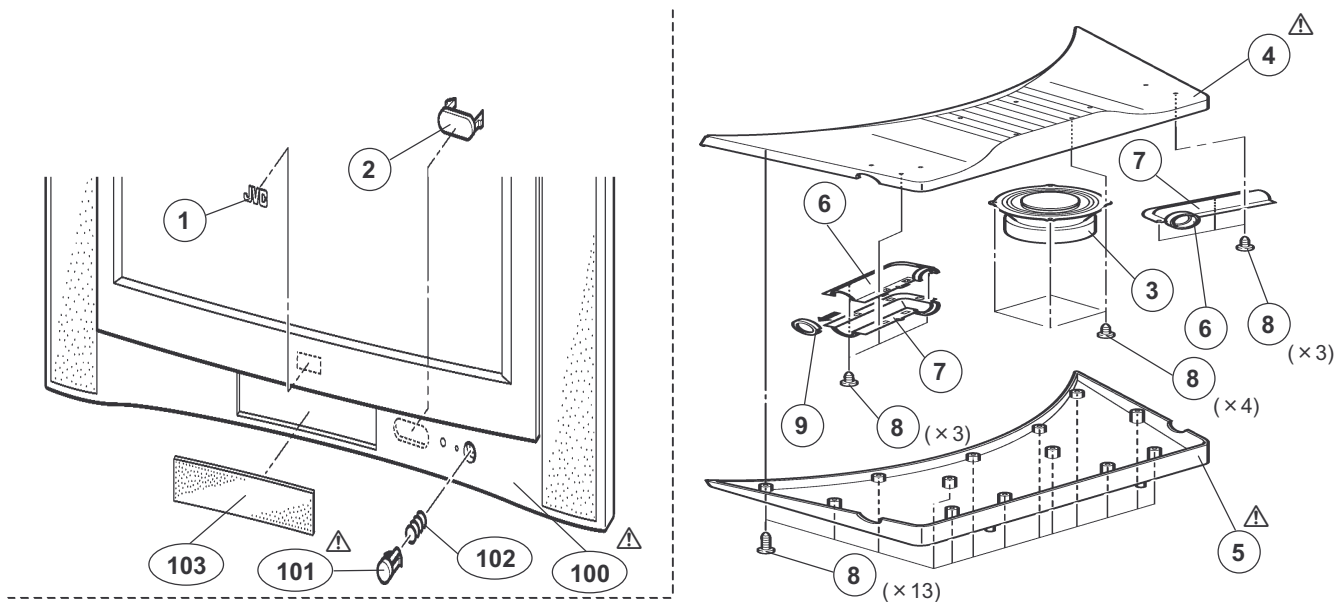

EXPLODED VIEW

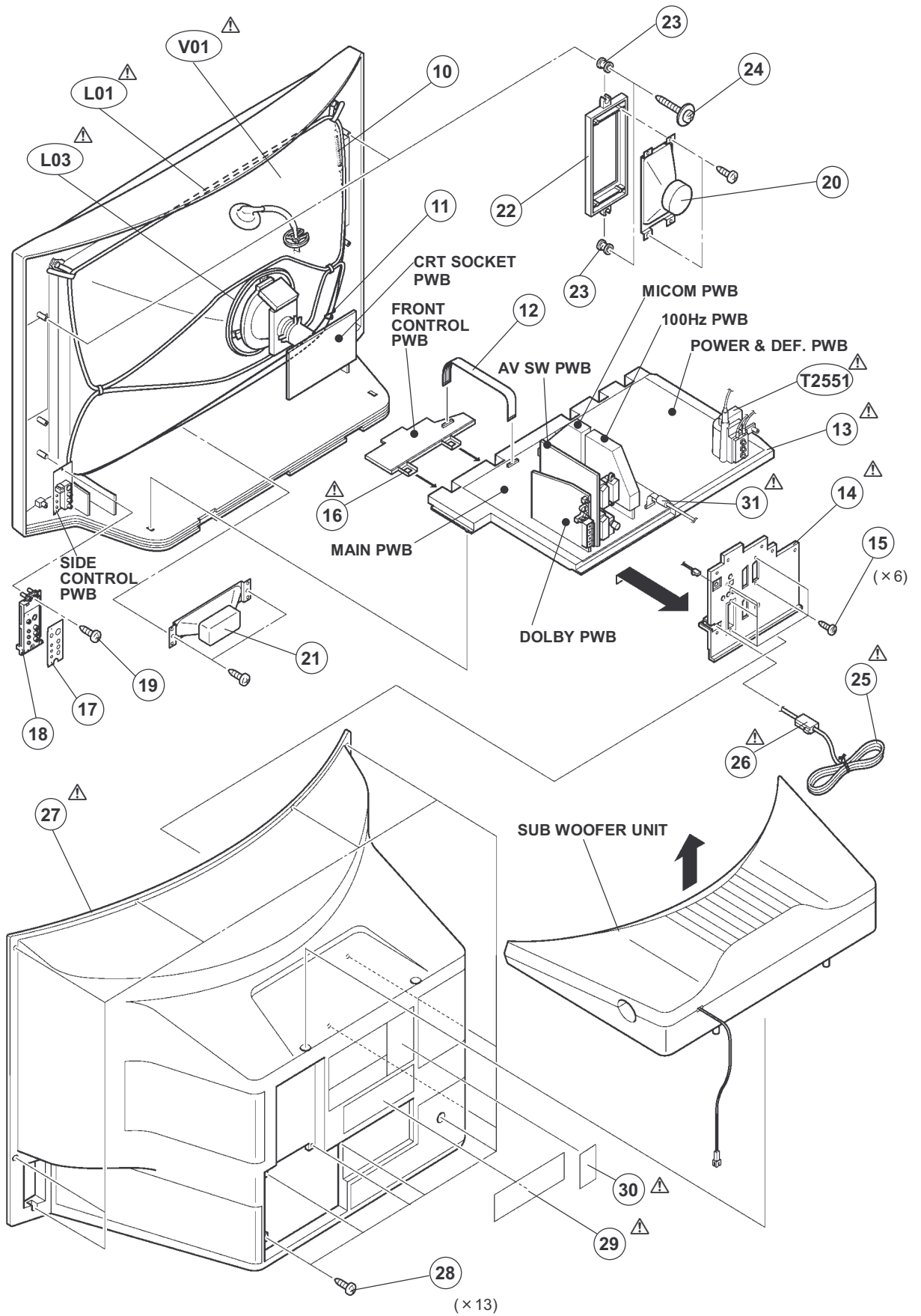

EXPLODED VIEW PARTS LIST

[AV-28Z25EUY]

△ Ref.No.	Part No.	Part Name	Description
1	LC41250-001C-C	JVC MARK	
2	LC31851-001B-C	WINDOW	
△ 100	LC11313-006A-U	FRONT CABI ASSY	Inc. No. 101~103
△ 101	LC31201-004A-U	POWER KNOB	(SERVICE)
102	AEM3149-001-E	SPRING	
103	LC21031-001C-U	SPEAKER PANEL	
3	QAS0118-001	SPEAKER	SP04
△ 4	LC11308-001B-U	SP BOX T	
△ 5	LC11309-001B-U	SP BOX B	
6	AEM2250-002A-U	BASS INT. DUCT L	(x2)
7	AEM2250-001A-U	BASS INT. DUCT R	(x2)
8	QYSBSAG4016N	TAP SCREW	(x23)
9	LC31935-001A-C	PORT SPACER	(x2)
△ V01	W66QDE993X925	ITC TUBE (C)	Inc. DY, PC MAGNET, WEDGE
△ L01	QQW0100-001	DEGAUSSING COIL	
△ T2551	QQH0126-001	F. B. TRANSF.	
10	WJY0001-011A	BRAIDED ASSY	
11	WJY0013-002A	BRAIDED SUB ASSY	
12	CHFD125-11BD-N	FFC WIRE	CN-1
△ 13	LC10716-002G-U	CHASSIS BASE	
△ 14	LC11336-002B-U	AV BOARD	
15	QYSBSB3012M	TAPPING SCREW	(x6)
△ 16	LC11311-001A-U	CONTROL BASE	
17	LC31205-001B	CONTROL SHEET	
18	LC10856-001C-U	SIDE CONTROL BASE	
19	QYSBSAG4016N	TAPPING SCREW	
20	QAS0109-001	SPEAKER	SP01-02 (x2)
21	QAS0110-001	SPEAKER	SP03
22	LC11310-001A-U	SPEAKER ADAPTER	(x2)
23	LC40226-003A-H	SPACER	(x4)
24	LC40506-001A	TAPPING SCREW	(x4)
△ 25	QMPK160-185-JC	POWER CORD	CN-PW
△ 26	CM46618-A01-E	POWER CORD CLAMP	
△ 27	LC11282-001C-U	REAR COVER	
28	QYSBSAG4016N	TAPPING SCREW	(x13)
△ 29	LC11548-002A-U	RATING LABEL	
△ 30	LC30789-002B-U	WARNING LABEL	
△ 31	QQR0491-001	CORE FILTER	

EXPLODED VIEW

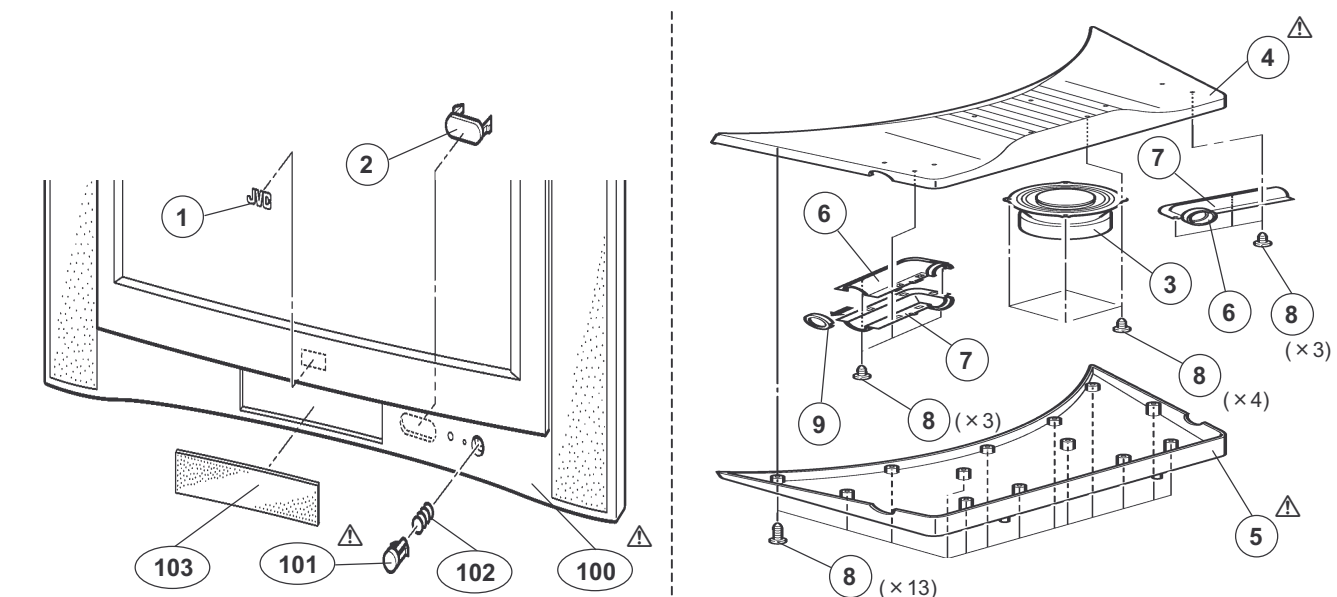

EXPLODED VIEW

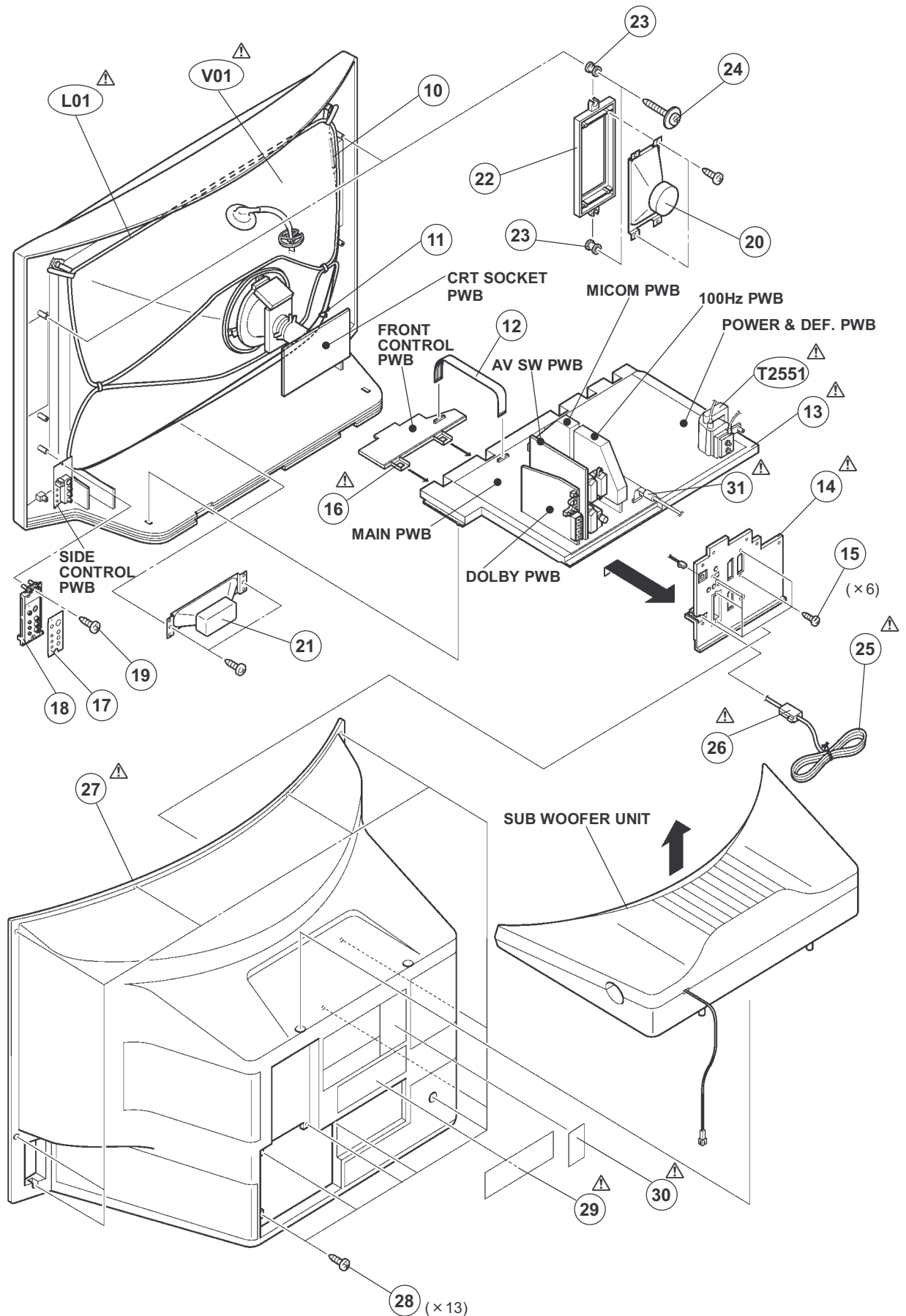

[AV-32Z25EUY]

PRINTED WIRING BOARD PARTS LIST

■ MAIN P.W. BOARD ASS'Y (SMF-1406A)

△ Symbol No.	Part No.	Part Name	Description
RESISTOR			
R1004	NRSA63J-101X	MG R	100Ω 1/16W J
R1005	NRSA63J-101X	MG R	100Ω 1/16W J
R1006	NRSA63J-101X	MG R	100Ω 1/16W J
R1008	NRSA63J-101X	MG R	100Ω 1/16W J
R1009	NRSA63J-0R0X	MG R	0.0Ω 1/16W J
R1302	NRSA63J-0R0X	MG R	0.0Ω 1/16W J
R1103	NRSA63J-222X	MG R	2.2kΩ 1/16W J
R1104	NRSA63J-102X	MG R	1kΩ 1/16W J
R1105	NRSA63J-561X	MG R	560Ω 1/16W J
R1106	NRSA63J-331X	MG R	330Ω 1/16W J
R1108	NRSA63J-102X	MG R	1kΩ 1/16W J
R1109	NRSA63J-101X	MG R	100Ω 1/16W J
R1110	NRSA63J-101X	MG R	100Ω 1/16W J
R1111	NRSA63J-101X	MG R	100Ω 1/16W J
R1151	NRSA63J-101X	MG R	100Ω 1/16W J
R1153	NRSA63J-101X	MG R	100Ω 1/16W J
R1301	NRSA63J-101X	MG R	100Ω 1/16W J
R1302	NRSA63J-101X	MG R	100Ω 1/16W J
R1303	NRSA63J-273X	MG R	27kΩ 1/16W J
R1304	NRSA63J-102X	MG R	1kΩ 1/16W J
R1311	NRSA63J-331X	MG R	330Ω 1/16W J
R1312	NRSA63J-273X	MG R	27kΩ 1/16W J
R1313	NRSA63J-183X	MG R	18kΩ 1/16W J
R1314	NRSA63J-221X	MG R	220Ω 1/16W J
R1315	NRSA63J-101X	MG R	100Ω 1/16W J
R1316	NRSA63J-101X	MG R	100Ω 1/16W J
R1317	NRSA63J-101X	MG R	100Ω 1/16W J
R1318	NRSA63J-562X	MG R	5.6kΩ 1/16W J
R1319	NRSA63J-183X	MG R	18kΩ 1/16W J
R1321	NRSA63J-0R0X	MG R	0.0Ω 1/16W J
R1322	NRSA63J-0R0X	MG R	0.0Ω 1/16W J
R1325	NRSA63J-101X	MG R	100Ω 1/16W J
R1326	NRSA63J-682X	MG R	6.8kΩ 1/16W J
R1401	NRSA63J-102X	MG R	1kΩ 1/16W J
R1402	NRSA63J-102X	MG R	1kΩ 1/16W J
R1403	NRSA63J-331X	MG R	330Ω 1/16W J
R1404	NRSA63J-331X	MG R	330Ω 1/16W J
R1405	NRSA63J-102X	MG R	1kΩ 1/16W J
R1406	NRSA63J-102X	MG R	1kΩ 1/16W J
R1451	NRSA63J-821X	MG R	820Ω 1/16W J
R1454	NRSA63J-472X	MG R	4.7kΩ 1/16W J
R1455	NRSA63J-123X	MG R	12kΩ 1/16W J
R1456	NRSA63J-123X	MG R	12kΩ 1/16W J
R1457	NRSA63J-392X	MG R	3.9kΩ 1/16W J
R1458	NRSA63J-123X	MG R	12kΩ 1/16W J
R1459	NRSA63J-472X	MG R	4.7kΩ 1/16W J
R1461	NRSA63J-123X	MG R	12kΩ 1/16W J
R1462	NRSA63J-153X	MG R	15kΩ 1/16W J
R1463	NRSA63J-124X	MG R	120kΩ 1/16W J
R1464	NRSA63J-563X	MG R	56kΩ 1/16W J
R1465	NRSA63J-224X	MG R	220kΩ 1/16W J
R1466	NRSA63J-224X	MG R	220kΩ 1/16W J
R1467	NRSA63J-563X	MG R	56kΩ 1/16W J
R1468	NRSA63J-224X	MG R	220kΩ 1/16W J
R1469	NRSA63J-683X	MG R	68kΩ 1/16W J
R1470	NRSA63J-223X	MG R	22kΩ 1/16W J
R1471	NRSA63J-273X	MG R	27kΩ 1/16W J
R1472	NRSA63J-682X	MG R	6.8kΩ 1/16W J
R1473	NRSA63J-123X	MG R	12kΩ 1/16W J
R1474	NRSA63J-563X	MG R	56kΩ 1/16W J
R1475	NRSA63J-153X	MG R	15kΩ 1/16W J
R1476	NRSA63J-123X	MG R	12kΩ 1/16W J
R1477	NRSA63J-123X	MG R	12kΩ 1/16W J
R1478	NRSA63J-123X	MG R	12kΩ 1/16W J
R1479	NRSA63J-154X	MG R	150kΩ 1/16W J
R1480	NRSA63J-823X	MG R	82kΩ 1/16W J
R1481	NRSA63J-472X	MG R	4.7kΩ 1/16W J
R1482	NRSA63J-272X	MG R	2.7kΩ 1/16W J
R1483	NRSA63J-472X	MG R	4.7kΩ 1/16W J
R1484	NRSA63J-473X	MG R	47kΩ 1/16W J
R1485	NRSA63J-123X	MG R	12kΩ 1/16W J
R1486	NRSA63J-472X	MG R	4.7kΩ 1/16W J
R1487	NRSA63J-333X	MG R	33kΩ 1/16W J
R1489	NRSA63J-333X	MG R	33kΩ 1/16W J

△ Symbol No.	Part No.	Part Name	Description
RESISTOR			
R1491	NRSA63J-472X	MG R	4.7kΩ 1/16W J
R1492	NRSA63J-562X	MG R	5.6kΩ 1/16W J
R1493	NRSA63J-183X	MG R	18kΩ 1/16W J
R1501	NRSA63J-0R0X	MG R	0.0Ω 1/16W J
R1504	NRSA63J-102X	MG R	1kΩ 1/16W J
R1511	NRSA63J-152X	MG R	1.5kΩ 1/16W J
R1512	NRSA63J-332X	MG R	3.3kΩ 1/16W J
R1521	NRSA63J-223X	MG R	22kΩ 1/16W J
R1522	NRSA63J-562X	MG R	5.6kΩ 1/16W J
R1551	NRSA63J-100X	MG R	10Ω 1/16W J
R1552	NRSA63J-124X	MG R	120kΩ 1/16W J
R1553	NRSA63J-683X	MG R	68kΩ 1/16W J
R1554	NRSA63J-562X	MG R	5.6kΩ 1/16W J
R1555	NRSA63J-333X	MG R	33kΩ 1/16W J
R1556	NRSA63J-472X	MG R	4.7kΩ 1/16W J
R1557	NRSA63J-562X	MG R	5.6kΩ 1/16W J
R1558	NRSA63J-104X	MG R	100kΩ 1/16W J
R1559	NRSA63J-154X	MG R	150kΩ 1/16W J
R1560	NRSA63J-100X	MG R	10Ω 1/16W J
R1561	QRM143J-0R0X	C R	0.0Ω 1/4W J
R1562	NRSA63J-683X	MG R	68kΩ 1/16W J
R1563	NRSA63J-103X	MG R	10kΩ 1/16W J
R1564	NRSA63J-223X	MG R	22kΩ 1/16W J
R1565	NRSA63J-562X	MG R	5.6kΩ 1/16W J
R1591	NRSA63J-561X	MG R	560Ω 1/16W J
R1592	NRSA63J-332X	MG R	3.3kΩ 1/16W J
R1595	NRSA63J-222X	MG R	2.2kΩ 1/16W J
R1596	NRSA63J-104X	MG R	100kΩ 1/16W J
R1601	NRSA63J-472X	MG R	4.7kΩ 1/16W J
R1603	NRSA63J-472X	MG R	4.7kΩ 1/16W J
R1604	NRSA63J-104X	MG R	100kΩ 1/16W J
R1605	NRSA63J-472X	MG R	4.7kΩ 1/16W J
R1607	NRSA63J-103X	MG R	10kΩ 1/16W J
R1608	NRSA63J-103X	MG R	10kΩ 1/16W J
R1609	NRSA63J-103X	MG R	10kΩ 1/16W J
R1613	NRSA63J-223X	MG R	22kΩ 1/16W J
R1614	NRSA63J-104X	MG R	100kΩ 1/16W J
R1616	NRSA63J-822X	MG R	8.2kΩ 1/16W J
R1617	NRSA63J-103X	MG R	10kΩ 1/16W J
R1618	NRSA63J-822X	MG R	8.2kΩ 1/16W J
R1619	NRSA63J-473X	MG R	47kΩ 1/16W J
R1622	NRSA63J-822X	MG R	8.2kΩ 1/16W J
R1623	NRSA63J-103X	MG R	10kΩ 1/16W J
R1624	NRSA63J-473X	MG R	47kΩ 1/16W J
R1625	NRSA63J-472X	MG R	4.7kΩ 1/16W J
R1626	NRSA63J-104X	MG R	100kΩ 1/16W J
R1627	NRSA63J-472X	MG R	4.7kΩ 1/16W J
R1628	NRSA63J-104X	MG R	100kΩ 1/16W J
R1629	NRSA63J-472X	MG R	4.7kΩ 1/16W J
R1630	NRSA63J-104X	MG R	100kΩ 1/16W J
R1631	NRSA63J-103X	MG R	10kΩ 1/16W J
R1632	NRSA63J-103X	MG R	10kΩ 1/16W J
R1633	NRSA63J-103X	MG R	10kΩ 1/16W J
R1637	NRSA63J-822X	MG R	8.2kΩ 1/16W J
R1638	NRSA63J-103X	MG R	10kΩ 1/16W J
R1639	NRSA63J-473X	MG R	47kΩ 1/16W J
R1640	NRSA63J-822X	MG R	8.2kΩ 1/16W J
R1641	NRSA63J-103X	MG R	10kΩ 1/16W J
R1642	NRSA63J-473X	MG R	47kΩ 1/16W J
R1643	NRSA63J-822X	MG R	8.2kΩ 1/16W J
R1646	NRSA63J-822X	MG R	8.2kΩ 1/16W J
R1649	NRSA63J-223X	MG R	22kΩ 1/16W J
R1650	NRSA63J-223X	MG R	22kΩ 1/16W J
R1651	NRSA63J-223X	MG R	22kΩ 1/16W J
R1652	NRSA63J-473X	MG R	47kΩ 1/16W J
R1653	NRSA63J-273X	MG R	27kΩ 1/16W J
R1655	NRSA63J-104X	MG R	100kΩ 1/16W J
R1656	NRSA63J-822X	MG R	8.2kΩ 1/16W J
R1657	NRSA63J-104X	MG R	100kΩ 1/16W J
R1701	NRSA63J-103X	MG R	10kΩ 1/16W J
R1702	NRSA63J-103X	MG R	10kΩ 1/16W J
R1703	NRSA63J-102X	MG R	1kΩ 1/16W J
R1704	NRSA63J-102X	MG R	1kΩ 1/16W J
R1706	NRSA63J-103X	MG R	10kΩ 1/16W J

Symbol No.	Part No.	Part Name	Description
RESISTOR			
R1707	NRSA63J-103X	MG R	10kΩ 1/16W J
R1708	NRSA63J-103X	MG R	10kΩ 1/16W J
R1709	QRE121J-151Y	C R	150Ω 1/2W J
R1711	NRSA63J-101X	MG R	100Ω 1/16W J
R1712	NRSA63J-101X	MG R	100Ω 1/16W J
R1714	NRSA63J-102X	MG R	1kΩ 1/16W J
R1715	NRSA63J-102X	MG R	1kΩ 1/16W J
R1720	NRSA63J-102X	MG R	1kΩ 1/16W J
R1721	NRSA63J-102X	MG R	1kΩ 1/16W J
R1722	NRSA63J-102X	MG R	1kΩ 1/16W J
R1772	NRSA63J-221X	MG R	220Ω 1/16W J
R1773	NRSA63J-221X	MG R	220Ω 1/16W J
R1774	NRSA63J-221X	MG R	220Ω 1/16W J
R1775	NRSA63J-221X	MG R	220Ω 1/16W J
R1776	NRSA63J-221X	MG R	220Ω 1/16W J
R1951	QRK126J-220X	C R	22Ω 1/2W J

Symbol No.	Part No.	Part Name	Description
CAPACITOR			
C1001	NCB31HK-222X	C CAP.	2200pF 50V K
C1002	QETN1HM-106Z	E CAP.	10μF 50V M
C1004	NCB31CK-104X	C CAP.	0.1μF 16V K
C1005	QETN1CM-108Z	E CAP.	1000μF 16V M
C1006	NCB31HK-103X	C CAP.	0.01μF 50V K
C1007	QETN1HM-106Z	E CAP.	10μF 50V M
C1009	NCB31CK-104X	C CAP.	0.1μF 16V K
C1010	QETN1HM-106Z	E CAP.	10μF 50V M
C1101	NCB31CK-104X	C CAP.	0.1μF 16V K
C1102	QETN1HM-106Z	E CAP.	10μF 50V M
C1103	NCB31CK-104X	C CAP.	0.1μF 16V K
C1104	QETN1CM-107Z	E CAP.	1000μF 16V M
C1105	QETN1HM-106Z	E CAP.	10μF 50V M
C1106	NCB31CK-104X	C CAP.	0.1μF 16V K
C1107	NCB31CK-104X	C CAP.	0.1μF 16V K
C1111	NCB31HK-103X	C CAP.	0.01μF 50V K
C1116	NCB31HK-472X	C CAP.	4700pF 50V K
C1117	NCB31HK-103X	C CAP.	0.01μF 50V K
C1118	NCB31HK-103X	C CAP.	0.01μF 50V K
C1119	NDC31HJ-2R0X	C CAP.	2.0pF 50V J
C1120	NDC31HJ-2R0X	C CAP.	2.0pF 50V J
C1121	NCB31HK-103X	C CAP.	0.01μF 50V K
C1122	NDC31HJ-102X	C CAP.	1000pF 50V J
C1123	NDC31HJ-102X	C CAP.	1000pF 50V J
C1124	QETN1HM-106Z	E CAP.	10μF 50V M
C1125	QETN1HM-106Z	E CAP.	10μF 50V M
C1126	NCB31CK-104X	C CAP.	0.1μF 16V K
C1127	QETN1HM-106Z	E CAP.	10μF 50V M
C1128	NCB31CK-104X	C CAP.	0.1μF 16V K
C1129	NCF31AZ-105X	C CAP.	1μF 10V Z
C1130	QETN1HM-106Z	E CAP.	10μF 50V M
C1151	NCF31AZ-105X	C CAP.	1μF 10V Z
C1152	NCF31AZ-105X	C CAP.	1μF 10V Z
C1301	QETN1CM-107Z	E CAP.	1000μF 16V M
C1302	NCB31CK-104X	C CAP.	0.1μF 16V K
C1303	NCB31CK-104X	C CAP.	0.1μF 16V K
C1305	NCB31CK-104X	C CAP.	0.1μF 16V K
C1306	NCB31CK-104X	C CAP.	0.1μF 16V K
C1307	NCB31CK-104X	C CAP.	0.1μF 16V K
C1308	NCB31CK-104X	C CAP.	0.1μF 16V K
C1309	NCB31CK-104X	C CAP.	0.1μF 16V K
C1310	QETN1AM-228Z	E CAP.	2200μF 10V M
C1311	NCB31CK-683X	C CAP.	0.068μF 16V K
C1312	NDC31HJ-221X	C CAP.	220pF 50V J
C1313	NCB31HK-223X	C CAP.	0.022μF 50V K
C1314	NCB31HK-223X	C CAP.	0.022μF 50V K
C1315	NCB31HK-223X	C CAP.	0.022μF 50V K
C1316	NCB31HK-103X	C CAP.	0.01μF 50V K
C1317	NCB31HK-103X	C CAP.	0.01μF 50V K
C1318	NCB31HK-103X	C CAP.	0.01μF 50V K
C1320	QETN0JM-228Z	E CAP.	2200μF 6.3V M
C1321	NCB31HK-223X	C CAP.	0.022μF 50V K
C1322	NCB31HK-223X	C CAP.	0.022μF 50V K
C1323	NCB31HK-223X	C CAP.	0.022μF 50V K
C1324	NDC31HJ-820X	C CAP.	82pF 50V J
C1351	QENC1EM-106Z	BP E CAP.	10μF 25V M
C1401	NCB31CK-104X	C CAP.	0.1μF 16V K
C1402	QETN1CM-107Z	E CAP.	1000μF 16V M
C1403	NCB31CK-104X	C CAP.	0.1μF 16V K
C1404	NCB31CK-104X	C CAP.	0.1μF 16V K
C1453	NCB31HK-103X	C CAP.	0.01μF 50V K

Symbol No.	Part No.	Part Name	Description
CAPACITOR			
C1454	NCB31EK-333X	C CAP.	0.033μF 25V K
C1455	NCB31CK-104X	C CAP.	0.1μF 16V K
C1456	NCB31CK-104X	C CAP.	0.1μF 16V K
C1457	NCB31EK-333X	C CAP.	0.033μF 25V K
C1458	NCB31CK-104X	C CAP.	0.1μF 16V K
C1491	NCB31EK-473X	C CAP.	0.047μF 25V K
C1471	NCB31CK-104X	C CAP.	0.1μF 16V K
C1472	NCB31HK-103X	C CAP.	0.01μF 50V K
C1473	NCB31CK-104X	C CAP.	0.1μF 16V K
C1474	NCB31EK-333X	C CAP.	0.033μF 25V K
C1475	NCB31CK-104X	C CAP.	0.1μF 16V K
C1501	NDC31HJ-150X	C CAP.	15pF 50V J
C1502	NDC31HJ-150X	C CAP.	15pF 50V J
C1551	NCF31CZ-224X	C CAP.	0.22μF 16V Z
C1552	NCF31CZ-224X	C CAP.	0.22μF 16V Z
C1553	QETN1EM-476Z	E CAP.	47μF 25V M
C1554	NCF31CZ-224X	C CAP.	0.22μF 16V Z
C1555	NCF31CZ-224X	C CAP.	0.22μF 16V Z
C1560	QETN1CM-107Z	E CAP.	1000μF 16V M
C1561	NDC31HJ-561X	C CAP.	560pF 50V J
C1562	QETN1HM-105Z	E CAP.	1μF 50V M
C1564	NCB31CK-104X	C CAP.	0.1μF 16V K
C1591	NDC31HJ-471X	C CAP.	470pF 50V J
C1596	NCB31CK-104X	C CAP.	0.1μF 16V K
C1601	QETN1HM-106Z	E CAP.	10μF 50V M
C1602	QETN1HM-106Z	E CAP.	10μF 50V M
C1603	QETN1HM-106Z	E CAP.	10μF 50V M
C1604	QETN1HM-107Z	E CAP.	1000μF 50V M
C1611	QETN1EM-108Z	E CAP.	1000μF 25V M
C1612	QETN1EM-108Z	E CAP.	1000μF 25V M
C1613	QETN1EM-108Z	E CAP.	1000μF 25V M
C1614	QETN1HM-106Z	E CAP.	10μF 50V M
C1616	QETN1HM-106Z	E CAP.	10μF 50V M
C1617	QETN1HM-106Z	E CAP.	10μF 50V M
C1618	QETN1HM-106Z	E CAP.	10μF 50V M
C1619	QETN1HM-106Z	E CAP.	10μF 50V M
C1620	QETN1HM-107Z	E CAP.	1000μF 50V M
C1621	QETN1VM-228	E CAP.	2200μF 35V M
C1628	QETN1EM-108Z	E CAP.	1000μF 25V M
C1629	QETN1EM-338	E CAP.	3300μF 25V M
C1630	QETN1EM-108Z	E CAP.	1000μF 25V M
C1631	QETN1HM-106Z	E CAP.	10μF 50V M
C1633	QETN1HM-106Z	E CAP.	10μF 50V M
C1634	QETN1CM-108Z	E CAP.	1000μF 16V M
C1635	QETN1VM-228	E CAP.	2200μF 35V M
C1636	QETN1HM-107Z	E CAP.	1000μF 50V M
C1637	QETN1HM-107Z	E CAP.	1000μF 50V M
C1638	NCB31HK-104X	C CAP.	0.1μF 50V K
C1639	QETN1CM-108Z	E CAP.	1000μF 16V M
C1640	QETN1CM-107Z	E CAP.	1000μF 16V M
C1641	QETN1CM-107Z	E CAP.	1000μF 16V M
C1642	NCB31HK-104X	C CAP.	0.1μF 50V K
C1701	QETN1HM-106Z	E CAP.	10μF 50V M
C1702	NCB31CK-563X	C CAP.	0.056μF 16V K
C1703	QETN1CM-107Z	E CAP.	1000μF 16V M
C1951	QETN1CM-477Z	E CAP.	4700μF 16V M
C1952	NCB31CK-104X	C CAP.	0.1μF 16V K
C1953	NCB31CK-104X	C CAP.	0.1μF 16V K
C1954	QETN1AM-477Z	E CAP.	470μF 10V M
C1955	QETN1AM-227Z	E CAP.	220μF 10V M
C1956	QETN1AM-107Z	E CAP.	100μF 10V M

Symbol No.	Part No.	Part Name	Description
COIL			
L1001	QQL244K-270Z	COIL	27μH K
L1002	QQL244K-100Z	COIL	10μH K
L1003	QQL244K-100Z	COIL	10μH K
L1101	QRN143J-0R0X	C R	0.0Ω 1/4W J
L1102	QQL244K-4R7Z	COIL	4.7μH K
L1301	NQL092K-1R5X	COIL	1.5μH
L1302	NQL092K-1R5X	COIL	1.5μH
L1951	QQL26AM-5R6Z	COIL	5.6μH M

Symbol No.	Part No.	Part Name	Description
DIODE			
D1317	MA111-X	SI. DIODE	
D1318	MA111-X	SI. DIODE	
D1319	MA3036-X	ZENER DIODE	
D1320	MA3056/M/-X	ZENER DIODE	
D1321	MA3056/M/-X	ZENER DIODE	

△ Symbol No.	Part No.	Part Name	Description
DIODE			
D1471	MA111-X	SI. DIODE	
D1472	MA111-X	SI. DIODE	
D1473	MA111-X	SI. DIODE	
D1474	MA111-X	SI. DIODE	
D1475	MA3240/M/-X	ZENER DIODE	
D1521	MA111-X	SI. DIODE	
D1591	MA111-X	SI. DIODE	
D1592	MA3051/M/-X	ZENER DIODE	
D1593	MA111-X	SI. DIODE	
D1601	MA3330/L/-X	ZENER DIODE	
D1602	MA3330/L/-X	ZENER DIODE	
D1603	MA3330/L/-X	ZENER DIODE	
D1604	MA111-X	SI. DIODE	
D1606	MA111-X	SI. DIODE	
D1607	MA111-X	SI. DIODE	
D1608	MA111-X	SI. DIODE	
D1610	MA111-X	SI. DIODE	
D1611	MA3330/L/-X	ZENER DIODE	
D1612	MA3330/L/-X	ZENER DIODE	
D1613	MA3330/L/-X	ZENER DIODE	
D1614	MA111-X	SI. DIODE	
D1615	MA111-X	SI. DIODE	
D1616	MA111-X	SI. DIODE	
D1617	MA111-X	SI. DIODE	
D1618	MA111-X	SI. DIODE	
D1619	MA111-X	SI. DIODE	
D1620	MA111-X	SI. DIODE	
D1621	MA111-X	SI. DIODE	
D1622	MA111-X	SI. DIODE	
D1623	MA111-X	SI. DIODE	
D1624	MA111-X	SI. DIODE	
D1771	MA3056/M/-X	ZENER DIODE	
D1772	MA3056/M/-X	ZENER DIODE	
D1773	MA3056/M/-X	ZENER DIODE	
D1774	MA3056/M/-X	ZENER DIODE	
D1775	MA3033-X	ZENER DIODE	
D1951	1SR35-400A-T2	SI. DIODE	
D1981	MA111-X	SI. DIODE	
D1982	MA111-X	SI. DIODE	

TRANSISTOR

Q1101	2SC2412K/QR/-X	SI. TRANSISTOR	
Q1102	2SC2412K/QR/-X	SI. TRANSISTOR	
Q1301	2SA1037AK/QR/-X	SI. TRANSISTOR	
Q1471	2SC2412K/QR/-X	SI. TRANSISTOR	
Q1472	2SC2412K/QR/-X	SI. TRANSISTOR	
Q1561	2SC2412K/QR/-X	SI. TRANSISTOR	
Q1562	2SA1037AK/QR/-X	SI. TRANSISTOR	
Q1591	2SA1037AK/QR/-X	SI. TRANSISTOR	
Q1592	2SC2412K/QR/-X	SI. TRANSISTOR	
Q1601	2SA1037AK/QR/-X	SI. TRANSISTOR	
Q1603	DTC144EKA-X	DIGI. TRANSISTOR	
Q1605	DTC144EKA-X	DIGI. TRANSISTOR	
Q1606	2SC2412K/QR/-X	SI. TRANSISTOR	
Q1608	DTC144EKA-X	DIGI. TRANSISTOR	
Q1609	2SC2412K/QR/-X	SI. TRANSISTOR	
Q1611	2SA1037AK/QR/-X	SI. TRANSISTOR	
Q1612	DTC144EKA-X	DIGI. TRANSISTOR	
Q1613	DTC144EKA-X	DIGI. TRANSISTOR	
Q1614	DTC144EKA-X	DIGI. TRANSISTOR	
Q1615	DTC144EKA-X	DIGI. TRANSISTOR	
Q1616	2SC2412K/QR/-X	SI. TRANSISTOR	
Q1617	DTC144EKA-X	DIGI. TRANSISTOR	
Q1618	2SC2412K/QR/-X	SI. TRANSISTOR	
Q1620	2SA1037AK/QR/-X	SI. TRANSISTOR	

IC

IC1101	MSP3415DQGB3GHX	IC	
IC1301	SDA9380	IC	
IC1402	BA10324AF-XE	IC	
IC1471	BA10358F-XE	IC	
IC1551	LA6515	I C	
IC1601	AN7585	IC	
IC1602	AN7585	IC	
IC1603	AN78L24-T	IC	
IC1604	AN78L05-T	IC	
IC1701	JLC1562BF-X	I C	
IC1951	BA09T	IC	
IC1952	BA08T	IC	

OTHERS

CN1002	QGF1220C2-25	FFC/FPC CONNE	
K1001	NQR0389-003X	FERRITE BEADS	

△ Symbol No.	Part No.	Part Name	Description
OTHERS			
K1101	NQR0389-003X	FERRITE BEADS	
K1102	NQR0389-003X	FERRITE BEADS	
K1301	NQR0413-003X	FERRITE BEADS	
LC1102	NQR0431-001X	EMI FILTER	
LC1301	NQR0431-001X	EMI FILTER	
LC1302	NQR0431-001X	EMI FILTER	
LC1303	NQR0431-001X	EMI FILTER	
TU1001	QAU0276-001	TUNER	
X1101	CE42546-001Z	CRYSTAL	
X1501	QAX0549-001Z	CRYSTAL	

POWER & DEF. P.W. BOARD ASS'Y (SMF-2406A)

△ Symbol No.	Part No.	Part Name	Description
RESISTOR			
R2401	QRE141J-562Y	C R	5.6kΩ 1/4W J
R2402	QRE141J-562Y	C R	5.6kΩ 1/4W J
R2403	QRE141J-222Y	C R	2.2kΩ 1/4W J
R2404	QRX01GJ-1R0	MF R	1.0Ω 1W J
R2405	QRL029J-151	OM R	150Ω 2W J
R2406	QRE141J-222Y	C R	2.2kΩ 1/4W J
R2407	QRX01GJ-2R2	MF R	2.2Ω 1W J
R2408	QRX01GJ-1R5	MF R	1.5Ω 1W J
R2409	QRE141J-823Y	C R	82kΩ 1/4W J
R2410	QRE141J-103Y	C R	10kΩ 1/4W J
R2421	QRE141J-103Y	C R	10kΩ 1/4W J
R2422	QRE141J-274Y	C R	270kΩ 1/4W J
R2461	QRG029J-820	OM R	82Ω 2W J
R2462	QRE141J-473Y	C R	47kΩ 1/4W J
R2463	QRE141J-682Y	C R	6.8kΩ 1/4W J
R2464	QRX01GJ-3R3	MF R	3.3Ω 1W J
R2468	QRE141J-102Y	C R	1kΩ 1/4W J
R2469	QRE141J-272Y	C R	2.7kΩ 1/4W J
R2471	QRE141J-391Y	C R	390Ω 1/4W J
R2472	QRA14CF-1002Y	MF R	10kΩ 1/4W F
R2473	QRE141J-473Y	C R	47kΩ 1/4W J
R2474	QRE141J-103Y	C R	10kΩ 1/4W J
R2475	QRE141J-102Y	C R	1kΩ 1/4W J
R2476	QRE141J-102Y	C R	1kΩ 1/4W J
R2477	QRE141J-563Y	C R	56kΩ 1/4W J
R2478	QRE141J-333Y	C R	33kΩ 1/4W J
R2501	QRE141J-471Y	C R	470Ω 1/4W J
R2502	QRE141J-123Y	C R	12kΩ 1/4W J
R2503	QRE121J-152Y	C R	1.5kΩ 1/2W J
R2504	QRL039J-272	OM R	2.7kΩ 3W J
R2505	QRL039J-272	OM R	2.7kΩ 3W J
R2506	QRE121J-5R6Y	C R	5.6Ω 1/2W J
R2521	QRE121J-471Y	C R	470Ω 1/2W J
R2522	QRE141J-223Y	C R	22kΩ 1/4W J
R2523	QRE141J-103Y	C R	10kΩ 1/4W J
R2524	QRC121K-152Z	COMP. R	1.5kΩ 1/2W K
R2525	QRL039J-103	OM R	10kΩ 3W J
R2541	QRE141J-182Y	C R	1.8kΩ 1/4W J
R2542	QRE141J-222Y	C R	2.2kΩ 1/4W J
R2543	QRE121J-272Y	C R	2.7kΩ 1/2W J
△ R2551	QRZ9022-R47	F R	0.47 Ω 1W K
△ R2552	QRZ9022-R47	F R	0.47 Ω 1W K
△ R2555	QRZ9022-R33	F R	0.33 Ω 1W K
R2561	QRG01GJ-220	OM R	22Ω 1W J
R2562	QRE121J-123Y	C R	12kΩ 1/2W J
R2563	QRZ0056-103Z	COMP R	10kΩ 1/2W K
R2581	QRF154K-4R7	UNF R	4.7Ω 15W K
R2582	QRE141J-681Y	C R	680Ω 1/4W J
R2583	QRE121J-682Y	C R	6.8kΩ 1/2W J
R2584	QRE141J-183Y	C R	18kΩ 1/4W J
R2585	QRE141J-222Y	C R	2.2kΩ 1/4W J
R2586	QRA14CF-6201Y	MF R	6.2kΩ 1/4W F
R2587	QRA14CF-2801Y	MF R	2.8kΩ 1/4W F
R2588	QRE141J-103Y	C R	10kΩ 1/4W J

Symbol No.	Part No.	Part Name	Description
RESISTOR			
△ R2591	QRZ9017-487	F R	4.7 Ω 1/4W J
R2901	QRE121J-331Y	C R	330Ω 1/2W J
△ R2902	QRF054K-3R3	UNF R	3.3Ω 5W K
△ R2903	QRF104K-3R9	UNF R	3.9Ω 10W K
R2904	QRL039J-683	OM R	68kΩ 3W J
R2905	QRE121J-474Y	C R	470kΩ 1/2W J
R2906	QRE121J-474Y	C R	470kΩ 1/2W J
R2908	QRL039J-823	OM R	82kΩ 3W J
R2909	QRL039J-823	OM R	82kΩ 3W J
△ R2910	QRE121J-150Y	C R	15Ω 1/2W J
R2911	QRE121J-152Y	C R	1.5kΩ 1/2W J
R2914	QRMO59J-R10	MP R	0.10Ω 5W J
R2915	QRE121J-681Y	C R	680Ω 1/2W J
R2916	QRE121J-332Y	C R	3.3kΩ 1/2W J
R2931	QRE141J-1R0Y	C R	1.0Ω 1/4W J
R2932	QRE141J-1R5Y	C R	1.5Ω 1/4W J
R2933	QRE141J-1R8Y	C R	1.8Ω 1/4W J
R2944	QRE141J-103Y	C R	10kΩ 1/4W J
R2945	QRE141J-563Y	C R	56kΩ 1/4W J
R2946	QRE141J-103Y	C R	10kΩ 1/4W J
R2951	QRE121J-102Y	C R	1kΩ 1/2W J
R2952	QRL039J-223	OM R	22kΩ 3W J
R2954	QRE141J-103Y	C R	10kΩ 1/4W J
R2959	QRT039J-R68	MF R	0.68Ω 3W J
R2961	QRE141J-332Y	C R	3.3kΩ 1/4W J
R2963	QRL039J-561	OM R	560Ω 3W J
R2964	QRT039J-1R5	MF R	1.5Ω 3W J
R2981	QRE141J-153Y	C R	15kΩ 1/4W J
R2982	QRE141J-102Y	C R	1kΩ 1/4W J
△ R2991	QRZ9046-825Z	C R	8.2MΩ 1/2W K

Symbol No.	Part No.	Part Name	Description
CAPACITOR			
C2404	QCZ0120-104Z	C CAP.	0.1μF 25V Z
C2405	QDC31HJ-820Z	C CAP.	82pF 50V J
C2406	QETM1VM-108	E CAP.	1000μF 35V M
C2408	QETM1VM-337Z	E CAP.	330μF 35V M
C2409	QFV71HJ-474Z	MF CAP.	0.47μF 50V J
C2410	QFV71HJ-474Z	MF CAP.	0.47μF 50V J
C2411	QFLC2AJ-104Z	M CAP.	0.1μF 100V J
C2414	QCB31HK-682Z	C CAP.	6800pF 50V K
C2421	QETN1HM-105Z	E CAP.	1μF 50V M
C2461	QEZO414-226	E CAP.	22μF 50V M
C2462	QFM72DJ-152Z	M CAP.	1500pF 200V J
C2463	QFM72DJ-122Z	M CAP.	1200pF 200V J
C2464	QCZ0120-104Z	C CAP.	0.1μF 25V Z
C2465	QETN1HM-106Z	E CAP.	10μF 50V M
C2466	QFP31HJ-272Z	PP CAP.	2700pF 50V J
C2467	QFLC1HJ-102Z	M CAP.	1000pF 50V J
C2468	QETN1EM-476Z	E CAP.	47μF 25V M
C2470	QCS31HJ-470Z	C CAP.	47pF 50V J
C2471	QFLC1HJ-103Z	M CAP.	0.01μF 50V J
C2501	QCB32HK-331Z	C CAP.	330pF 500V K
C2502	QFM72DK-103	M CAP.	0.01μF 200V K
C2503	QFV71HJ-224Z	MF CAP.	0.22μF 50V J
△ C2521	QFZ0122-112	MPP CAP.	1100pF1.8kVH±3%
△ C2522	QFZ0200-123	MPP CAP.	0.012μF1.5kVH±3%
C2523	QFM72DK-393	M CAP.	0.039μF 200V K
△ C2524	QFP32JJ-183	PP CAP.	0.018μF 630V J
C2526	QFZ0197-184	MPP CAP.	0.18μF 250V J
C2527	QFZ0194-104	MPP CAP.	0.1μF 250V J
C2529	QFZ0194-154	MPP CAP.	0.15μF 250V J
C2530	QCB32HK-561Z	C CAP.	560pF 500V K
C2531	QFZ0194-534	MPP CAP.	0.53μF 250V J
C2532	QETM2CM-227	E CAP.	220μF 160V M
C2533	QETN2EM-475Z	E CAP.	4.7μF 250V M
C2541	QENC1HM-105Z	E CAP.	1μF 50V M
C2551	QCB32HK-152Z	C CAP.	1500pF 500V K
C2552	QETN1CM-108Z	E CAP.	1000μF 16V M
C2553	QCB32HK-152Z	C CAP.	1500pF 500V K
C2554	QETN1CM-108Z	E CAP.	1000μF 16V M
C2555	QCB32HK-102Z	C CAP.	1000pF 500V K
C2556	QETN2EM-106Z	E CAP.	10μF 250V M
C2558	QETN1CM-477Z	E CAP.	470μF 16V M
C2559	QEHR1CM-227Z	E CAP.	220μF 16V M
C2561	QFLC2AJ-223Z	M CAP.	0.022μF 100V J
C2581	QETN1CM-107Z	E CAP.	100μF 16V M
C2582	QETN1EM-476Z	E CAP.	47μF 25V M
C2583	QETN2AM-106Z	E CAP.	10μF 100V M
C2584	QETN1AM-227Z	E CAP.	220μF 10V M

Symbol No.	Part No.	Part Name	Description
CAPACITOR			
△ C2901	QFZ9072-473	MF CAP.	0.047μFAC275V K
△ OR	QFZ9075-473	MPP CAP.	0.047μFAC275V M
△ C2902	QFZ9072-104	MF CAP.	0.1μFAC275V K
△ OR	QFZ9075-104	MPP CAP.	0.1μFAC275V M
△ C2903	QFZ9072-473	MF CAP.	0.047μFAC275V K
△ OR	QFZ9075-473	MPP CAP.	0.047μFAC275V M
△ C2904	QCZ9054-472	C CAP.	4700pFAC250V Z
△ C2905	QCZ9054-472	C CAP.	4700pFAC250V Z
△ C2906	QCZ9054-472	C CAP.	4700pFAC250V Z
C2907	QEZO199-227	E CAP.	220μF 400V M
C2908	QCB32HK-103	C CAP.	0.01μF 500V K
C2909	QCZ0340-391	C CAP.	390pF 2kV K
C2910	QETN1HM-476Z	E CAP.	47μF 50V M
C2911	QCB31HK-102Z	C CAP.	1000pF 50V K
C2912	QCZ0340-561	C CAP.	560pF 2kV K
C2914	QCB31HK-471Z	C CAP.	470pF 50V K
C2915	QFLC1HJ-104Z	M CAP.	0.1μF 50V J
C2916	QCB32HK-152Z	C CAP.	1500pF 500V K
△ C2931	QCZ9054-472	C CAP.	4700pFAC250V Z
△ C2933	QCZ9054-472	C CAP.	4700pFAC250V Z
C2934	QETM2GM-226	E CAP.	22μF 400V M
C2941	QTMN1CM-477Z	E CAP.	470μF 16V M
C2942	QETN1AM-337Z	E CAP.	330μF 10V M
C2951	QEZO203-227	E CAP.	220μF 160V M
C2952	QETN1CM-108Z	E CAP.	1000μF 16V M
C2954	QETM1VM-338	E CAP.	3300μF 35V M
C2955	QETM1VM-228	E CAP.	2200μF 35V M
C2956	QETN1AM-108Z	E CAP.	1000μF 10V M
C2957	QETN1AM-228Z	E CAP.	2200μF 10V M
C2959	QFV71HJ-684Z	MF CAP.	0.68μF 50V J
C2960	QCZ0325-821	C CAP.	820pF 2kV K
C2972	QETN1AM-477Z	E CAP.	470μF 10V M
C2973	QETN1AM-477Z	E CAP.	470μF 10V M
C2974	QETN0JM-228Z	E CAP.	2200μF 6.3V M
C2975	QETN1AM-228Z	E CAP.	2200μF 10V M
△ C2991	QCZ9079-222	C CAP.	2200pFAC250V M
△ C2993	QCZ9079-471	C CAP.	470pFAC250V K

Symbol No.	Part No.	Part Name	Description
TRANSFORMER			
T2501	QQR0882-001	DRIVE TRANSF.	
△ T2551	QQH0127-001	F.B. TRANSF.	
T2561	QQR1096-001	DEF TRANSF.	
△ T2901	QQS0176-001	SW TRANSF.	

Symbol No.	Part No.	Part Name	Description
COIL			
L2461	QQR1195-001	CHOKE COIL	
L2462	QQLZ028-272	INDUCTOR	
L2521	QQLZ031-180	INDUCTOR	
L2522	QQR1191-002	LINEARITY COIL	
L2552	QQLZ6AK-220Z	COIL	22μH K
L2561	QQLZ028-272	INDUCTOR	
L2901	QQL401K-100Z	COIL	10μH K
L2902	QQL401K-100Z	COIL	10μH K
L2903	QQR1200-001	CHOKE COIL	
L2951	QQLZ026-460	INDUCTOR	
L2959	QQLZ6AK-220Z	COIL	22μH K
L2960	QQLZ6AK-220Z	COIL	22μH K
L2961	QQLZ6AM-4R7Z	INDUCTOR	

Symbol No.	Part No.	Part Name	Description
DIODE			
D2402	1SR35-400A-T2	SI. DIODE	
D2421	1SS133-T2	SI. DIODE	
D2461	RGP10J-5025-T3	SI. DIODE	
D2462	1SS133-T2	SI. DIODE	
D2463	1SS133-T2	SI. DIODE	
D2501	1SS81-T5	SI. DIODE	
D2521	V11CA-C1	SI. DIODE	
D2522	FMV-3FU-F1	SI. DIODE	
D2523	MTZJ22B-T2	ZENER DIODE	
D2524	1SR35-400A-T2	SI. DIODE	
D2525	RGP10J-5025-T3	SI. DIODE	
D2541	RGP10J-5025-T3	SI. DIODE	
D2542	MTZJ3.9B-T2	ZENER DIODE	
D2551	RGP10J-5025-T3	SI. DIODE	
D2552	RGP10J-5025-T3	SI. DIODE	
D2553	RH15-T3	SI. DIODE	
D2582	MTZJ7.5B-T2	ZENER DIODE	
D2583	MTZJ7.5S-T2	ZENER DIODE	
△ D2584	RGP10J-5025-T3	SI. DIODE	

■ CRT SOCKET P.W. BOARD ASS'Y (SMF-3406A)

△ Symbol No.	Part No.	Part Name	Description
DIODE			
△ D2901	D35B60	BRIDGE DIODE	
D2902	RG1C-LFA1	SI. DIODE	
D2904	EU2A-T2	SI. DIODE	
D2905	1SS133-T2	SI. DIODE	
D2906	MTZJ27B-T2	ZENER DIODE	
D2907	1SS133-T2	SI. DIODE	
D2908	1SS133-T2	SI. DIODE	
D2910	MTZJ15B-T2	ZENER DIODE	
D2911	1SS133-T2	SI. DIODE	
△ D2931	S1NB/A/60-4101	BRIDGE DIODE	
D2945	1SS133-T2	SI. DIODE	
D2951	RU4AM-LFT1	SI. DIODE	
D2952	RU3YX-LFC4	SI. DIODE	
D2953	RU4AM-LFT2	SI. DIODE	
D2954	FMX-G12S	SI. DIODE	
D2955	RU3YX-LFC4	SI. DIODE	
D2956	RU3YX-LFC4	SI. DIODE	
D2958	MTZJ33B-T2	ZENER DIODE	
D2959	RU3YX-LFC4	SI. DIODE	
D2960	1SR124-400A-T2	SI. DIODE	
D2961	1SS133-T2	SI. DIODE	
D2981	1SS133-T2	SI. DIODE	
D2984	1SS133-T2	SI. DIODE	
D2985	1SS133-T2	SI. DIODE	

△ Symbol No.	Part No.	Part Name	Description
RESISTOR			
R3101	NRSA63J-223X	MG R	22kΩ 1/16W J
R3102	NRSA63J-681X	MG R	680Ω 1/16W J
R3103	NRSA63J-101X	MG R	100Ω 1/16W J
R3104	NRSA63J-822X	MG R	8.2kΩ 1/16W J
R3105	NRSA63J-102X	MG R	1kΩ 1/16W J
R3106	NRSA63J-221X	MG R	220Ω 1/16W J
R3107	NRSA63J-561X	MG R	560Ω 1/16W J
R3109	NRSA63J-153X	MG R	15kΩ 1/16W J
R3110	NRSA63J-222X	MG R	2.2kΩ 1/16W J
R3111	NRSA63J-182X	MG R	1.8kΩ 1/16W J
R3112	NRSA63J-272X	MG R	2.7kΩ 1/16W J
R3113	NRSA63J-331X	MG R	330Ω 1/16W J
R3114	NRSA63J-152X	MG R	1.5kΩ 1/16W J
R3115	NRSA63J-820X	MG R	82Ω 1/16W J
R3116	QRG01GJ-101	OM R	100Ω 1W J
R3117	NRSA63J-221X	MG R	220Ω 1/16W J
R3122	NRSA63J-122X	MG R	1.2kΩ 1/16W J
R3123	QRE121J-563Y	C R	56kΩ 1/2W J
R3124	NRSA63J-470X	MG R	47Ω 1/16W J
R3125	QRE121J-563Y	C R	56kΩ 1/2W J
R3126	NRSA63J-470X	MG R	47Ω 1/16W J
R3127	NRSA63J-122X	MG R	1.2kΩ 1/16W J
R3128	NRSA63J-390X	MG R	390Ω 1/16W J
R3129	QRE121J-2R7Y	C R	2.7Ω 1/2W J
R3130	QRE121J-2R7Y	C R	2.7Ω 1/2W J
R3131	NRSA63J-390X	MG R	390Ω 1/16W J
R3132	NRSA63J-121X	MG R	120Ω 1/16W J
R3133	QRL029J-391	OM R	390Ω 2W J
△ R3134	QRZ902J-561	F R	560 Ω 1W J
R3204	NRSA63J-272X	MG R	2.7kΩ 1/16W J
R3205	NRSA63J-272X	MG R	2.7kΩ 1/16W J
R3206	NRSA63J-272X	MG R	2.7kΩ 1/16W J
R3211	NRSA63J-154X	MG R	150kΩ 1/16W J
R3223	NRSA63J-272X	MG R	2.7kΩ 1/16W J
R3224	NRSA63J-272X	MG R	2.7kΩ 1/16W J
R3225	NRSA63J-272X	MG R	2.7kΩ 1/16W J
R3227	NRSA63J-103X	MG R	10kΩ 1/16W J
R3228	NRSA63J-272X	MG R	2.7kΩ 1/16W J
R3229	QRL029J-104-F	OM R	100kΩ 2W J
R3230	QRL029J-104-F	OM R	100kΩ 2W J
R3231	QRL029J-104-F	OM R	100kΩ 2W J
R3232	NRSA63J-332X	MG R	3.3kΩ 1/16W J
R3233	NRSA63J-332X	MG R	3.3kΩ 1/16W J
R3234	NRSA63J-332X	MG R	3.3kΩ 1/16W J
R3235	QRC121K-152Z	COMP. R	1.5kΩ 1/2W K
R3236	QRC121K-152Z	COMP. R	1.5kΩ 1/2W K
R3237	QRC121K-152Z	COMP. R	1.5kΩ 1/2W K
R3239	QRZ0107-474Z	C R	470kΩ 1/2W K
R3240	QRC121K-102Z	COMP. R	1kΩ 1/2W K
R3241	QRZ0107-105Z	C R	1.0MΩ 1/2W K
R3242	NRSA63J-103X	MG R	10kΩ 1/16W J
R3244	NRSA63J-102X	MG R	1kΩ 1/16W J
R3245	NRSA63J-562X	MG R	5.6kΩ 1/16W J
R3246	NRSA63J-562X	MG R	5.6kΩ 1/16W J
R3247	NRSA63J-562X	MG R	5.6kΩ 1/16W J
R3301	QRE121J-474Y	C R	470kΩ 1/2W J
R3302	QRE121J-474Y	C R	470kΩ 1/2W J
R3303	NRSA63J-223X	MG R	22kΩ 1/16W J
R3304	NRSA63J-223X	MG R	22kΩ 1/16W J
R3305	NRSA63J-562X	MG R	5.6kΩ 1/16W J
R3306	NRSA63J-392X	MG R	3.9kΩ 1/16W J
R3310	NRSA63J-OROX	MG R	0.0Ω 1/16W J

△ Symbol No.	Part No.	Part Name	Description
TRANSISTOR			
Q2421	DTC124ESA-T	DIGI. TRANSISTOR	
Q2422	2SC1740S/QR/-T	SI. TRANSISTOR	
Q2461	2SK2459N-F54	POWER MOS FET	
Q2462	2SC1740S/QR/-T	SI. TRANSISTOR	
Q2463	2SC1740S/QR/-T	SI. TRANSISTOR	
Q2464	2SA933AS/QR/-T	SI. TRANSISTOR	
Q2501	BSN304-T	MOS FET	
△ Q2521	2SC5905-RL	POWER TRANSISTOR	H. OUT
Q2581	2SA1208/ST/Z1-T	SI. TRANSISTOR	
Q2582	DTC144ESA-T	DIGI. TRANSISTOR	
Q2583	2SC1740S/QR/-T	SI. TRANSISTOR	
Q2941	2SC1740S/QR/-T	SI. TRANSISTOR	
Q2942	2SC1740S/QR/-T	SI. TRANSISTOR	

△ Symbol No.	Part No.	Part Name	Description
CAPACITOR			
C3102	NDC31HJ-8R0X	C CAP.	8.0pF 50V J
C3103	NDC31HJ-151X	C CAP.	150pF 50V J
C3104	QCB31HK-103Z	C CAP.	0.01μF 50V K
C3106	QETN1HM-335Z	E CAP.	3.3μF 50V M
C3107	QETN1CM-107Z	E CAP.	100μF 16V M
C3110	QETN2CM-106Z	E CAP.	10μF 160V M
C3111	QCB32HK-472Z	C CAP.	4700pF 500V K
C3113	QETN2CM-106Z	E CAP.	10μF 160V M
C3114	QCB32HK-472Z	C CAP.	4700pF 500V K
C3116	QETN1AM-107Z	E CAP.	100μF 10V M
C3117	QETN1AM-107Z	E CAP.	100μF 10V M
C3118	QETN1AM-337Z	E CAP.	330μF 10V M
C3120	NDC31HJ-221X	C CAP.	220pF 50V J
C3121	NDC31HJ-221X	C CAP.	220pF 50V J
C3201	NDC31HJ-8R0X	C CAP.	8.0pF 50V J

△ Symbol No.	Part No.	Part Name	Description
IC			
IC2401	AN5523	IC	
IC2461	BA10393	IC	
IC2551	BA12T	IC	
IC2901	STR-F6667B/F7	IC	
△ IC2902	QAL0425-001	POWER MODULE	
IC2951	SE140N	IC	
IC2954	BA05T	IC	
IC2955	NJM2396F33	IC	

△ Symbol No.	Part No.	Part Name	Description
OTHERS			
△ CP2951	ICP-N75-Y	I. C. PROTECT	
△ CP2952	ICP-N75-Y	I. C. PROTECT	
△ CP2953	ICP-N75-Y	I. C. PROTECT	
△ CP2954	QMFZ049-4R0Z-E	FUSE	4.0A
△ CP2955	ICP-N75-Y	I. C. PROTECT	
K2401	QQR0621-002Z	FERRITE BEADS	
K2522	CE41832-001	LEAD CORE	
K2523	CE41832-001	LEAD CORE	
K2524	CE41832-001	LEAD CORE	
K2901	QQR0679-001	FERRITE BEADS	
△ LF2901	QQR1095-001	LINE FILTER	
△ PC2901	PC123FY2	IC (PHOTO COUPLE	
△ RY2931	QSK0099-001	RELAY	
△ TH2901	QAD0133-9R0	THERMISTOR	

Symbol No.	Part No.	Part Name	Description
CAPACITOR			
C3202	NDC31HJ-880X	C CAP.	8.0pF 50V J
C3203	NDC31HJ-880X	C CAP.	8.0pF 50V J
C3204	NCF31CZ-104X	C CAP.	0.1μF 16V Z
C3205	NCF31CZ-104X	C CAP.	0.1μF 16V Z
C3206	NCF31CZ-104X	C CAP.	0.1μF 16V Z
C3207	QETN1EM-476Z	E CAP.	47μF 25V M
C3208	QETN1EM-476Z	E CAP.	47μF 25V M
C3209	QETN1EM-476Z	E CAP.	47μF 25V M
C3210	QFK62EK-104Z	MM CAP.	0.1μF 250V K
C3211	QFK62EK-104Z	MM CAP.	0.1μF 250V K
C3212	QFK62EK-104Z	MM CAP.	0.1μF 250V K
C3213	NDC31HJ-181X	C CAP.	180pF 50V J
C3214	NDC31HJ-181X	C CAP.	180pF 50V J
C3215	NDC31HJ-181X	C CAP.	180pF 50V J
C3216	QETN1CM-107Z	E CAP.	100μF 16V M
C3218	QETM2EM-336	E CAP.	33μF 250V M
C3219	QFZ0097-223	MM CAP.	0.022μF 1250V K
C3221	QETN2EM-106Z	E CAP.	10μF 250V M
C3302	QETN1HM-106Z	E CAP.	10μF 50V M
COIL			
L3101	QQL244K-5R6Z	COIL	5.6μH K
L3201	IM-BW	BUS WIRE	
L3202	IM-BW	BUS WIRE	
L3203	IM-BW	BUS WIRE	
L3204	QQL26AJ-102Z	COIL	1mH J
DIODE			
D3101	MA111-X	SI. DIODE	
D3102	MA111-X	SI. DIODE	
D3103	RH15-T3	SI. DIODE	
D3104	RH15-T3	SI. DIODE	
D3204	EU01N-T2	SI. DIODE	
D3205	EU01N-T2	SI. DIODE	
D3206	EU01N-T2	SI. DIODE	
D3207	RM2C-LFA1	SI. DIODE	
D3208	1SR124-400A-T2	SI. DIODE	
D3209	1SR124-400A-T2	SI. DIODE	
D3210	1SR124-400A-T2	SI. DIODE	
D3211	MA3062/M/-X	ZENER DIODE	
D3212	MA3130/H/-X	ZENER DIODE	
D3213	MA3130/H/-X	ZENER DIODE	
D3301	MA111-X	SI. DIODE	
D3303	MA111-X	SI. DIODE	
TRANSISTOR			
Q3101	2SC2412K/QR/-X	SI. TRANSISTOR	
Q3102	2SA1037AK/QR/-X	SI. TRANSISTOR	
Q3103	2SC1906-T	SI. TRANSISTOR	
Q3104	2SC2412K/QR/-X	SI. TRANSISTOR	
Q3105	2SC1627A/OY/-T	SI. TRANSISTOR	
Q3108	2SA1837	POWER TRANSISTO	
Q3109	2SC4793	POWER TRANSISTO	
Q3301	2SA1037AK/QR/-X	SI. TRANSISTOR	
IC			
IC3201	TDA6111Q	I C	
IC3202	TDA6111Q	I C	
IC3203	TDA6111Q	I C	
OTHERS			
CN3013	CHGY0146-0A-G	CONNECTOR ASSY	
CN3014	QJK002-063631	SIN CR C-B WIRE	
K3101	CE41492-001Z	CHOKE COIL	
K3103	CE41492-001Z	CHOKE COIL	
K3104	CE41492-001Z	CHOKE COIL	
K3105	QQR0621-002Z	FERRITE BEADS	
SG3201	QAF0056-501Z	SURGE ABSORBER	
SG3202	QAF0056-501Z	SURGE ABSORBER	
SG3203	QAF0056-501Z	SURGE ABSORBER	
△ SK3001	QNZ0380-001	CRT SOCKET	
W3003	QQR0679-001	FERRITE BEADS	
W3022	QQR0679-001	FERRITE BEADS	

FRONT CONTROL P.W. BOARD ASS'Y (SMF-8405A)

Symbol No.	Part No.	Part Name	Description
RESISTOR			
R8005	NRSA63J-221X	MG R	220Ω 1/16W J
R8008	NRSA63J-102X	MG R	1kΩ 1/16W J
R8039	NRSA63J-331X	MG R	330Ω 1/16W J
CAPACITOR			
C8004	NCB31CK-104X	C CAP.	0.1μF 16V K
C8022	QETN1EM-476Z	E CAP.	47μF 25V M
△ C8901	QFZ9072-474	MM CAP.	0.47μFAC275V M
△ OR	QFZ9075-474	MPP CAP.	0.47μFAC275V M
DIODE			
D8010	SPR-39MWF	LED	
D8011	MA111-X	SI. DIODE	
D8014	MA3068/M/-X	ZENER DIODE	
TRANSISTOR			
Q8002	DTC124EKA-X	DIGI. TRANSISTOR	
Q8003	DTA124EKA-X	DIGI. TRANSISTOR	
Q8004	DTA124EKA-X	DIGI. TRANSISTOR	
IC			
IC8001	GP1U281Q	IR DETECT UNIT	
OTHERS			
	LC30349-001A-H	LED HOLDER	
	CEMG002-001Z	FUSE CLIP	x2
CN8102	QGF1220C2-25	FFC/FPC CONNE	
△ F8901	QMF51D2-3R15J1	FUSE	3.15A
△ LF8901	QQR1095-001	LINE FILTER	
△ S8901	QSW0824-001	PUSH SWITCH	MAIN POWER
SIDE CONTROL P.W. BOARD ASS'Y (SMF-8106A)			
Symbol No.	Part No.	Part Name	Description
RESISTOR			
R8001	QRE121J-271Y	C R	270Ω 1/2W J
R8002	QRE121J-271Y	C R	270Ω 1/2W J
R8007	NRSA63J-103X	MG R	10kΩ 1/16W J
R8010	NRSA63J-103X	MG R	10kΩ 1/16W J
R8012	NRSA63J-103X	MG R	10kΩ 1/16W J
R8013	NRSA63J-103X	MG R	10kΩ 1/16W J
R8021	NRSA63J-102X	MG R	1kΩ 1/16W J
R8022	NRSA63J-102X	MG R	1kΩ 1/16W J
CAPACITOR			
C8001	NCB31HK-103X	C CAP.	0.01μF 50V K
C8002	NCB31HK-103X	C CAP.	0.01μF 50V K
C8003	NDC31HJ-680X	C CAP.	68pF 50V J
C8010	NCB31HK-472X	C CAP.	4700pF 50V K
C8011	NCB31HK-472X	C CAP.	4700pF 50V K
C8021	NCB31CK-104X	C CAP.	0.1μF 16V K
COIL			
L8001	QQR0716-001Z	FERRITE BEADS	
L8002	QQL244K-5R6Z	COIL	5.6μH K
L8003	QQL244K-5R6Z	COIL	5.6μH K
L8010	QQL244K-270Z	COIL	27μH K
L8011	QQL244K-270Z	COIL	27μH K
L8012	QQR0716-001Z	FERRITE BEADS	
OTHERS			
J8001	QMS3001-C01	3.5 JACK	
J8003	QNZ0438-001	AV JACK	
LC8002	NQRO169-001X	EMI FILTER	
S8001	QSW0619-003Z	TACT SWITCH	MENU
S8002	QSW0619-003Z	TACT SWITCH	CH DOWN
S8003	QSW0619-003Z	TACT SWITCH	CH UP

■ DOLBY P.W. BOARD ASS'Y (SMF-0D401A)

△ Symbol No.	Part No.	Part Name	Description
RESISTOR			
R0101	NRSA63J-750X	MG R	75Ω 1/16W J
R0102	NRSA63J-221X	MG R	220Ω 1/16W J
R0105	NRSA63J-101X	MG R	100Ω 1/16W J
R0106	NRSA63J-225X	MG R	2.2MΩ 1/16W J
R0107	NRSA63J-472X	MG R	4.7kΩ 1/16W J
R0108	NRSA63J-103X	MG R	10kΩ 1/16W J
R0109	NRSA63J-102X	MG R	1kΩ 1/16W J
R0110	NRSA63J-101X	MG R	100Ω 1/16W J
R0111	NRSA63J-102X	MG R	1kΩ 1/16W J
R0112	NRSA63J-563X	MG R	56kΩ 1/16W J
R0113	NRSA63J-103X	MG R	10kΩ 1/16W J
R0114	NRSA63J-472X	MG R	4.7kΩ 1/16W J
R0115	NRSA63J-103X	MG R	10kΩ 1/16W J
R0116	NRSA63J-101X	MG R	100Ω 1/16W J
R0117	NRSA63J-101X	MG R	100Ω 1/16W J
R0118	NRSA63J-101X	MG R	100Ω 1/16W J
R0122	NRSA63J-0R0X	MG R	0.0Ω 1/16W J
R0123	NRSA63J-682X	MG R	6.8kΩ 1/16W J
R0124	NRSA63J-332X	MG R	3.3kΩ 1/16W J
R0125	NRSA63J-473X	MG R	47kΩ 1/16W J
R0126	NRSA63J-473X	MG R	47kΩ 1/16W J
R0127	NRSA63J-221X	MG R	220Ω 1/16W J
R0128	NRSA63J-221X	MG R	220Ω 1/16W J
R0129	NRSA63J-221X	MG R	220Ω 1/16W J
R0130	NRSA63J-221X	MG R	220Ω 1/16W J
R0131	NRSA63J-221X	MG R	220Ω 1/16W J
R0132	NRSA63J-221X	MG R	220Ω 1/16W J
R0133	NRSA63J-472X	MG R	4.7kΩ 1/16W J
R0134	NRSA63J-473X	MG R	47kΩ 1/16W J
R0135	NRSA63J-473X	MG R	47kΩ 1/16W J
R0136	NRSA63J-473X	MG R	47kΩ 1/16W J
R0137	NRSA63J-221X	MG R	220Ω 1/16W J
R0138	NRSA63J-221X	MG R	220Ω 1/16W J
R0139	NRSA63J-221X	MG R	220Ω 1/16W J
R0140	NRSA63J-221X	MG R	220Ω 1/16W J
R0141	NRSA63J-103X	MG R	10kΩ 1/16W J
R0144	NRSA63J-473X	MG R	47kΩ 1/16W J
R0145	NRSA63J-103X	MG R	10kΩ 1/16W J
R0148	NRSA63J-332X	MG R	3.3kΩ 1/16W J
R0149	NRSA63J-0R0X	MG R	0.0Ω 1/16W J
R0150	NRSA63J-103X	MG R	10kΩ 1/16W J
R0155	NRSA63J-101X	MG R	100Ω 1/16W J
R0160	NRSA63J-0R0X	MG R	0.0Ω 1/16W J
R0161	NRSA63J-472X	MG R	4.7kΩ 1/16W J
R0162	NRSA63J-183X	MG R	18kΩ 1/16W J
R0163	NRSA63J-103X	MG R	10kΩ 1/16W J
R0164	NRSA63J-103X	MG R	10kΩ 1/16W J
R0165	NRSA63J-103X	MG R	10kΩ 1/16W J
R0201	NRSA63J-104X	MG R	100kΩ 1/16W J
R0202	NRSA63J-104X	MG R	100kΩ 1/16W J
R0203	NRSA63J-273X	MG R	27kΩ 1/16W J
R0204	NRSA63J-273X	MG R	27kΩ 1/16W J
R0205	NRSA63J-682X	MG R	6.8kΩ 1/16W J
R0206	NRSA63J-682X	MG R	6.8kΩ 1/16W J
R0207	NRSA63J-102X	MG R	1kΩ 1/16W J
R0208	NRSA63J-102X	MG R	1kΩ 1/16W J
R0209	NRSA63J-102X	MG R	1kΩ 1/16W J
R0210	NRSA63J-102X	MG R	1kΩ 1/16W J
R0211	NRSA63J-102X	MG R	1kΩ 1/16W J
R0212	NRSA63J-102X	MG R	1kΩ 1/16W J
R0213	NRSA63J-102X	MG R	1kΩ 1/16W J
R0215	NRSA63J-103X	MG R	10kΩ 1/16W J
R0216	NRSA63J-103X	MG R	10kΩ 1/16W J
R0217	NRSA63J-103X	MG R	10kΩ 1/16W J
R0218	NRSA63J-103X	MG R	10kΩ 1/16W J
R0219	NRSA63J-102X	MG R	1kΩ 1/16W J
R0220	NRSA63J-102X	MG R	1kΩ 1/16W J
R0223	NRSA63J-102X	MG R	1kΩ 1/16W J
R0301	NRSA63J-222X	MG R	2.2kΩ 1/16W J
R0302	NRSA63J-103X	MG R	10kΩ 1/16W J
R0303	NRSA63J-223X	MG R	22kΩ 1/16W J
R0304	NRSA63J-222X	MG R	2.2kΩ 1/16W J
R0305	NRSA63J-223X	MG R	22kΩ 1/16W J
R0306	NRSA63J-103X	MG R	10kΩ 1/16W J
R0307	NRSA63J-103X	MG R	10kΩ 1/16W J
R0308	NRSA63J-104X	MG R	100kΩ 1/16W J
R0309	NRSA63J-104X	MG R	100kΩ 1/16W J
R0310	NRSA63J-103X	MG R	10kΩ 1/16W J
R0311	NRSA63J-222X	MG R	2.2kΩ 1/16W J

△ Symbol No.	Part No.	Part Name	Description
RESISTOR			
R0312	NRSA63J-223X	MG R	22kΩ 1/16W J
R0313	NRSA63J-103X	MG R	10kΩ 1/16W J
R0314	NRSA63J-104X	MG R	100kΩ 1/16W J
R0315	NRSA63J-103X	MG R	10kΩ 1/16W J
R0316	NRSA63J-104X	MG R	100kΩ 1/16W J
R0317	NRSA63J-103X	MG R	10kΩ 1/16W J
R0318	NRSA63J-223X	MG R	22kΩ 1/16W J
R0319	NRSA63J-222X	MG R	2.2kΩ 1/16W J
R0320	NRSA63J-223X	MG R	22kΩ 1/16W J
R0321	NRSA63J-103X	MG R	10kΩ 1/16W J
R0322	NRSA63J-103X	MG R	10kΩ 1/16W J
R0323	NRSA63J-222X	MG R	2.2kΩ 1/16W J
R0324	NRSA63J-104X	MG R	100kΩ 1/16W J
R0325	NRSA63J-104X	MG R	100kΩ 1/16W J
R0326	NRSA63J-123X	MG R	12kΩ 1/16W J
R0327	NRSA63J-273X	MG R	27kΩ 1/16W J
R0328	NRSA63J-822X	MG R	8.2kΩ 1/16W J
R0329	NRSA63J-103X	MG R	10kΩ 1/16W J
R0330	NRSA63J-104X	MG R	100kΩ 1/16W J
R0401	NRSA63J-0R0X	MG R	0.0Ω 1/16W J
R0402	NRSA63J-104X	MG R	100kΩ 1/16W J
R0403	NRSA63J-223X	MG R	22kΩ 1/16W J
R0405	NRSA63J-103X	MG R	10kΩ 1/16W J
R0406	NRSA63J-103X	MG R	10kΩ 1/16W J
R0407	NRSA63J-104X	MG R	100kΩ 1/16W J
R0408	NRSA63J-223X	MG R	22kΩ 1/16W J
R0409	NRSA63J-0R0X	MG R	0.0Ω 1/16W J
R0410	NRSA63J-103X	MG R	10kΩ 1/16W J
R0411	NRSA63J-273X	MG R	27kΩ 1/16W J
R0412	NRSA63J-103X	MG R	10kΩ 1/16W J
R0413	NRSA63J-104X	MG R	100kΩ 1/16W J
R0414	NRSA63J-103X	MG R	10kΩ 1/16W J
R0415	NRSA63J-103X	MG R	10kΩ 1/16W J
R0416	NRSA63J-0R0X	MG R	0.0Ω 1/16W J
R0417	NRSA63J-104X	MG R	100kΩ 1/16W J
R0418	NRSA63J-0R0X	MG R	0.0Ω 1/16W J
R0419	NRSA63J-563X	MG R	56kΩ 1/16W J
R0420	NRSA63J-563X	MG R	56kΩ 1/16W J
R0421	NRSA63J-563X	MG R	56kΩ 1/16W J
R0422	NRSA63J-563X	MG R	56kΩ 1/16W J
R0423	NRSA63J-563X	MG R	56kΩ 1/16W J
R0424	NRSA63J-563X	MG R	56kΩ 1/16W J
R0425	NRSA63J-563X	MG R	56kΩ 1/16W J
R0426	NRSA63J-273X	MG R	27kΩ 1/16W J
R0427	NRSA63J-273X	MG R	27kΩ 1/16W J
R0428	NRSA63J-563X	MG R	56kΩ 1/16W J
R0429	NRSA63J-104X	MG R	100kΩ 1/16W J
R0430	NRSA63J-104X	MG R	100kΩ 1/16W J
R0431	NRSA63J-104X	MG R	100kΩ 1/16W J
R0432	NRSA63J-104X	MG R	100kΩ 1/16W J
R0433	NRSA63J-104X	MG R	100kΩ 1/16W J
R0434	NRSA63J-104X	MG R	100kΩ 1/16W J
R0435	NRSA63J-104X	MG R	100kΩ 1/16W J
R0436	NRSA63J-104X	MG R	100kΩ 1/16W J
R0501	NRSA63J-103X	MG R	10kΩ 1/16W J
R0502	NRSA63J-332X	MG R	3.3kΩ 1/16W J
R0601	NRSA63J-394X	MG R	390kΩ 1/16W J
R0602	NRSA63J-471X	MG R	470Ω 1/16W J
R0603	NRSA63J-394X	MG R	390kΩ 1/16W J
R0604	NRSA63J-471X	MG R	470Ω 1/16W J
R0605	NRSA63J-562X	MG R	5.6kΩ 1/16W J
R0606	NRSA63J-562X	MG R	5.6kΩ 1/16W J
R0631	NRSA63J-562X	MG R	5.6kΩ 1/16W J
R0632	NRSA63J-394X	MG R	390kΩ 1/16W J
R0633	NRSA63J-471X	MG R	470Ω 1/16W J
R0634	NRSA63J-471X	MG R	470Ω 1/16W J
R0651	NRSA63J-394X	MG R	390kΩ 1/16W J
R0652	NRSA63J-471X	MG R	470Ω 1/16W J
R0653	NRSA63J-394X	MG R	390kΩ 1/16W J
R0654	NRSA63J-471X	MG R	470Ω 1/16W J
R0655	NRSA63J-562X	MG R	5.6kΩ 1/16W J
R0656	NRSA63J-562X	MG R	5.6kΩ 1/16W J
R0657	NRSA63J-103X	MG R	10kΩ 1/16W J
R0658	NRSA63J-103X	MG R	10kΩ 1/16W J
R0701	NRSA63J-103X	MG R	10kΩ 1/16W J
R0702	NRSA63J-103X	MG R	10kΩ 1/16W J
R0703	NRSA63J-103X	MG R	10kΩ 1/16W J
R0704	NRSA63J-153X	MG R	15kΩ 1/16W J
R0705	NRSA63J-103X	MG R	10kΩ 1/16W J

Symbol No.	Part No.	Part Name	Description
RESISTOR			
R0706	NRSA63J-104X	MG R	100kΩ 1/16W J
R0707	NRSA63J-153X	MG R	15kΩ 1/16W J
R0708	NRSA63J-103X	MG R	10kΩ 1/16W J
R0709	NRSA63J-104X	MG R	100kΩ 1/16W J
R0710	NRSA63J-681X	MG R	680Ω 1/16W J
R0711	NRSA63J-681X	MG R	680Ω 1/16W J
R0712	NRSA63J-103X	MG R	10kΩ 1/16W J
R0713	NRSA63J-103X	MG R	10kΩ 1/16W J
R0714	NRSA63J-681X	MG R	680Ω 1/16W J
R0715	NRSA63J-104X	MG R	100kΩ 1/16W J
R0716	NRSA63J-153X	MG R	15kΩ 1/16W J
R0717	NRSA63J-104X	MG R	100kΩ 1/16W J
R0718	NRSA63J-103X	MG R	10kΩ 1/16W J
R0719	NRSA63J-103X	MG R	10kΩ 1/16W J
R0720	NRSA63J-0R0X	MG R	0.0Ω 1/16W J
R0721	NRSA63J-104X	MG R	100kΩ 1/16W J
R0723	NRSA63J-0R0X	MG R	0.0Ω 1/16W J
R0724	NRSA63J-103X	MG R	10kΩ 1/16W J
R0726	NRSA63J-104X	MG R	100kΩ 1/16W J
R0727	NRSA63J-104X	MG R	100kΩ 1/16W J
R0728	NRSA63J-104X	MG R	100kΩ 1/16W J
R0729	NRSA63J-104X	MG R	100kΩ 1/16W J
R0730	NRSA63J-103X	MG R	10kΩ 1/16W J
R0731	NRSA63J-104X	MG R	100kΩ 1/16W J
R0732	NRSA63J-472X	MG R	4.7kΩ 1/16W J
R0733	NRSA63J-223X	MG R	22kΩ 1/16W J
R0734	NRSA63J-223X	MG R	22kΩ 1/16W J
R0735	NRSA63J-103X	MG R	10kΩ 1/16W J
R0736	NRSA63J-104X	MG R	100kΩ 1/16W J
R0737	NRSA63J-223X	MG R	22kΩ 1/16W J
R0739	NRSA63J-103X	MG R	10kΩ 1/16W J
R0740	NRSA63J-104X	MG R	100kΩ 1/16W J
R0741	NRSA63J-104X	MG R	100kΩ 1/16W J
R0742	NRSA63J-104X	MG R	100kΩ 1/16W J
R0743	NRSA63J-472X	MG R	4.7kΩ 1/16W J
R0744	NRSA63J-223X	MG R	22kΩ 1/16W J
R0745	NRSA63J-223X	MG R	22kΩ 1/16W J
R0746	NRSA63J-223X	MG R	22kΩ 1/16W J
R0747	NRSA63J-472X	MG R	4.7kΩ 1/16W J

Symbol No.	Part No.	Part Name	Description
CAPACITOR			
C0101	NDC31HJ-101X	C CAP.	100pF 50V J
C0102	NEH71HM-105X	E CAP.	1μF 50V M
C0103	NCB31HK-103X	C CAP.	0.01μF 50V K
C0104	NCB31HK-104X	C CAP.	0.1μF 50V K
C0105	NEH71CM-476X	E CAP.	47μF 16V M
C0106	NCB31HK-103X	C CAP.	0.01μF 50V K
C0107	NEH70JM-107X	E CAP.	100μF 6.3V M
C0108	NCB31HK-103X	C CAP.	0.01μF 50V K
C0109	NCB31HK-103X	C CAP.	0.01μF 50V K
C0110	NCB31HK-104X	C CAP.	0.1μF 50V K
C0111	NCB31HK-104X	C CAP.	0.1μF 50V K
C0112	NCB31CK-104X	C CAP.	0.1μF 16V K
C0113	NDC31HJ-121X	C CAP.	120pF 50V J
C0114	NDC31HJ-101X	C CAP.	100pF 50V J
C0115	NCB31HK-103X	C CAP.	0.01μF 50V K
C0116	NCB31AK-474X	C CAP.	0.47μF 10V K
C0117	NCB31HK-103X	C CAP.	0.01μF 50V K
C0118	NEH70JM-107X	E CAP.	100μF 6.3V M
C0119	NEH71CM-476X	E CAP.	47μF 16V M
C0120	NCB31HK-104X	C CAP.	0.1μF 50V K
C0121	NEH71CM-476X	E CAP.	47μF 16V M
C0122	NCB31HK-104X	C CAP.	0.1μF 50V K
C0123	NCB31HK-102X	C CAP.	1000pF 50V K
C0124	NCB31HK-102X	C CAP.	1000pF 50V K
C0125	NEH71CM-476X	E CAP.	47μF 16V M
C0126	NCB31HK-104X	C CAP.	0.1μF 50V K
C0129	NCB31HK-103X	C CAP.	0.01μF 50V K
C0130	NDC31HJ-101X	C CAP.	100pF 50V J
C0131	NCB31HK-103X	C CAP.	0.01μF 50V K
C0132	NEH70JM-107X	E CAP.	100μF 6.3V M
C0133	NCB31HK-103X	C CAP.	0.01μF 50V K
C0134	NEH70JM-107X	E CAP.	100μF 6.3V M
C0137	NEH70JM-107X	E CAP.	100μF 6.3V M
C0138	NCB31HK-104X	C CAP.	0.1μF 50V K
C0139	NCB31HK-104X	C CAP.	0.1μF 50V K
C0140	NDC31HJ-180X	C CAP.	18pF 50V J
C0141	NDC31HJ-220X	C CAP.	22pF 50V J
C0142	NCB31CK-104X	C CAP.	0.1μF 16V K

Symbol No.	Part No.	Part Name	Description
CAPACITOR			
C0143	NCB31CK-104X	C CAP.	0.1μF 16V K
C0145	NDC31HJ-101X	C CAP.	100pF 50V J
C0146	NCB31CK-104X	C CAP.	0.1μF 16V K
C0149	NCB31HK-104X	C CAP.	0.1μF 50V K
C0150	NDC31HJ-470X	C CAP.	47pF 50V J
C0201	NEH71EM-475X	E CAP.	4.7μF 25V M
C0202	NEH71EM-475X	E CAP.	4.7μF 25V M
C0203	NDC31HJ-560X	C CAP.	56pF 50V J
C0204	NCB31HK-104X	C CAP.	0.1μF 50V K
C0207	NDC31HJ-560X	C CAP.	56pF 50V J
C0208	NCB31HK-183X	C CAP.	0.018μF 50V K
C0209	NCB31HK-183X	C CAP.	0.018μF 50V K
C0210	NCB31HK-182X	C CAP.	1800pF 50V K
C0211	NCB31HK-104X	C CAP.	0.1μF 50V K
C0213	NCB31AK-474X	C CAP.	0.47μF 10V K
C0214	NCB31HK-182X	C CAP.	1800pF 50V K
C0215	NCB31HK-562X	C CAP.	5600pF 50V K
C0216	NCB31HK-562X	C CAP.	5600pF 50V K
C0218	NDC31HJ-560X	C CAP.	56pF 50V J
C0219	NCB31HK-104X	C CAP.	0.1μF 50V K
C0220	NCB31HK-562X	C CAP.	5600pF 50V K
C0221	NCB31HK-562X	C CAP.	5600pF 50V K
C0223	NDC31HJ-560X	C CAP.	56pF 50V J
C0224	NEH71CM-476X	E CAP.	47μF 16V M
C0225	NEH71CM-476X	E CAP.	47μF 16V M
C0226	NCB31HK-103X	C CAP.	0.01μF 50V K
C0301	NCF31AZ-105X	C CAP.	1μF 10V Z
C0302	NCB31HK-104X	C CAP.	0.1μF 50V K
C0303	NCB31HK-222X	C CAP.	2200pF 50V K
C0304	NDC31HJ-560X	C CAP.	56pF 50V J
C0305	NCF31AZ-105X	C CAP.	1μF 10V Z
C0307	NDC31HJ-560X	C CAP.	56pF 50V J
C0308	NCB31HK-222X	C CAP.	2200pF 50V K
C0309	NDC31HJ-220X	C CAP.	22pF 50V J
C0310	NCB31HK-104X	C CAP.	0.1μF 50V K
C0311	NCB31HK-222X	C CAP.	2200pF 50V K
C0312	NCB31HK-222X	C CAP.	2200pF 50V K
C0313	NDC31HJ-220X	C CAP.	22pF 50V J
C0314	NCF31AZ-105X	C CAP.	1μF 10V Z
C0315	NCF31AZ-105X	C CAP.	1μF 10V Z
C0316	NDC31HJ-220X	C CAP.	22pF 50V J
C0317	NCF31AZ-105X	C CAP.	1μF 10V Z
C0318	NCF31AZ-105X	C CAP.	1μF 10V Z
C0319	NDC31HJ-220X	C CAP.	22pF 50V J
C0320	NCB31CK-104X	C CAP.	0.1μF 16V K
C0321	NCB31HK-222X	C CAP.	2200pF 50V K
C0401	NEH71HM-106X	E CAP.	10μF 50V M
C0402	NEH71HM-106X	E CAP.	10μF 50V M
C0403	NCB31HK-103X	C CAP.	0.01μF 50V K
C0405	NCF31AZ-105X	C CAP.	1μF 10V Z
C0406	NDC31HJ-560X	C CAP.	56pF 50V J
C0407	NDC31HJ-560X	C CAP.	56pF 50V J
C0408	NCF31AZ-105X	C CAP.	1μF 10V Z
C0409	NDC31HJ-560X	C CAP.	56pF 50V J
C0410	NCF31AZ-105X	C CAP.	1μF 10V Z
C0411	NCF31AZ-105X	C CAP.	1μF 10V Z
C0412	NDC31HJ-560X	C CAP.	56pF 50V J
C0413	NDC31HJ-560X	C CAP.	56pF 50V J
C0414	NCF31AZ-105X	C CAP.	1μF 10V Z
C0415	NCF31AZ-105X	C CAP.	1μF 10V Z
C0416	NCF31AZ-105X	C CAP.	1μF 10V Z
C0417	NEH71CM-476X	E CAP.	47μF 16V M
C0440	NCB31HK-104X	C CAP.	0.1μF 50V K
C0441	NCB31HK-104X	C CAP.	0.1μF 50V K
C0442	NCB31HK-104X	C CAP.	0.1μF 50V K
C0443	NCB31HK-104X	C CAP.	0.1μF 50V K
C0551	NCB31HK-103X	C CAP.	0.01μF 50V K
C0552	NCB31CK-104X	C CAP.	0.1μF 16V K
C0553	NEH70JM-107X	E CAP.	100μF 6.3V M
C0558	NEH70JM-107X	E CAP.	100μF 6.3V M
C0559	NCB31HK-103X	C CAP.	0.01μF 50V K
C0601	NEH71CM-476X	E CAP.	47μF 16V M
C0602	NCB31CK-104X	C CAP.	0.1μF 16V K
C0603	NCB31CK-104X	C CAP.	0.1μF 16V K
C0604	NCB31CK-104X	C CAP.	0.1μF 16V K
C0605	NCB31CK-104X	C CAP.	0.1μF 16V K
C0606	NCB31HK-222X	C CAP.	2200pF 50V K
C0607	NCB31HK-222X	C CAP.	2200pF 50V K
C0608	NCF31AZ-105X	C CAP.	1μF 10V Z
C0612	NEH71EM-226X	E CAP.	22μF 25V M
C0613	NCF31AZ-105X	C CAP.	1μF 10V Z
C0631	NEH71CM-476X	E CAP.	47μF 16V M

Symbol No.	Part No.	Part Name	Description
CAPACITOR			
C0632	NEH71EM-226X	E CAP.	22µF 25V M
C0633	NCF31AZ-105X	C CAP.	1µF 10V Z
C0634	NCF31AZ-105X	C CAP.	1µF 10V Z
C0635	NCB31CK-104X	C CAP.	0.1µF 16V K
C0636	NCB31CK-104X	C CAP.	0.1µF 16V K
C0637	NCB31HK-222X	C CAP.	2200pF 50V K
C0638	NCB31HK-222X	C CAP.	2200pF 50V K
C0651	NEH71CM-476X	E CAP.	47µF 16V M
C0652	NEH71EM-226X	E CAP.	22µF 25V M
C0653	NCF31AZ-105X	C CAP.	1µF 10V Z
C0654	NCF31AZ-105X	C CAP.	1µF 10V Z
C0655	NCB31HK-222X	C CAP.	2200pF 50V K
C0656	NCB31HK-222X	C CAP.	2200pF 50V K
C0657	NCB31CK-104X	C CAP.	0.1µF 16V K
C0658	NCB31CK-104X	C CAP.	0.1µF 16V K
C0659	NCB31CK-104X	C CAP.	0.1µF 16V K
C0660	NCB31CK-104X	C CAP.	0.1µF 16V K
C0701	NCF31AZ-105X	C CAP.	1µF 10V Z
C0702	NCF31AZ-105X	C CAP.	1µF 10V Z
C0703	NEH71HM-106X	E CAP.	10µF 50V M
C0704	NDC31HJ-100X	C CAP.	10pF 50V J
C0705	NDC31HJ-100X	C CAP.	10pF 50V J
C0706	NEH71HM-106X	E CAP.	10µF 50V M
C0707	NEH71HM-106X	E CAP.	10µF 50V M
C0708	NCB31HK-222X	C CAP.	2200pF 50V K
C0709	NCB31HK-222X	C CAP.	2200pF 50V K
C0710	NEH71HM-106X	E CAP.	10µF 50V M
C0711	NCB31HK-222X	C CAP.	2200pF 50V K
C0712	NEH71HM-106X	E CAP.	10µF 50V M
C0713	NEH71HM-106X	E CAP.	10µF 50V M
C0714	NEH71HM-106X	E CAP.	10µF 50V M
C0715	NDC31HJ-470X	C CAP.	47pF 50V J
C0716	NCF31AZ-105X	C CAP.	1µF 10V Z
C0717	NCB31HK-103X	C CAP.	0.01µF 50V K
C0718	NCF31AZ-105X	C CAP.	1µF 10V Z
C0719	NDC31HJ-470X	C CAP.	47pF 50V J
C0720	NEH71HM-106X	E CAP.	10µF 50V M
C0723	NCB31HK-222X	C CAP.	2200pF 50V K
C0724	NCB31HK-222X	C CAP.	2200pF 50V K
C0729	NEH71HM-106X	E CAP.	10µF 50V M
C0730	NEH71HM-106X	E CAP.	10µF 50V M
C0731	NCB31HK-104X	C CAP.	0.1µF 50V K
C0732	NCB31HK-104X	C CAP.	0.1µF 50V K

COIL

L0101	NQL085J-4R7X	COIL	4.7µH
L0551	NQL085J-4R7X	COIL	4.7µH
L0552	NQL034K-4R7X	COIL	4.7µH
L0701	NQL085J-100X	INDUCTOR	
L0702	NQL085J-100X	INDUCTOR	
L0703	NQL085J-100X	INDUCTOR	

DIODE

D0101	MA111-X	SI. DIODE	
D0102	MA111-X	SI. DIODE	
D0103	MA111-X	SI. DIODE	
D0104	MA111-X	SI. DIODE	
D0201	MA3120/M/-X	ZENER DIODE	
D0301	MA3120/M/-X	ZENER DIODE	
D0401	MA3120/M/-X	ZENER DIODE	
D0701	MA3150/M/-X	ZENER DIODE	
D0702	MA3150/M/-X	ZENER DIODE	
D0703	MA111-X	SI. DIODE	
D0704	MA111-X	SI. DIODE	
D0705	MA111-X	SI. DIODE	
D0706	MA111-X	SI. DIODE	

TRANSISTOR

Q0101	DTC124EKA-X	DIGI. TRANSISTOR	
Q0102	DTC124EKA-X	DIGI. TRANSISTOR	
Q0103	DTC124EKA-X	DIGI. TRANSISTOR	
Q0201	2SK433/D/-W	JUNCTION FET	
Q0301	2SK433/D/-W	JUNCTION FET	
Q0401	DTC124EKA-X	DIGI. TRANSISTOR	
Q0402	DTC124EKA-X	DIGI. TRANSISTOR	
Q0403	2SK433/D/-W	JUNCTION FET	
Q0501	DTC124EKA-X	DIGI. TRANSISTOR	
Q0502	DTC124EKA-X	DIGI. TRANSISTOR	
Q0701	DTC124EKA-X	DIGI. TRANSISTOR	
Q0702	DTC323TK-X	DIGI. TRANSISTOR	

Symbol No.	Part No.	Part Name	Description
TRANSISTOR			
Q0703	DTC323TK-X	DIGI. TRANSISTOR	
Q0704	DTC323TK-X	DIGI. TRANSISTOR	
Q0705	2SA1037AK/QR/-X	SI. TRANSISTOR	
Q0706	2SA1037AK/QR/-X	SI. TRANSISTOR	
Q0707	DTC323TK-X	DIGI. TRANSISTOR	
Q0708	DTC323TK-X	DIGI. TRANSISTOR	
Q0709	2SA1037AK/QR/-X	SI. TRANSISTOR	
Q0710	DTC323TK-X	DIGI. TRANSISTOR	

IC

IC0101	TC9446F-014	IC	
IC0102	TC4066BF/N/-XE	IC	
IC0105	AK4527BVQ	IC	
IC0107	TA48M033F-X	IC	
IC0108	TC7SET32F-X	IC(DIGITAL)	
IC0109	UPD78F4216AGC	I C	
IC0110	S-80828CNB-W	IC	
IC0111	TA48M033F-X	IC	
IC0112	IS63LV1024-15T	IC	
IC0113	TC7WHU04FU-X	IC	
IC0201	BA4558F-X	IC	
IC0202	BA4558F-X	IC	
IC0203	BA4558F-X	IC	
IC0301	BA4558F-X	IC	
IC0302	BA4558F-X	IC	
IC0303	BA4558F-X	IC	
IC0401	TC4066BF/N/-XE	IC	
IC0402	BA4558F-X	IC	
IC0403	BA4558F-X	IC	
IC0404	BA4558F-X	IC	
IC0601	BD3869F-X	IC	
IC0631	BD3869F-X	IC	
IC0651	BD3869F-X	IC	
IC0701	TC4066BF/N/-XE	IC	
IC0702	TC4066BF/N/-XE	IC	
IC0703	BA4558F-X	IC	
IC0704	BA4558F-X	IC	

OTHERS

J0001	QNN0281-004	PIN JACK	
J0002	QNZ0523-001	OPT CONNECTOR	
J0003	QNN0427-001	PIN JACK	
J0004	QNB0006-002	PUSH TERMINAL	
LC0101	NQR0313-009X	EMI FILTER	
LC0102	NQR0313-009X	EMI FILTER	
LC0103	NQR0313-009X	EMI FILTER	
LC0105	NQR0313-009X	EMI FILTER	
LC0106	NQR0313-009X	EMI FILTER	
LC0107	NQR0313-009X	EMI FILTER	
LC0108	NQR0313-009X	EMI FILTER	
LC0109	NQR0313-009X	EMI FILTER	
LC0111	NQR0313-009X	EMI FILTER	
X0101	NAX0385-001X	CRYSTAL	
X0102	NAX0473-001X	C RESONATOR	

■ MICOM P.W. BOARD ASS'Y (SMF-0M403A)

△ Symbol No.	Part No.	Part Name	Description
RESISTOR			
R0001	NRSA63J-102X	MG R	1kΩ 1/16W J
R0002	NRSA63J-104X	MG R	100kΩ 1/16W J
R0003	NRSA63J-102X	MG R	1kΩ 1/16W J
R0004	NRSA63J-102X	MG R	1kΩ 1/16W J
R0005	NRSA63J-102X	MG R	1kΩ 1/16W J
R0006	NRSA63J-152X	MG R	1.5kΩ 1/16W J
R0007	NRSA63J-102X	MG R	1kΩ 1/16W J
R0008	NRSA63J-102X	MG R	1kΩ 1/16W J
R0009	NRSA63J-103X	MG R	10kΩ 1/16W J
R0010	NRSA63J-103X	MG R	10kΩ 1/16W J
R0011	NRSA63J-103X	MG R	10kΩ 1/16W J
R0012	NRSA63J-273X	MG R	27kΩ 1/16W J
R0013	NRSA63J-221X	MG R	220Ω 1/16W J
R0014	NRSA63J-102X	MG R	1kΩ 1/16W J
R0015	NRSA63J-473X	MG R	47kΩ 1/16W J
R0016	NRSA63J-103X	MG R	10kΩ 1/16W J
R0017	NRSA63J-103X	MG R	10kΩ 1/16W J
R0018	NRSA63J-102X	MG R	1kΩ 1/16W J
R0022	NRSA63J-472X	MG R	4.7kΩ 1/16W J
R0027	NRSA63J-472X	MG R	4.7kΩ 1/16W J
R0030	NRSA63J-472X	MG R	4.7kΩ 1/16W J
R0032	NRSA63J-472X	MG R	4.7kΩ 1/16W J
R0034	NRSA63J-0ROX	MG R	0.0Ω 1/16W J
R0035	NRSA63J-0ROX	MG R	0.0Ω 1/16W J
R0036	NRSA63J-0ROX	MG R	0.0Ω 1/16W J
R0037	NRSA63J-0ROX	MG R	0.0Ω 1/16W J
R0038	NRSA63J-0ROX	MG R	0.0Ω 1/16W J
R0039	NRSA63J-0ROX	MG R	0.0Ω 1/16W J
R0040	NRSA63J-0ROX	MG R	0.0Ω 1/16W J
R0041	NRSA63J-0ROX	MG R	0.0Ω 1/16W J
R0042	NRSA63J-0ROX	MG R	0.0Ω 1/16W J
R0043	NRSA63J-0ROX	MG R	0.0Ω 1/16W J
R0044	NRSA63J-0ROX	MG R	0.0Ω 1/16W J
R0045	NRSA63J-0ROX	MG R	0.0Ω 1/16W J
R0046	NRSA63J-0ROX	MG R	0.0Ω 1/16W J
R0047	NRSA63J-0ROX	MG R	0.0Ω 1/16W J
R0048	NRSA63J-0ROX	MG R	0.0Ω 1/16W J
R0049	NRSA63J-0ROX	MG R	0.0Ω 1/16W J
R0050	NRSA63J-0ROX	MG R	0.0Ω 1/16W J
R0051	NRSA63J-0ROX	MG R	0.0Ω 1/16W J
R0052	NRSA63J-0ROX	MG R	0.0Ω 1/16W J
R0053	NRSA63J-0ROX	MG R	0.0Ω 1/16W J
R0055	NRSA63J-0ROX	MG R	0.0Ω 1/16W J
R0057	NRSA63J-0ROX	MG R	0.0Ω 1/16W J
R0058	NRSA63J-0ROX	MG R	0.0Ω 1/16W J
R0059	NRSA63J-0ROX	MG R	0.0Ω 1/16W J
R0060	NRSA63J-0ROX	MG R	0.0Ω 1/16W J
R0061	NRSA63J-0ROX	MG R	0.0Ω 1/16W J
R0062	NRSA63J-0ROX	MG R	0.0Ω 1/16W J
R0063	NRSA63J-0ROX	MG R	0.0Ω 1/16W J
R0064	NRSA63J-0ROX	MG R	0.0Ω 1/16W J
R0065	NRSA63J-0ROX	MG R	0.0Ω 1/16W J
R0066	NRSA63J-0ROX	MG R	0.0Ω 1/16W J
R0067	NRSA63J-0ROX	MG R	0.0Ω 1/16W J
R0068	NRSA63J-0ROX	MG R	0.0Ω 1/16W J
R0069	NRSA63J-0ROX	MG R	0.0Ω 1/16W J
R0070	NRSA63J-0ROX	MG R	0.0Ω 1/16W J
R0071	NRSA63J-0ROX	MG R	0.0Ω 1/16W J
R0072	NRSA63J-0ROX	MG R	0.0Ω 1/16W J
R0073	NRSA63J-0ROX	MG R	0.0Ω 1/16W J
R0074	NRSA63J-0ROX	MG R	0.0Ω 1/16W J
R0075	NRSA63J-0ROX	MG R	0.0Ω 1/16W J
R0076	NRSA63J-0ROX	MG R	0.0Ω 1/16W J
R0077	NRSA63J-0ROX	MG R	0.0Ω 1/16W J
R0081	NCF31CZ-104X	C CAP.	0.1μF 16V Z
R0087	NRSA63J-221X	MG R	220Ω 1/16W J
R0089	NRSA63J-221X	MG R	220Ω 1/16W J
R0090	NRSA63J-221X	MG R	220Ω 1/16W J
R0091	NRSA63J-221X	MG R	220Ω 1/16W J
R0092	NRSA63J-472X	MG R	4.7kΩ 1/16W J
R0093	NRSA63J-221X	MG R	220Ω 1/16W J
R0094	NRSA63J-472X	MG R	4.7kΩ 1/16W J
R0095	NRSA63J-473X	MG R	47kΩ 1/16W J
R0096	NRSA63J-221X	MG R	220Ω 1/16W J
R0097	NRSA63J-102X	MG R	1kΩ 1/16W J
R0098	NRSA63J-0ROX	MG R	0.0Ω 1/16W J
R0099	NRSA63J-102X	MG R	1kΩ 1/16W J
R0100	NRSA63J-102X	MG R	1kΩ 1/16W J
R0101	NRSA63J-102X	MG R	1kΩ 1/16W J

△ Symbol No.	Part No.	Part Name	Description
RESISTOR			
R0102	NRSA63J-102X	MG R	1kΩ 1/16W J
R0103	NRSA63J-103X	MG R	10kΩ 1/16W J
R0104	NRSA63J-103X	MG R	10kΩ 1/16W J
R0105	NRSA63J-103X	MG R	10kΩ 1/16W J
R0106	NRSA63J-103X	MG R	10kΩ 1/16W J
R0107	NRSA63J-102X	MG R	1kΩ 1/16W J
R0110	NRSA63J-102X	MG R	1kΩ 1/16W J
R0111	NRSA63J-103X	MG R	10kΩ 1/16W J
R0112	NRSA63J-102X	MG R	1kΩ 1/16W J
R0113	NRSA63J-103X	MG R	10kΩ 1/16W J
R0114	NRSA63J-103X	MG R	10kΩ 1/16W J
R0119	NRSA63J-563X	MG R	56kΩ 1/16W J
R0120	NRSA63J-332X	MG R	3.3kΩ 1/16W J
R0121	NRSA63J-182X	MG R	1.8kΩ 1/16W J
R0122	NRSA63J-682X	MG R	6.8kΩ 1/16W J
R0123	NRSA63J-682X	MG R	6.8kΩ 1/16W J
R0124	NRSA63J-101X	MG R	100Ω 1/16W J
R0125	NRSA63J-472X	MG R	4.7kΩ 1/16W J
R0126	NRSA63J-472X	MG R	4.7kΩ 1/16W J
R0127	NRSA63J-472X	MG R	4.7kΩ 1/16W J
R0128	NRSA63J-472X	MG R	4.7kΩ 1/16W J
R0129	NRSA63J-823X	MG R	82kΩ 1/16W J
R0130	NRSA63J-104X	MG R	100kΩ 1/16W J
R0131	NRSA63J-0ROX	MG R	0.0Ω 1/16W J
R0133	NRSA63J-0ROX	MG R	0.0Ω 1/16W J
R0136	NRSA63J-103X	MG R	10kΩ 1/16W J
R0137	NRSA63J-222X	MG R	2.2kΩ 1/16W J
R0138	NRSA63J-222X	MG R	2.2kΩ 1/16W J
R0139	NRSA63J-222X	MG R	2.2kΩ 1/16W J
R0144	NRSA63J-103X	MG R	10kΩ 1/16W J
R0147	NRSA63J-472X	MG R	4.7kΩ 1/16W J
R0151	NRSA63J-183X	MG R	18kΩ 1/16W J
R0152	NRSA63J-221X	MG R	220Ω 1/16W J
R0153	NRSA63J-221X	MG R	220Ω 1/16W J
R0154	NRSA63J-221X	MG R	220Ω 1/16W J
R0155	NRSA63J-101X	MG R	100Ω 1/16W J
R0156	NRSA63J-101X	MG R	100Ω 1/16W J
R0157	NRSA63J-0ROX	MG R	0.0Ω 1/16W J
R0158	NRSA63J-221X	MG R	220Ω 1/16W J
R0165	NRSA63J-103X	MG R	10kΩ 1/16W J
R0166	NRSA63J-223X	MG R	22kΩ 1/16W J
R0167	NRSA63J-103X	MG R	10kΩ 1/16W J
R0168	NRSA63J-471X	MG R	470Ω 1/16W J
R0169	NRSA63J-472X	MG R	4.7kΩ 1/16W J

CAPACITOR

C0001	QETNOJM-477Z	E CAP.	470μF 6.3V M
C0002	NCF31CZ-104X	C CAP.	0.1μF 16V Z
C0003	NCB11CK-225X	C CAP.	2.2μF 16V K
C0004	QETNOJM-108Z	E CAP.	1000μF 6.3V M
C0005	NCB11CK-225X	C CAP.	2.2μF 16V K
C0006	NCB11CK-225X	C CAP.	2.2μF 16V K
C0007	NEH71CM-476X	E CAP.	47μF 16V M
C0012	NCF31CZ-104X	C CAP.	0.1μF 16V Z
C0013	NCF31CZ-104X	C CAP.	0.1μF 16V Z
C0014	NCB31HK-682X	C CAP.	6800pF 50V K
C0017	NDC31HJ-220X	C CAP.	22pF 50V J
C0019	NEH71CM-476X	E CAP.	47μF 16V M
C0020	NCF31CZ-104X	C CAP.	0.1μF 16V Z
C0021	NEH71CM-476X	E CAP.	47μF 16V M
C0022	NCF31AZ-105X	C CAP.	1μF 10V Z
C0023	NCB31EK-333X	C CAP.	0.033μF 25V K
C0024	NCF31CZ-104X	C CAP.	0.1μF 16V Z
C0027	NEH71CM-476X	E CAP.	47μF 16V M
C0028	NEH71CM-476X	E CAP.	47μF 16V M
C0029	NDC31HJ-151X	C CAP.	150pF 50V J
C0030	NCF31CZ-104X	C CAP.	0.1μF 16V Z
C0031	NCF31CZ-104X	C CAP.	0.1μF 16V Z
C0032	NCF31CZ-104X	C CAP.	0.1μF 16V Z
C0034	NCF31CZ-104X	C CAP.	0.1μF 16V Z
C0035	NCF31CZ-104X	C CAP.	0.1μF 16V Z
C0036	NCF31CZ-104X	C CAP.	0.1μF 16V Z
C0037	NCF31CZ-104X	C CAP.	0.1μF 16V Z
C0038	NCF31CZ-104X	C CAP.	0.1μF 16V Z
C0039	NCF31CZ-104X	C CAP.	0.1μF 16V Z
C0040	NDC31HJ-330X	C CAP.	33pF 50V J
C0041	NDC31HJ-270X	C CAP.	27pF 50V J
C0042	NCF31CZ-104X	C CAP.	0.1μF 16V Z
C0043	NCF31CZ-104X	C CAP.	0.1μF 16V Z

Symbol No.	Part No.	Part Name	Description
CAPACITOR			
C0045	NCF31CZ-104X	C CAP.	0.1μF 16V Z
C0046	NCF31CZ-104X	C CAP.	0.1μF 16V Z
C0047	NCF31CZ-104X	C CAP.	0.1μF 16V Z
C0048	NEH71CM-476X	E CAP.	47μF 16V M
C0049	NCF31CZ-104X	C CAP.	0.1μF 16V Z
C0050	NCF31CZ-104X	C CAP.	0.1μF 16V Z
C0051	NEH71CM-476X	E CAP.	47μF 16V M
C0052	NCF31CZ-104X	C CAP.	0.1μF 16V Z
C0053	NCF31CZ-104X	C CAP.	0.1μF 16V Z
C0054	NCF31CZ-104X	C CAP.	0.1μF 16V Z
C0055	NCF31CZ-104X	C CAP.	0.1μF 16V Z
C0056	NCF31CZ-104X	C CAP.	0.1μF 16V Z
C0057	NCF31CZ-104X	C CAP.	0.1μF 16V Z
C0059	NEH71CM-106X	E CAP.	10μF 16V M
C0060	NEH71CM-106X	E CAP.	10μF 16V M
C0061	NEH71CM-106X	E CAP.	10μF 16V M
C0062	NRSA63J-0R0X	MG R	0.0Ω 1/16W J
C0063	NDC31HJ-820X	C CAP.	82pF 50V J
C0064	NDC31HJ-820X	C CAP.	82pF 50V J
C0065	NDC31HJ-820X	C CAP.	82pF 50V J

COIL

L0001	NQL092K-4R7X	COIL	4.7μH
L0003	NQL092K-4R7X	COIL	4.7μH
L0005	NQL092K-4R7X	COIL	4.7μH
L0006	NQL092K-4R7X	COIL	4.7μH
L0007	NQL092K-4R7X	COIL	4.7μH
L0008	NQL092K-4R7X	COIL	4.7μH
L0009	NQL034K-4R7X	COIL	4.7μH
L0010	NQL092K-4R7X	COIL	4.7μH
L0011	NQL092K-4R7X	COIL	4.7μH
L0012	NQL092K-4R7X	COIL	4.7μH
L0013	NQL092K-4R7X	COIL	4.7μH
L0014	NQL092K-4R7X	COIL	4.7μH
L0015	NQL034K-4R7X	COIL	4.7μH
L0016	NQL034K-4R7X	COIL	4.7μH
L0017	NQL092K-1R5X	COIL	1.5μH
L0018	NQL092K-1R5X	COIL	1.5μH
L0019	NQL092K-1R5X	COIL	1.5μH
L0020	NQL092K-1R5X	COIL	1.5μH
L0021	NQL092K-1R5X	COIL	1.5μH
L0022	NQL092K-1R5X	COIL	1.5μH

DIODE

D0001	MA111-X	SI. DIODE	
D0002	MA111-X	SI. DIODE	
D0003	MA3068/M/-X	ZENER DIODE	
D0004	MA3027-X	ZENER DIODE	
D0005	MA3056/M/-X	ZENER DIODE	
D0006	MA3056/M/-X	ZENER DIODE	
D0007	MA3056/M/-X	ZENER DIODE	
D0008	MA3056/M/-X	ZENER DIODE	

TRANSISTOR

Q0001	2SC2712/YG/-X	SI. TRANSISTOR	
Q0002	2SC2712/YG/-X	SI. TRANSISTOR	
Q0007	2SA1162/YG/-X	SI. TRANSISTOR	
Q0008	2SA1162/YG/-X	SI. TRANSISTOR	
Q0009	2SC2712/YG/-X	SI. TRANSISTOR	
Q0010	2SC2712/YG/-X	SI. TRANSISTOR	
Q0011	2SC2712/YG/-X	SI. TRANSISTOR	
Q0012	2SC2712/YG/-X	SI. TRANSISTOR	
Q0021	2SC2712/YG/-X	SI. TRANSISTOR	
Q0022	2SC2712/YG/-X	SI. TRANSISTOR	

IC

IC0001	SDA6000	IC	
IC0002	MR27V16S2EE5RAZ	IC(MICRO C ROM)	
IC0003	K45161622D-TC80	IC	
IC0004	AT24LC-28Z25EU	IC	(SERVICE)
IC0005	S-80828CNB-W	IC	
IC0901	BA33C25FP-X	IC	

OTHERS

K0001	NRSA63J-390X	MG R	39Ω 1/16W J
K0002	NQR0389-003X	FERRITE BEADS	
K0003	NRSA63J-0R0X	MG R	0.0Ω 1/16W J
K0004	NQR0389-003X	FERRITE BEADS	

Symbol No.	Part No.	Part Name	Description
OTHERS			
K0005	NRSA63J-0R0X	MG R	0.0Ω 1/16W J
LC0001	NQR0313-007X	EMI FILTER	
LC0002	NQR0431-001X	EMI FILTER	
X0001	QAX0669-001Z	CRYSTAL	

AV SW P.W. BOARD ASS'Y (SMF-0S402A)

Symbol No.	Part No.	Part Name	Description
RESISTOR			
R0101	NRSA63J-750X	MG R	75Ω 1/16W J
R0102	NRSA63J-750X	MG R	75Ω 1/16W J
R0103	NRSA63J-750X	MG R	75Ω 1/16W J
R0104	NRSA63J-750X	MG R	75Ω 1/16W J
R0105	NRSA63J-750X	MG R	75Ω 1/16W J
R0106	NRSA63J-750X	MG R	75Ω 1/16W J
R0107	NRSA63J-750X	MG R	75Ω 1/16W J
R0108	NRSA63J-750X	MG R	75Ω 1/16W J
R0109	NRSA63J-750X	MG R	75Ω 1/16W J
R0110	NRSA63J-103X	MG R	10kΩ 1/16W J
R0111	NRSA63J-103X	MG R	10kΩ 1/16W J
R0112	NRSA63J-823X	MG R	82kΩ 1/16W J
R0113	NRSA63J-823X	MG R	82kΩ 1/16W J
R0114	NRSA63J-333X	MG R	33kΩ 1/16W J
R0115	NRSA63J-473X	MG R	47kΩ 1/16W J
R0116	NRSA63J-823X	MG R	82kΩ 1/16W J
R0117	NRSA63J-223X	MG R	22kΩ 1/16W J
R0118	NRSA63J-473X	MG R	47kΩ 1/16W J
R0119	NRSA63J-153X	MG R	15kΩ 1/16W J
R0120	NRSA63J-273X	MG R	27kΩ 1/16W J
R0121	NRSA63J-222X	MG R	2.2kΩ 1/16W J
R0122	NRSA63J-473X	MG R	47kΩ 1/16W J
R0123	NRSA63J-823X	MG R	82kΩ 1/16W J
R0124	NRSA63J-153X	MG R	15kΩ 1/16W J
R0125	NRSA63J-223X	MG R	22kΩ 1/16W J
R0126	NRSA63J-473X	MG R	47kΩ 1/16W J
R0127	NRSA63J-273X	MG R	27kΩ 1/16W J
R0128	NRSA63J-823X	MG R	82kΩ 1/16W J
R0129	NRSA63J-823X	MG R	82kΩ 1/16W J
R0130	NRSA63J-391X	MG R	390Ω 1/16W J
R0131	NRSA63J-391X	MG R	390Ω 1/16W J
R0132	NRSA63J-222X	MG R	2.2kΩ 1/16W J
R0133	NRSA63J-333X	MG R	33kΩ 1/16W J
R0134	NRSA63J-222X	MG R	2.2kΩ 1/16W J
R0135	NRSA63J-333X	MG R	33kΩ 1/16W J
R0136	NRSA63J-103X	MG R	10kΩ 1/16W J
R0137	NRSA63J-222X	MG R	2.2kΩ 1/16W J
R0138	NRSA63J-333X	MG R	33kΩ 1/16W J
R0139	NRSA63J-333X	MG R	33kΩ 1/16W J
R0140	NRSA63J-222X	MG R	2.2kΩ 1/16W J
R0141	NRSA63J-333X	MG R	33kΩ 1/16W J
R0142	NRSA63J-222X	MG R	2.2kΩ 1/16W J
R0143	NRSA63J-333X	MG R	33kΩ 1/16W J
R0144	NRSA63J-333X	MG R	33kΩ 1/16W J
R0145	NRSA63J-103X	MG R	10kΩ 1/16W J
R0146	NRSA63J-473X	MG R	47kΩ 1/16W J
R0147	NRSA63J-223X	MG R	22kΩ 1/16W J
R0148	NRSA63J-391X	MG R	390Ω 1/16W J
R0149	NRSA63J-391X	MG R	390Ω 1/16W J
R0150	NRSA63J-104X	MG R	100kΩ 1/16W J
R0151	NRSA63J-104X	MG R	100kΩ 1/16W J
R0152	NRSA63J-101X	MG R	100Ω 1/16W J
R0153	NRSA63J-101X	MG R	100Ω 1/16W J
R0154	NRSA63J-101X	MG R	100Ω 1/16W J
R0155	NRSA63J-101X	MG R	100Ω 1/16W J
R0156	NRSA63J-101X	MG R	100Ω 1/16W J
R0157	NRSA63J-101X	MG R	100Ω 1/16W J
R0158	NRSA63J-101X	MG R	100Ω 1/16W J
R0159	NRSA63J-101X	MG R	100Ω 1/16W J
R0160	NRSA63J-101X	MG R	100Ω 1/16W J
R0161	NRSA63J-101X	MG R	100Ω 1/16W J

Symbol No.	Part No.	Part Name	Description
RESISTOR			
R0162	NRSA63J-101X	MG R	100Ω 1/16W J
R0163	NRSA63J-101X	MG R	100Ω 1/16W J
R0164	NRSA63J-101X	MG R	100Ω 1/16W J
R0165	NRSA63J-101X	MG R	100Ω 1/16W J
R0166	NRSA63J-101X	MG R	100Ω 1/16W J
R0167	NRSA63J-101X	MG R	100Ω 1/16W J
R0168	NRSA63J-750X	MG R	75Ω 1/16W J
R0169	NRSA63J-222X	MG R	2.2kΩ 1/16W J
R0170	NRSA63J-333X	MG R	33kΩ 1/16W J
R0171	NRSA63J-750X	MG R	75Ω 1/16W J
R0172	NRSA63J-222X	MG R	2.2kΩ 1/16W J
R0173	NRSA63J-333X	MG R	33kΩ 1/16W J
R0174	NRSA63J-750X	MG R	75Ω 1/16W J
R0175	NRSA63J-333X	MG R	33kΩ 1/16W J
R0176	NRSA63J-103X	MG R	10kΩ 1/16W J
R0177	NRSA63J-823X	MG R	82kΩ 1/16W J
R0178	NRSA63J-153X	MG R	15kΩ 1/16W J
R0179	NRSA63J-473X	MG R	47kΩ 1/16W J
R0180	NRSA63J-273X	MG R	27kΩ 1/16W J
R0181	NRSA63J-562X	MG R	5.6kΩ 1/16W J
R0182	NRSA63J-562X	MG R	5.6kΩ 1/16W J
R0183	NRSA63J-102X	MG R	1kΩ 1/16W J
R0184	NRSA63J-102X	MG R	1kΩ 1/16W J
R0185	NRSA63J-101X	MG R	100Ω 1/16W J
R0186	NRSA63J-101X	MG R	100Ω 1/16W J
R0187	NRSA63J-101X	MG R	100Ω 1/16W J
R0188	NRSA63J-101X	MG R	100Ω 1/16W J
R0189	NRSA63J-101X	MG R	100Ω 1/16W J
R0190	NRSA63J-101X	MG R	100Ω 1/16W J
R0191	NRSA63J-222X	MG R	2.2kΩ 1/16W J
R0192	NRSA63J-101X	MG R	100Ω 1/16W J
R0194	NRSA63J-221X	MG R	220Ω 1/16W J
R0195	NRSA63J-221X	MG R	220Ω 1/16W J
R0196	QRG01GJ-101	OM R	100Ω 1W J
R0197	QRK126J-181X	C R	180Ω 1/2W J
R0198	NRSA63J-750X	MG R	75Ω 1/16W J
R0199	NRSA63J-101X	MG R	100Ω 1/16W J
R0200	NRSA63J-750X	MG R	75Ω 1/16W J
R0201	QRK126J-151X	C R	150Ω 1/2W J
R0203	NRSA63J-750X	MG R	75Ω 1/16W J
R0204	NRSA63J-750X	MG R	75Ω 1/16W J
R0205	NRSA63J-750X	MG R	75Ω 1/16W J

CAPACITOR

C0101	NCB31HK-472X	C CAP.	4700pF 50V K
C0102	NCB31HK-472X	C CAP.	4700pF 50V K
C0103	NCB31HK-472X	C CAP.	4700pF 50V K
C0104	NCB31HK-472X	C CAP.	4700pF 50V K
C0105	NCB31HK-472X	C CAP.	4700pF 50V K
C0106	NCB31HK-472X	C CAP.	4700pF 50V K
C0107	NCB31HK-472X	C CAP.	4700pF 50V K
C0108	NCB31HK-472X	C CAP.	4700pF 50V K
C0109	NCB31HK-472X	C CAP.	4700pF 50V K
C0110	NCB31HK-472X	C CAP.	4700pF 50V K
C0111	QETN1CM-477Z	E CAP.	470μF 16V M
C0112	QETN1CM-477Z	E CAP.	470μF 16V M
C0113	NCB31HK-102X	C CAP.	1000pF 50V K
C0114	NCB31HK-102X	C CAP.	1000pF 50V K
C0115	QETN1HM-106Z	E CAP.	10μF 50V M
C0116	QETN1HM-106Z	E CAP.	10μF 50V M
C0117	QETN1HM-106Z	E CAP.	10μF 50V M
C0118	QETN1HM-105Z	E CAP.	1μF 50V M
C0119	QETN1HM-105Z	E CAP.	1μF 50V M
C0120	NCB31HK-103X	C CAP.	0.01μF 50V K
C0121	QETN1HM-105Z	E CAP.	1μF 50V M
C0122	QETN1HM-106Z	E CAP.	10μF 50V M
C0123	QETN1HM-105Z	E CAP.	1μF 50V M
C0124	NCB31HK-103X	C CAP.	0.01μF 50V K
C0125	NCB31HK-102X	C CAP.	1000pF 50V K
C0126	QETN1HM-106Z	E CAP.	10μF 50V M
C0127	QETN1HM-106Z	E CAP.	10μF 50V M
C0128	QETN1HM-106Z	E CAP.	10μF 50V M
C0129	QETN1HM-105Z	E CAP.	1μF 50V M
C0130	NCB31HK-103X	C CAP.	0.01μF 50V K
C0131	QETN1HM-105Z	E CAP.	1μF 50V M
C0132	NCB31HK-103X	C CAP.	0.01μF 50V K
C0133	QETN1HM-106Z	E CAP.	10μF 50V M
C0134	QETN1HM-105Z	E CAP.	1μF 50V M
C0135	QETN1HM-106Z	E CAP.	10μF 50V M

Symbol No.	Part No.	Part Name	Description
CAPACITOR			
C0136	QETN1HM-105Z	E CAP.	1μF 50V M
C0137	NCB31HK-103X	C CAP.	0.01μF 50V K
C0138	QENC1HM-105Z	E CAP.	1μF 50V M
C0139	QENC1HM-105Z	E CAP.	1μF 50V M
C0140	QENC1EM-106Z	BP E CAP.	10μF 25V M
C0141	NCB31HK-103X	C CAP.	0.01μF 50V K
C0142	NCB31HK-103X	C CAP.	0.01μF 50V K
C0143	NCB31HK-103X	C CAP.	0.01μF 50V K
C0144	NCB31HK-103X	C CAP.	0.01μF 50V K
C0145	NCB31HK-103X	C CAP.	0.01μF 50V K
C0146	NCB31HK-103X	C CAP.	0.01μF 50V K
C0147	NCB31HK-103X	C CAP.	0.01μF 50V K
C0148	QETN1HM-106Z	E CAP.	10μF 50V M
C0149	QENC1EM-106Z	BP E CAP.	10μF 25V M
C0150	QETN1CM-107Z	E CAP.	100μF 16V M
C0151	QETN1CM-107Z	E CAP.	100μF 16V M
C0152	QETN1CM-477Z	E CAP.	470μF 16V M
C0153	NCB31HK-103X	C CAP.	0.01μF 50V K
C0154	QETN1CM-107Z	E CAP.	100μF 16V M
C0155	NDC31HJ-150X	C CAP.	15pF 50V J

COIL

L0101	QQR0716-001Z	FERRITE BEADS
-------	--------------	---------------

DIODE

D0101	MA3056/M/-X	ZENER DIODE
D0102	MA3056/M/-X	ZENER DIODE
D0103	MA3056/M/-X	ZENER DIODE
D0104	MA3056/M/-X	ZENER DIODE
D0109	MA3120/M/-X	ZENER DIODE
D0110	MA3120/M/-X	ZENER DIODE
D0111	MA3120/M/-X	ZENER DIODE
D0112	MA3120/M/-X	ZENER DIODE
D0113	MA3120/M/-X	ZENER DIODE
D0114	MA3039/H/-X	ZENER DIODE
D0115	MA3056/M/-X	ZENER DIODE
D0116	MA3056/M/-X	ZENER DIODE
D0117	MA3056/M/-X	ZENER DIODE

TRANSISTOR

Q0101	2SC2412K/QR/-X	SI. TRANSISTOR
Q0102	2SC2412K/QR/-X	SI. TRANSISTOR
Q0103	DTC323TK-X	DIGI. TRANSISTOR
Q0104	DTC323TK-X	DIGI. TRANSISTOR
Q0105	DTC323TK-X	DIGI. TRANSISTOR
Q0106	2SC2412K/QR/-X	SI. TRANSISTOR
Q0107	2SC2412K/QR/-X	SI. TRANSISTOR
Q0108	2SC2412K/QR/-X	SI. TRANSISTOR
Q0109	2SC2412K/QR/-X	SI. TRANSISTOR
Q0110	2SA1037AK/QR/-X	SI. TRANSISTOR
Q0111	DTC323TK-X	DIGI. TRANSISTOR
Q0112	2SA1037AK/QR/-X	SI. TRANSISTOR
Q0113	2SC2412K/QR/-X	SI. TRANSISTOR
Q0114	2SC2412K/QR/-X	SI. TRANSISTOR
Q0115	2SC2412K/QR/-X	SI. TRANSISTOR
Q0116	2SA933AS/QR/-T	SI. TRANSISTOR
Q0117	2SC1740S/QR/-T	SI. TRANSISTOR

IC

IC0101	CXA2069Q	IC
--------	----------	----

OTHERS

J0001	QNZ0465-001	21P CONNECTOR
J0002	QNZ0463-001	21P CONNECTOR
K0101	CE42681-001Y	CHIP BEADS CORE
K0102	CE42681-001Y	CHIP BEADS CORE
K0103	CE42681-001Y	CHIP BEADS CORE
K0104	CE42681-001Y	CHIP BEADS CORE

■ 100Hz P.W. BOARD ASS'Y (SMF-0Z404A)

△ Symbol No. Part No. Part Name Description

RESISTOR

R0008	NRSA63J-0R0X	MG R	0.0Ω 1/16W J
R0009	NRSA63J-0R0X	MG R	0.0Ω 1/16W J
R0010	NRSA63J-101X	MG R	100Ω 1/16W J
R0011	NRSA63J-101X	MG R	100Ω 1/16W J
R0012	NRSA63J-101X	MG R	100Ω 1/16W J
R0101	NRSA63J-332X	MG R	3.3kΩ 1/16W J
R0102	NRSA63J-222X	MG R	2.2kΩ 1/16W J
R0103	NRSA63J-222X	MG R	2.2kΩ 1/16W J
R0104	NRSA63J-332X	MG R	3.3kΩ 1/16W J
R0105	NRSA63J-222X	MG R	2.2kΩ 1/16W J
R0106	NRSA63J-222X	MG R	2.2kΩ 1/16W J
R0107	NRSA63J-750X	MG R	75Ω 1/16W J
R0108	NRSA63J-750X	MG R	75Ω 1/16W J
R0109	NRSA63J-750X	MG R	75Ω 1/16W J
R0110	NRSA63J-750X	MG R	75Ω 1/16W J
R0111	NRSA63J-750X	MG R	75Ω 1/16W J
R0112	NRSA63J-750X	MG R	75Ω 1/16W J
R0113	NRSA63J-750X	MG R	75Ω 1/16W J
R0122	NRSA63J-0R0X	MG R	0.0Ω 1/16W J
R0123	NRSA63J-0R0X	MG R	0.0Ω 1/16W J
R0124	NRSA63J-101X	MG R	100Ω 1/16W J
R0125	NRSA63J-101X	MG R	100Ω 1/16W J
R0132	NRSA63J-100X	MG R	10Ω 1/16W J
R0133	NRSA63J-100X	MG R	10Ω 1/16W J
R0134	NRSA63J-100X	MG R	10Ω 1/16W J
R0135	NRSA63J-100X	MG R	10Ω 1/16W J
R0136	NRSA63J-100X	MG R	10Ω 1/16W J
R0137	NRSA63J-100X	MG R	10Ω 1/16W J
R0138	NRSA63J-100X	MG R	10Ω 1/16W J
R0139	NRSA63J-100X	MG R	10Ω 1/16W J
R0141	NRSA63J-100X	MG R	10Ω 1/16W J
R0201	NRSA63J-121X	MG R	120Ω 1/16W J
R0202	NRSA63J-101X	MG R	100Ω 1/16W J
R0203	NRSA63J-101X	MG R	100Ω 1/16W J
R0204	NRSA63J-221X	MG R	220Ω 1/16W J
R0205	NRSA63J-0R0X	MG R	0.0Ω 1/16W J
R0214	NRSA63J-0R0X	MG R	0.0Ω 1/16W J
R0217	NRSA63J-103X	MG R	10kΩ 1/16W J
R0218	NRSA63J-333X	MG R	33kΩ 1/16W J
R0219	NRSA63J-103X	MG R	10kΩ 1/16W J
R0220	NRSA63J-822X	MG R	8.2kΩ 1/16W J
R0251	NRSA63J-222X	MG R	2.2kΩ 1/16W J
R0252	NRSA63J-750X	MG R	75Ω 1/16W J
R0254	NRSA63J-391X	MG R	390Ω 1/16W J
R0255	NRSA63J-221X	MG R	220Ω 1/16W J
R0256	NRSA63J-221X	MG R	220Ω 1/16W J
R0257	NRSA63J-271X	MG R	270Ω 1/16W J
R0258	NRSA63J-272X	MG R	2.7kΩ 1/16W J
R0259	NRSA63J-472X	MG R	4.7kΩ 1/16W J
R0261	NRSA63J-222X	MG R	2.2kΩ 1/16W J
R0264	NRSA63J-391X	MG R	390Ω 1/16W J
R0271	NRSA63J-222X	MG R	2.2kΩ 1/16W J
R0274	NRSA63J-391X	MG R	390Ω 1/16W J
R0293	NRSA63J-102X	MG R	1kΩ 1/16W J
R0301	NRSA63J-104X	MG R	100kΩ 1/16W J
R0302	NRSA63J-104X	MG R	100kΩ 1/16W J
R0303	NRSA63J-104X	MG R	100kΩ 1/16W J
R0304	NRSA63J-101X	MG R	100Ω 1/16W J
R0305	NRSA63J-101X	MG R	100Ω 1/16W J
R0306	NRSA63J-152X	MG R	1.5kΩ 1/16W J
R0307	NRSA63J-152X	MG R	1.5kΩ 1/16W J
R0308	NRSA63J-152X	MG R	1.5kΩ 1/16W J
R0401	NRSA63J-473X	MG R	47kΩ 1/16W J
R0402	NRSA63J-472X	MG R	4.7kΩ 1/16W J
R0404	NRSA63J-0R0X	MG R	0.0Ω 1/16W J
R0407	NRSA63J-0R0X	MG R	0.0Ω 1/16W J
R0409	NRSA63J-0R0X	MG R	0.0Ω 1/16W J

CAPACITOR

C0001	NCB31CK-104X	C CAP.	0.1μF 16V K
C0002	NEH71CM-476X	E CAP.	47μF 16V M
C0003	NCB31CK-104X	C CAP.	0.1μF 16V K
C0004	NEH71CM-476X	E CAP.	47μF 16V M
C0005	NCB31CK-104X	C CAP.	0.1μF 16V K
C0006	NEH71CM-476X	E CAP.	47μF 16V M
C0007	NDC31HJ-4R0X	C CAP.	4.0pF 50V J
C0008	NDC31HJ-4R0X	C CAP.	4.0pF 50V J
C0009	NDC31HJ-4R0X	C CAP.	4.0pF 50V J
C0101	NEH71CM-106X	E CAP.	10μF 16V M

△ Symbol No. Part No. Part Name Description

CAPACITOR

C0102	NCB31EK-473X	C CAP.	0.047μF 25V K
C0103	NEH71CM-476X	E CAP.	47μF 16V M
C0104	NCB31HK-152X	C CAP.	1500pF 50V K
C0105	NDC31HJ-102X	C CAP.	1000pF 50V J
C0106	NCB31CK-104X	C CAP.	0.1μF 16V K
C0107	NCF31CZ-224X	C CAP.	0.22μF 16V Z
C0108	NCB31HK-152X	C CAP.	1500pF 50V K
C0109	NDC31HJ-391X	C CAP.	390pF 50V J
C0110	NEH71CM-106X	E CAP.	10μF 16V M
C0111	NCB31EK-473X	C CAP.	0.047μF 25V K
C0112	NDC31HJ-331X	C CAP.	330pF 50V J
C0113	NCF31CZ-224X	C CAP.	0.22μF 16V Z
C0114	NCF31CZ-224X	C CAP.	0.22μF 16V Z
C0115	NCF31CZ-224X	C CAP.	0.22μF 16V Z
C0116	NCF31CZ-224X	C CAP.	0.22μF 16V Z
C0117	NCF31CZ-224X	C CAP.	0.22μF 16V Z
C0118	NCF31CZ-224X	C CAP.	0.22μF 16V Z
C0119	NDC31HJ-331X	C CAP.	330pF 50V J
C0120	NDC31HJ-331X	C CAP.	330pF 50V J
C0121	NDC31HJ-331X	C CAP.	330pF 50V J
C0122	NDC31HJ-331X	C CAP.	330pF 50V J
C0123	NDC31HJ-331X	C CAP.	330pF 50V J
C0124	NDC31HJ-331X	C CAP.	330pF 50V J
C0125	NDC31HJ-3R0X	C CAP.	3.0pF 50V J
C0126	NDC31HJ-3R0X	C CAP.	3.0pF 50V J
C0128	NCB31CK-104X	C CAP.	0.1μF 16V K
C0129	NCF31CZ-224X	C CAP.	0.22μF 16V Z
C0130	NDC31HJ-391X	C CAP.	390pF 50V J
C0131	NCB31HK-152X	C CAP.	1500pF 50V K
C0132	NCB31EK-473X	C CAP.	0.047μF 25V K
C0133	NCB31HK-152X	C CAP.	1500pF 50V K
C0134	NCB31CK-683X	C CAP.	0.068μF 16V K
C0136	NCB31CK-683X	C CAP.	0.068μF 16V K
C0137	NCB31CK-683X	C CAP.	0.068μF 16V K
C0138	NCB31HK-152X	C CAP.	1500pF 50V K
C0139	NCB31EK-473X	C CAP.	0.047μF 25V K
C0140	NEH71CM-476X	E CAP.	47μF 16V M
C0141	NDC31HJ-100X	C CAP.	10pF 50V J
C0201	NEH71CM-476X	E CAP.	47μF 16V M
C0202	NCB31CK-104X	C CAP.	0.1μF 16V K
C0203	NCB31CK-104X	C CAP.	0.1μF 16V K
C0204	NCB31CK-104X	C CAP.	0.1μF 16V K
C0205	NCB31CK-104X	C CAP.	0.1μF 16V K
C0206	NEH71CM-476X	E CAP.	47μF 16V M
C0207	NCB31CK-104X	C CAP.	0.1μF 16V K
C0208	NCB31CK-104X	C CAP.	0.1μF 16V K
C0209	NCB31CK-104X	C CAP.	0.1μF 16V K
C0210	NCB31CK-104X	C CAP.	0.1μF 16V K
C0211	NCB31CK-104X	C CAP.	0.1μF 16V K
C0212	NDC31HJ-180X	C CAP.	18pF 50V J
C0213	NDC31HJ-180X	C CAP.	18pF 50V J
C0214	NCB31CK-104X	C CAP.	0.1μF 16V K
C0215	NCB31CK-104X	C CAP.	0.1μF 16V K
C0216	NCB31CK-104X	C CAP.	0.1μF 16V K
C0217	NCB31CK-104X	C CAP.	0.1μF 16V K
C0218	NDC31HJ-561X	C CAP.	560pF 50V J
C0219	NEH71CM-476X	E CAP.	47μF 16V M
C0220	NCB31CK-104X	C CAP.	0.1μF 16V K
C0221	NCB31CK-104X	C CAP.	0.1μF 16V K
C0222	NCB31CK-104X	C CAP.	0.1μF 16V K
C0223	NCB31CK-104X	C CAP.	0.1μF 16V K
C0224	NCB31CK-104X	C CAP.	0.1μF 16V K
C0225	NCB31CK-104X	C CAP.	0.1μF 16V K
C0226	NCB31CK-104X	C CAP.	0.1μF 16V K
C0227	NCB31CK-104X	C CAP.	0.1μF 16V K
C0228	NCB31CK-104X	C CAP.	0.1μF 16V K
C0229	NCB31CK-104X	C CAP.	0.1μF 16V K
C0231	NCB31CK-104X	C CAP.	0.1μF 16V K
C0232	NCB31CK-104X	C CAP.	0.1μF 16V K
C0233	NCB31CK-104X	C CAP.	0.1μF 16V K
C0234	NCB31CK-104X	C CAP.	0.1μF 16V K
C0235	NCB31CK-104X	C CAP.	0.1μF 16V K
C0237	NEH71CM-106X	E CAP.	10μF 16V M
C0238	NEH71CM-106X	E CAP.	10μF 16V M
C0239	NCB31CK-104X	C CAP.	0.1μF 16V K
C0240	NCB31CK-104X	C CAP.	0.1μF 16V K
C0241	NCB31CK-104X	C CAP.	0.1μF 16V K
C0242	NCB31CK-104X	C CAP.	0.1μF 16V K
C0251	NDC31HJ-4R0X	C CAP.	4.0pF 50V J
C0252	NCB31CK-104X	C CAP.	0.1μF 16V K
C0253	NCB31CK-104X	C CAP.	0.1μF 16V K

△ Symbol No.	Part No.	Part Name	Description
CAPACITOR			
C0254	NDC31HJ-120X	C CAP.	12pF 50V J
C0255	NDC31HJ-270X	C CAP.	27pF 50V J
C0256	NEH71CM-106X	E CAP.	10μF 16V M
C0261	NDC31HJ-4R0X	C CAP.	4.0pF 50V J
C0262	NCB31CK-104X	C CAP.	0.1μF 16V K
C0263	NCB31CK-104X	C CAP.	0.1μF 16V K
C0264	NDC31HJ-120X	C CAP.	12pF 50V J
C0265	NDC31HJ-270X	C CAP.	27pF 50V J
C0271	NDC31HJ-4R0X	C CAP.	4.0pF 50V J
C0272	NCB31CK-104X	C CAP.	0.1μF 16V K
C0273	NCB31CK-104X	C CAP.	0.1μF 16V K
C0274	NDC31HJ-120X	C CAP.	12pF 50V J
C0275	NDC31HJ-270X	C CAP.	27pF 50V J
C0281	NCF31AZ-105X	C CAP.	1μF 10V Z
C0282	NEH71CM-476X	E CAP.	47μF 16V M
C0283	NCB31CK-104X	C CAP.	0.1μF 16V K
C0284	NCB31CK-104X	C CAP.	0.1μF 16V K
C0285	NCB31CK-104X	C CAP.	0.1μF 16V K
C0286	NEH71CM-106X	E CAP.	10μF 16V M
C0301	NEH71CM-476X	E CAP.	47μF 16V M
C0302	NCB31CK-104X	C CAP.	0.1μF 16V K
C0303	NCB31CK-104X	C CAP.	0.1μF 16V K
C0402	NCB31CK-104X	C CAP.	0.1μF 16V K
C0403	NCB31CK-104X	C CAP.	0.1μF 16V K
C0404	NDC31HJ-330X	C CAP.	33pF 50V J
COIL			
L0001	NQL092K-1R5X	COIL	1.5μH
L0002	NQL092K-1R5X	COIL	1.5μH
L0003	NQL092K-1R5X	COIL	1.5μH
L0101	NQL034K-150X	COIL	15μH
L0102	NQL092K-3R3X	COIL	3.3μH
L0103	NQL092K-3R3X	COIL	3.3μH
L0104	NQL092K-3R3X	COIL	3.3μH
L0105	NQL092K-3R3X	COIL	3.3μH
L0106	NQL092K-3R3X	COIL	3.3μH
L0107	NQL092K-3R3X	COIL	3.3μH
L0108	NQL092K-3R3X	COIL	3.3μH
L0109	NQL034K-6R8X	COIL	6.8μH
L0201	NQL034K-100X	COIL	10μH
L0202	NQL034K-100X	COIL	10μH
L0203	NQL034K-100X	COIL	10μH
L0204	NQL034K-100X	COIL	10μH
L0205	NQL034K-100X	COIL	10μH
L0207	NQL034K-100X	COIL	10μH
L0208	NQL034K-100X	COIL	10μH
L0209	NQL092K-1R5X	COIL	1.5μH
L0210	NQL092K-1R5X	COIL	1.5μH
L0211	NQR0413-003X	FERRITE BEADS	
L0251	NQL092K-5R6X	COIL	5.6μH
L0261	NQL092K-5R6X	COIL	5.6μH
L0271	NQL092K-5R6X	COIL	5.6μH
DIODE			
D0401	MA111-X	SI.DIODE	
TRANSISTOR			
Q0101	2SA1037AK/QR/-X	SI.TRANSISTOR	
Q0102	2SA1037AK/QR/-X	SI.TRANSISTOR	
Q0201	2SA1037AK/QR/-X	SI.TRANSISTOR	
Q0251	2SA1037AK/QR/-X	SI.TRANSISTOR	
Q0252	2SA1037AK/QR/-X	SI.TRANSISTOR	
Q0253	2SC2412K/QR/-X	SI.TRANSISTOR	
Q0261	2SA1037AK/QR/-X	SI.TRANSISTOR	
Q0271	2SA1037AK/QR/-X	SI.TRANSISTOR	
Q0301	2SC2412K/QR/-X	SI.TRANSISTOR	
Q0302	2SC2412K/QR/-X	SI.TRANSISTOR	
Q0303	2SC2412K/QR/-X	SI.TRANSISTOR	
IC			
IC0101	VPC3230D-QA-B3	IC	
IC0201	SAA4979H/V105	IC	
IC0202	SAA4994H/V1	IC	
IC0203	SAA4955HL/V1	IC	
IC0212	R1170H251B-X	IC	
IC0213	TC7WH32FK-X	IC	
IC0301	TDA9178T/N1-X	IC	
IC0401	S-80828CNB-W	IC	
IC0402	TC7WH34FU-X	IC	

△ Symbol No.	Part No.	Part Name	Description
OTHERS			
LC0010	NQR0313-009X	EMI FILTER	
LC0011	NQR0313-009X	EMI FILTER	
LC0012	NQR0313-009X	EMI FILTER	
LC0013	NQR0313-004X	EMI FILTER	
LC0014	NQR0313-007X	EMI FILTER	
LC0015	NQR0313-007X	EMI FILTER	
X0101	QAX0655-001Z	CRYSTAL	
X0201	QAX0273-001Z	CRYSTAL	

[AV-28Z25EUY]

PRINTED WIRING BOARD PARTS LIST

■ MAIN P.W. BOARD ASS'Y (SMF-1405A)

△ Symbol No.	Part No.	Part Name	Description
RESISTOR			
R1004	NRSA63J-101X	MG R	100Ω 1/16W J
R1005	NRSA63J-101X	MG R	100Ω 1/16W J
R1006	NRSA63J-101X	MG R	100Ω 1/16W J
R1008	NRSA63J-101X	MG R	100Ω 1/16W J
R1009	NRSA63J-0R0X	MG R	0.0Ω 1/16W J
R1102	NRSA63J-0R0X	MG R	0.0Ω 1/16W J
R1103	NRSA63J-222X	MG R	2.2kΩ 1/16W J
R1104	NRSA63J-102X	MG R	1kΩ 1/16W J
R1105	NRSA63J-561X	MG R	560Ω 1/16W J
R1106	NRSA63J-331X	MG R	330Ω 1/16W J
R1108	NRSA63J-102X	MG R	1kΩ 1/16W J
R1109	NRSA63J-101X	MG R	100Ω 1/16W J
R1110	NRSA63J-101X	MG R	100Ω 1/16W J
R1111	NRSA63J-101X	MG R	100Ω 1/16W J
R1151	NRSA63J-101X	MG R	100Ω 1/16W J
R1153	NRSA63J-101X	MG R	100Ω 1/16W J
R1301	NRSA63J-101X	MG R	100Ω 1/16W J
R1302	NRSA63J-101X	MG R	100Ω 1/16W J
R1303	NRSA63J-273X	MG R	27kΩ 1/16W J
R1304	NRSA63J-102X	MG R	1kΩ 1/16W J
R1311	NRSA63J-331X	MG R	330Ω 1/16W J
R1312	NRSA63J-273X	MG R	27kΩ 1/16W J
R1313	NRSA63J-183X	MG R	18kΩ 1/16W J
R1314	NRSA63J-221X	MG R	220Ω 1/16W J
R1315	NRSA63J-101X	MG R	100Ω 1/16W J
R1316	NRSA63J-101X	MG R	100Ω 1/16W J
R1317	NRSA63J-101X	MG R	100Ω 1/16W J
R1318	NRSA63J-562X	MG R	5.6kΩ 1/16W J
R1319	NRSA63J-183X	MG R	18kΩ 1/16W J
R1321	NRSA63J-0R0X	MG R	0.0Ω 1/16W J
R1322	NRSA63J-0R0X	MG R	0.0Ω 1/16W J
R1325	NRSA63J-101X	MG R	100Ω 1/16W J
R1326	NRSA63J-682X	MG R	6.8kΩ 1/16W J
R1401	NRSA63J-102X	MG R	1kΩ 1/16W J
R1402	NRSA63J-102X	MG R	1kΩ 1/16W J
R1403	NRSA63J-331X	MG R	330Ω 1/16W J
R1404	NRSA63J-331X	MG R	330Ω 1/16W J
R1405	NRSA63J-102X	MG R	1kΩ 1/16W J
R1406	NRSA63J-102X	MG R	1kΩ 1/16W J
R1451	NRSA63J-821X	MG R	820Ω 1/16W J
R1454	NRSA63J-472X	MG R	4.7kΩ 1/16W J
R1455	NRSA63J-123X	MG R	12kΩ 1/16W J
R1456	NRSA63J-123X	MG R	12kΩ 1/16W J
R1457	NRSA63J-392X	MG R	3.9kΩ 1/16W J
R1458	NRSA63J-123X	MG R	12kΩ 1/16W J
R1459	NRSA63J-472X	MG R	4.7kΩ 1/16W J
R1461	NRSA63J-123X	MG R	12kΩ 1/16W J
R1462	NRSA63J-153X	MG R	15kΩ 1/16W J
R1463	NRSA63J-104X	MG R	100kΩ 1/16W J
R1465	NRSA63J-224X	MG R	220kΩ 1/16W J
R1466	NRSA63J-224X	MG R	220kΩ 1/16W J
R1467	NRSA63J-563X	MG R	56kΩ 1/16W J
R1468	NRSA63J-224X	MG R	220kΩ 1/16W J
R1469	NRSA63J-683X	MG R	68kΩ 1/16W J
R1470	NRSA63J-223X	MG R	22kΩ 1/16W J
R1471	NRSA63J-273X	MG R	27kΩ 1/16W J
R1472	NRSA63J-682X	MG R	6.8kΩ 1/16W J
R1473	NRSA63J-123X	MG R	12kΩ 1/16W J
R1474	NRSA63J-563X	MG R	56kΩ 1/16W J
R1475	NRSA63J-153X	MG R	15kΩ 1/16W J
R1476	NRSA63J-123X	MG R	12kΩ 1/16W J
R1477	NRSA63J-123X	MG R	12kΩ 1/16W J
R1478	NRSA63J-123X	MG R	12kΩ 1/16W J
R1479	NRSA63J-154X	MG R	150kΩ 1/16W J
R1480	NRSA63J-823X	MG R	82kΩ 1/16W J
R1481	NRSA63J-472X	MG R	4.7kΩ 1/16W J
R1482	NRSA63J-272X	MG R	2.7kΩ 1/16W J
R1483	NRSA63J-472X	MG R	4.7kΩ 1/16W J
R1484	NRSA63J-473X	MG R	47kΩ 1/16W J
R1485	NRSA63J-123X	MG R	12kΩ 1/16W J
R1486	NRSA63J-472X	MG R	4.7kΩ 1/16W J
R1487	NRSA63J-183X	MG R	18kΩ 1/16W J
R1489	NRSA63J-333X	MG R	33kΩ 1/16W J

△ Symbol No.	Part No.	Part Name	Description
RESISTOR			
R1491	NRSA63J-332X	MG R	3.3kΩ 1/16W J
R1492	NRSA63J-562X	MG R	5.6kΩ 1/16W J
R1501	NRSA63J-0R0X	MG R	0.0Ω 1/16W J
R1504	NRSA63J-102X	MG R	1kΩ 1/16W J
R1511	NRSA63J-152X	MG R	1.5kΩ 1/16W J
R1512	NRSA63J-332X	MG R	3.3kΩ 1/16W J
R1521	NRSA63J-223X	MG R	22kΩ 1/16W J
R1522	NRSA63J-562X	MG R	5.6kΩ 1/16W J
R1551	NRSA63J-100X	MG R	10Ω 1/16W J
R1552	NRSA63J-124X	MG R	120kΩ 1/16W J
R1553	NRSA63J-683X	MG R	68kΩ 1/16W J
R1554	NRSA63J-562X	MG R	5.6kΩ 1/16W J
R1555	NRSA63J-333X	MG R	33kΩ 1/16W J
R1556	NRSA63J-472X	MG R	4.7kΩ 1/16W J
R1557	NRSA63J-562X	MG R	5.6kΩ 1/16W J
R1558	NRSA63J-104X	MG R	100kΩ 1/16W J
R1559	NRSA63J-154X	MG R	150kΩ 1/16W J
R1560	NRSA63J-100X	MG R	10Ω 1/16W J
R1561	QRM143J-0R0X	C R	0.0Ω 1/4W J
R1562	NRSA63J-683X	MG R	68kΩ 1/16W J
R1563	NRSA63J-103X	MG R	10kΩ 1/16W J
R1564	NRSA63J-223X	MG R	22kΩ 1/16W J
R1565	NRSA63J-562X	MG R	5.6kΩ 1/16W J
R1591	NRSA63J-561X	MG R	560Ω 1/16W J
R1592	NRSA63J-332X	MG R	3.3kΩ 1/16W J
R1595	NRSA63J-222X	MG R	2.2kΩ 1/16W J
R1596	NRSA63J-104X	MG R	100kΩ 1/16W J
R1601	NRSA63J-472X	MG R	4.7kΩ 1/16W J
R1603	NRSA63J-472X	MG R	4.7kΩ 1/16W J
R1604	NRSA63J-104X	MG R	100kΩ 1/16W J
R1605	NRSA63J-472X	MG R	4.7kΩ 1/16W J
R1607	NRSA63J-103X	MG R	10kΩ 1/16W J
R1608	NRSA63J-103X	MG R	10kΩ 1/16W J
R1609	NRSA63J-103X	MG R	10kΩ 1/16W J
R1613	NRSA63J-223X	MG R	22kΩ 1/16W J
R1614	NRSA63J-104X	MG R	100kΩ 1/16W J
R1616	NRSA63J-822X	MG R	8.2kΩ 1/16W J
R1617	NRSA63J-103X	MG R	10kΩ 1/16W J
R1618	NRSA63J-822X	MG R	8.2kΩ 1/16W J
R1619	NRSA63J-473X	MG R	47kΩ 1/16W J
R1622	NRSA63J-822X	MG R	8.2kΩ 1/16W J
R1623	NRSA63J-103X	MG R	10kΩ 1/16W J
R1624	NRSA63J-473X	MG R	47kΩ 1/16W J
R1625	NRSA63J-472X	MG R	4.7kΩ 1/16W J
R1626	NRSA63J-104X	MG R	100kΩ 1/16W J
R1627	NRSA63J-472X	MG R	4.7kΩ 1/16W J
R1628	NRSA63J-104X	MG R	100kΩ 1/16W J
R1629	NRSA63J-472X	MG R	4.7kΩ 1/16W J
R1630	NRSA63J-104X	MG R	100kΩ 1/16W J
R1631	NRSA63J-103X	MG R	10kΩ 1/16W J
R1632	NRSA63J-103X	MG R	10kΩ 1/16W J
R1633	NRSA63J-103X	MG R	10kΩ 1/16W J
R1637	NRSA63J-822X	MG R	8.2kΩ 1/16W J
R1638	NRSA63J-103X	MG R	10kΩ 1/16W J
R1639	NRSA63J-473X	MG R	47kΩ 1/16W J
R1640	NRSA63J-822X	MG R	8.2kΩ 1/16W J
R1641	NRSA63J-103X	MG R	10kΩ 1/16W J
R1642	NRSA63J-473X	MG R	47kΩ 1/16W J
R1643	NRSA63J-822X	MG R	8.2kΩ 1/16W J
R1646	NRSA63J-822X	MG R	8.2kΩ 1/16W J
R1649	NRSA63J-223X	MG R	22kΩ 1/16W J
R1650	NRSA63J-223X	MG R	22kΩ 1/16W J
R1651	NRSA63J-223X	MG R	22kΩ 1/16W J
R1652	NRSA63J-473X	MG R	47kΩ 1/16W J
R1653	NRSA63J-273X	MG R	27kΩ 1/16W J
R1655	NRSA63J-104X	MG R	100kΩ 1/16W J
R1656	NRSA63J-822X	MG R	8.2kΩ 1/16W J
R1657	NRSA63J-104X	MG R	100kΩ 1/16W J
R1701	NRSA63J-103X	MG R	10kΩ 1/16W J
R1702	NRSA63J-103X	MG R	10kΩ 1/16W J
R1703	NRSA63J-102X	MG R	1kΩ 1/16W J
R1704	NRSA63J-102X	MG R	1kΩ 1/16W J
R1706	NRSA63J-103X	MG R	10kΩ 1/16W J

Symbol No.	Part No.	Part Name	Description
RESISTOR			
R1707	NRSA63J-103X	MG R	10kΩ 1/16W J
R1708	NRSA63J-103X	MG R	10kΩ 1/16W J
R1709	QRE121J-151Y	C R	150Ω 1/2W J
R1711	NRSA63J-101X	MG R	100Ω 1/16W J
R1712	NRSA63J-101X	MG R	100Ω 1/16W J
R1714	NRSA63J-102X	MG R	1kΩ 1/16W J
R1715	NRSA63J-102X	MG R	1kΩ 1/16W J
R1720	NRSA63J-102X	MG R	1kΩ 1/16W J
R1721	NRSA63J-102X	MG R	1kΩ 1/16W J
R1722	NRSA63J-102X	MG R	1kΩ 1/16W J
R1772	NRSA63J-221X	MG R	220Ω 1/16W J
R1773	NRSA63J-221X	MG R	220Ω 1/16W J
R1774	NRSA63J-221X	MG R	220Ω 1/16W J
R1775	NRSA63J-221X	MG R	220Ω 1/16W J
R1776	NRSA63J-221X	MG R	220Ω 1/16W J
R1951	QRK126J-220X	C R	22Ω 1/2W J

Symbol No.	Part No.	Part Name	Description
CAPACITOR			
C1001	NCB31HK-222X	C CAP.	2200pF 50V K
C1002	QETN1HM-106Z	E CAP.	10μF 50V M
C1004	NCB31CK-104X	C CAP.	0.1μF 16V K
C1005	QETN1CM-108Z	E CAP.	1000μF 16V M
C1006	NCB31HK-103X	C CAP.	0.01μF 50V K
C1007	QETN1HM-106Z	E CAP.	10μF 50V M
C1009	NCB31CK-104X	C CAP.	0.1μF 16V K
C1010	QETN1HM-106Z	E CAP.	10μF 50V M
C1101	NCB31CK-104X	C CAP.	0.1μF 16V K
C1102	QETN1HM-106Z	E CAP.	10μF 50V M
C1103	NCB31CK-104X	C CAP.	0.1μF 16V K
C1104	QETN1CM-107Z	E CAP.	100μF 16V M
C1105	QETN1HM-106Z	E CAP.	10μF 50V M
C1106	NCB31CK-104X	C CAP.	0.1μF 16V K
C1107	NCB31CK-104X	C CAP.	0.1μF 16V K
C1111	NCB31HK-103X	C CAP.	0.01μF 50V K
C1116	NCB31HK-472X	C CAP.	4700pF 50V K
C1117	NCB31HK-103X	C CAP.	0.01μF 50V K
C1118	NCB31HK-103X	C CAP.	0.01μF 50V K
C1119	NDC31HJ-2R0X	C CAP.	2.0pF 50V J
C1120	NDC31HJ-2R0X	C CAP.	2.0pF 50V J
C1121	NCB31HK-103X	C CAP.	0.01μF 50V K
C1122	NDC31HJ-102X	C CAP.	1000pF 50V J
C1123	NDC31HJ-102X	C CAP.	1000pF 50V J
C1124	QETN1HM-106Z	E CAP.	10μF 50V M
C1125	QETN1HM-106Z	E CAP.	10μF 50V M
C1126	NCB31CK-104X	C CAP.	0.1μF 16V K
C1127	QETN1HM-106Z	E CAP.	10μF 50V M
C1128	NCB31CK-104X	C CAP.	0.1μF 16V K
C1129	NCF31AZ-105X	C CAP.	1μF 10V Z
C1130	QETN1HM-106Z	E CAP.	10μF 50V M
C1151	NCF31AZ-105X	C CAP.	1μF 10V Z
C1152	NCF31AZ-105X	C CAP.	1μF 10V Z
C1301	QETN1CM-107Z	E CAP.	100μF 16V M
C1302	NCB31CK-104X	C CAP.	0.1μF 16V K
C1303	NCB31CK-104X	C CAP.	0.1μF 16V K
C1305	NCB31CK-104X	C CAP.	0.1μF 16V K
C1306	NCB31CK-104X	C CAP.	0.1μF 16V K
C1307	NCB31CK-104X	C CAP.	0.1μF 16V K
C1308	NCB31CK-104X	C CAP.	0.1μF 16V K
C1309	NCB31CK-104X	C CAP.	0.1μF 16V K
C1310	QETN1AM-228Z	E CAP.	2200μF 10V M
C1311	NCB31CK-683X	C CAP.	0.068μF 16V K
C1312	NDC31HJ-221X	C CAP.	220pF 50V J
C1313	NCB31HK-223X	C CAP.	0.022μF 50V K
C1314	NCB31HK-223X	C CAP.	0.022μF 50V K
C1315	NCB31HK-223X	C CAP.	0.022μF 50V K
C1316	NCB31HK-103X	C CAP.	0.01μF 50V K
C1317	NCB31HK-103X	C CAP.	0.01μF 50V K
C1318	NCB31HK-103X	C CAP.	0.01μF 50V K
C1320	QETN0JM-228Z	E CAP.	2200μF 6.3V M
C1321	NCB31HK-223X	C CAP.	0.022μF 50V K
C1322	NCB31HK-223X	C CAP.	0.022μF 50V K
C1323	NCB31HK-223X	C CAP.	0.022μF 50V K
C1324	NDC31HJ-820X	C CAP.	82pF 50V J
C1351	QENC1EM-106Z	BP E CAP.	10μF 25V M
C1401	NCB31CK-104X	C CAP.	0.1μF 16V K
C1402	QETN1CM-107Z	E CAP.	100μF 16V M
C1403	NCB31CK-104X	C CAP.	0.1μF 16V K
C1404	NCB31CK-104X	C CAP.	0.1μF 16V K
C1454	NCB31EK-333X	C CAP.	0.033μF 25V K

Symbol No.	Part No.	Part Name	Description
CAPACITOR			
C1455	NCB31CK-104X	C CAP.	0.1μF 16V K
C1456	NCB31CK-104X	C CAP.	0.1μF 16V K
C1457	NCB31EK-333X	C CAP.	0.033μF 25V K
C1491	NCB31EK-473X	C CAP.	0.047μF 25V K
C1471	NCB31CK-104X	C CAP.	0.1μF 16V K
C1472	NCB31HK-103X	C CAP.	0.01μF 50V K
C1473	NCB31CK-104X	C CAP.	0.1μF 16V K
C1474	NCB31EK-333X	C CAP.	0.033μF 25V K
C1475	NCB31CK-104X	C CAP.	0.1μF 16V K
C1501	NDC31HJ-150X	C CAP.	15pF 50V J
C1502	NDC31HJ-150X	C CAP.	15pF 50V J
C1551	NCF31CZ-224X	C CAP.	0.22μF 16V Z
C1552	NCF31CZ-224X	C CAP.	0.22μF 16V Z
C1553	QETN1EM-476Z	E CAP.	47μF 25V M
C1554	NCF31CZ-224X	C CAP.	0.22μF 16V Z
C1555	NCF31CZ-224X	C CAP.	0.22μF 16V Z
C1560	QETN1CM-107Z	E CAP.	100μF 16V M
C1561	NDC31HJ-561X	C CAP.	560pF 50V J
C1562	QETN1HM-105Z	E CAP.	1μF 50V M
C1564	NCB31CK-104X	C CAP.	0.1μF 16V K
C1591	NDC31HJ-471X	C CAP.	470pF 50V J
C1596	NCB31CK-104X	C CAP.	0.1μF 16V K
C1601	QETN1HM-106Z	E CAP.	10μF 50V M
C1602	QETN1HM-106Z	E CAP.	10μF 50V M
C1603	QETN1HM-106Z	E CAP.	10μF 50V M
C1604	QETN1HM-107Z	E CAP.	100μF 50V M
C1611	QETN1EM-108Z	E CAP.	1000μF 25V M
C1612	QETN1EM-108Z	E CAP.	1000μF 25V M
C1613	QETN1EM-108Z	E CAP.	1000μF 25V M
C1614	QETN1HM-106Z	E CAP.	10μF 50V M
C1616	QETN1HM-106Z	E CAP.	10μF 50V M
C1617	QETN1HM-106Z	E CAP.	10μF 50V M
C1618	QETN1HM-106Z	E CAP.	10μF 50V M
C1619	QETN1HM-106Z	E CAP.	10μF 50V M
C1620	QETN1HM-107Z	E CAP.	100μF 50V M
C1621	QETM1VM-228	E CAP.	2200μF 35V M
C1628	QETN1EM-108Z	E CAP.	1000μF 25V M
C1629	QETM1EM-338	E CAP.	3300μF 25V M
C1630	QETN1EM-108Z	E CAP.	1000μF 25V M
C1631	QETN1HM-106Z	E CAP.	10μF 50V M
C1633	QETN1HM-106Z	E CAP.	10μF 50V M
C1634	QETN1CM-108Z	E CAP.	1000μF 16V M
C1635	QETM1VM-228	E CAP.	2200μF 35V M
C1636	QETN1HM-107Z	E CAP.	100μF 50V M
C1637	QETN1HM-107Z	E CAP.	100μF 50V M
C1638	NCB31HK-104X	C CAP.	0.1μF 50V K
C1639	QETN1CM-108Z	E CAP.	1000μF 16V M
C1640	QETN1CM-107Z	E CAP.	100μF 16V M
C1641	QETN1CM-107Z	E CAP.	100μF 16V M
C1642	NCB31HK-104X	C CAP.	0.1μF 50V K
C1701	QETN1HM-106Z	E CAP.	10μF 50V M
C1702	NCB31CK-563X	C CAP.	0.056μF 16V K
C1703	QETN1CM-107Z	E CAP.	100μF 16V M
C1951	QETN1CM-477Z	E CAP.	470μF 16V M
C1952	NCB31CK-104X	C CAP.	0.1μF 16V K
C1953	NCB31CK-104X	C CAP.	0.1μF 16V K
C1954	QETN1AM-477Z	E CAP.	470μF 10V M
C1955	QETN1AM-227Z	E CAP.	220μF 10V M
C1956	QETN1AM-107Z	E CAP.	100μF 10V M

Symbol No.	Part No.	Part Name	Description
COIL			
L1001	QLL244K-270Z	COIL	27μH K
L1002	QLL244K-100Z	COIL	10μH K
L1003	QLL244K-100Z	COIL	10μH K
L1101	QRN143J-0R0X	C R	0.0Ω 1/4W J
L1102	QLL244K-4R7Z	COIL	4.7μH K
L1301	NQL092K-1R5X	COIL	1.5μH
L1302	NQL092K-1R5X	COIL	1.5μH
L1951	QLL26AM-5R6Z	COIL	5.6μH M

Symbol No.	Part No.	Part Name	Description
DIODE			
D1311	MA3051/M/-X	ZENER DIODE	
D1314	MA111-X	SI DIODE	
D1317	MA111-X	SI DIODE	
D1318	MA111-X	SI DIODE	
D1319	MA3036-X	ZENER DIODE	
D1320	MA3056/M/-X	ZENER DIODE	
D1321	MA3056/M/-X	ZENER DIODE	

△ Symbol No.	Part No.	Part Name	Description
DIODE			
D1471	MA111-X	SI. DIODE	
D1472	MA111-X	SI. DIODE	
D1473	MA111-X	SI. DIODE	
D1474	MA111-X	SI. DIODE	
D1475	MA3240/M/-X	ZENER DIODE	
D1521	MA111-X	SI. DIODE	
D1591	MA111-X	SI. DIODE	
D1592	MA3051/M/-X	ZENER DIODE	
D1593	MA111-X	SI. DIODE	
D1601	MA3330/L/-X	ZENER DIODE	
D1602	MA3330/L/-X	ZENER DIODE	
D1603	MA3330/L/-X	ZENER DIODE	
D1604	MA111-X	SI. DIODE	
D1606	MA111-X	SI. DIODE	
D1607	MA111-X	SI. DIODE	
D1608	MA111-X	SI. DIODE	
D1610	MA111-X	SI. DIODE	
D1611	MA3330/L/-X	ZENER DIODE	
D1612	MA3330/L/-X	ZENER DIODE	
D1613	MA3330/L/-X	ZENER DIODE	
D1614	MA111-X	SI. DIODE	
D1615	MA111-X	SI. DIODE	
D1616	MA111-X	SI. DIODE	
D1617	MA111-X	SI. DIODE	
D1618	MA111-X	SI. DIODE	
D1619	MA111-X	SI. DIODE	
D1620	MA111-X	SI. DIODE	
D1621	MA111-X	SI. DIODE	
D1622	MA111-X	SI. DIODE	
D1623	MA111-X	SI. DIODE	
D1624	MA111-X	SI. DIODE	
D1771	MA3056/M/-X	ZENER DIODE	
D1772	MA3056/M/-X	ZENER DIODE	
D1773	MA3056/M/-X	ZENER DIODE	
D1774	MA3056/M/-X	ZENER DIODE	
D1775	MA3033-X	ZENER DIODE	
D1951	1SR35-400A-T2	SI. DIODE	
D1981	MA111-X	SI. DIODE	
D1982	MA111-X	SI. DIODE	

TRANSISTOR

Q1101	2SC2412K/QR/-X	SI. TRANSISTOR	
Q1102	2SC2412K/QR/-X	SI. TRANSISTOR	
Q1301	2SA1037AK/QR/-X	SI. TRANSISTOR	
Q1471	2SC2412K/QR/-X	SI. TRANSISTOR	
Q1472	2SC2412K/QR/-X	SI. TRANSISTOR	
Q1561	2SC2412K/QR/-X	SI. TRANSISTOR	
Q1562	2SA1037AK/QR/-X	SI. TRANSISTOR	
Q1591	2SA1037AK/QR/-X	SI. TRANSISTOR	
Q1592	2SC2412K/QR/-X	SI. TRANSISTOR	
Q1601	2SA1037AK/QR/-X	SI. TRANSISTOR	
Q1603	DTC144EKA-X	DIGI. TRANSISTOR	
Q1605	DTC144EKA-X	DIGI. TRANSISTOR	
Q1606	2SC2412K/QR/-X	SI. TRANSISTOR	
Q1608	DTC144EKA-X	DIGI. TRANSISTOR	
Q1609	2SC2412K/QR/-X	SI. TRANSISTOR	
Q1611	2SA1037AK/QR/-X	SI. TRANSISTOR	
Q1612	DTC144EKA-X	DIGI. TRANSISTOR	
Q1613	DTC144EKA-X	DIGI. TRANSISTOR	
Q1614	DTC144EKA-X	DIGI. TRANSISTOR	
Q1615	DTC144EKA-X	DIGI. TRANSISTOR	
Q1616	2SC2412K/QR/-X	SI. TRANSISTOR	
Q1617	DTC144EKA-X	DIGI. TRANSISTOR	
Q1618	2SC2412K/QR/-X	SI. TRANSISTOR	
Q1620	2SA1037AK/QR/-X	SI. TRANSISTOR	

IC

IC1101	MSP3415DQGB3GHX	IC	
IC1301	SDA9380	IC	
IC1402	BA10324AF-XE	IC	
IC1471	BA10358F-XE	IC	
IC1551	LA6515	I C	
IC1601	AN7585	IC	
IC1602	AN7585	IC	
IC1603	AN78L24-T	IC	
IC1604	AN78L05-T	IC	
IC1701	JLC1562BF-X	I C	
IC1951	BA09T	IC	
IC1952	BA08T	IC	

OTHERS

CN1002	QGF1220C2-25	FFC/FPC CONNE	
K1001	NQR0389-003X	FERRITE BEADS	

△ Symbol No.	Part No.	Part Name	Description
OTHERS			
K1101	NQR0389-003X	FERRITE BEADS	
K1102	NQR0389-003X	FERRITE BEADS	
K1301	NQR0413-003X	FERRITE BEADS	
LC1102	NQR0431-001X	EMI FILTER	
LC1301	NQR0431-001X	EMI FILTER	
LC1302	NQR0431-001X	EMI FILTER	
LC1303	NQR0431-001X	EMI FILTER	
TU1001	QAU0276-001	TUNER	
X1101	CE42546-001Z	CRYSTAL	
X1501	QAX0549-001Z	CRYSTAL	

POWER & DEF. P.W. BOARD ASS'Y (SMF-2405A)

Symbol No.	Part No.	Part Name	Description
RESISTOR			
R2401	QRE141J-562Y	C R	5.6kΩ 1/4W J
R2402	QRE141J-562Y	C R	5.6kΩ 1/4W J
R2403	QRE141J-222Y	C R	2.2kΩ 1/4W J
R2404	QRX01GJ-1R0	MF R	1.0Ω 1W J
R2405	QRL029J-151	OM R	150Ω 2W J
R2406	QRE141J-222Y	C R	2.2kΩ 1/4W J
R2407	QRX01GJ-1R5	MF R	1.5Ω 1W J
R2408	QRX01GJ-1R5	MF R	1.5Ω 1W J
R2409	QRE141J-823Y	C R	82kΩ 1/4W J
R2410	QRE141J-103Y	C R	10kΩ 1/4W J
R2421	QRE141J-103Y	C R	10kΩ 1/4W J
R2422	QRE141J-274Y	C R	270kΩ 1/4W J
R2461	QRG029J-820	OM R	82Ω 2W J
R2462	QRE141J-473Y	C R	47kΩ 1/4W J
R2463	QRA14CF-9101Y	MF R	9.1kΩ 1/4W F
R2464	QRX01GJ-2R7	MF R	2.7Ω 1W J
R2468	QRE141J-102Y	C R	1kΩ 1/4W J
R2469	QRE141J-272Y	C R	2.7kΩ 1/4W J
R2471	QRE141J-391Y	C R	390Ω 1/4W J
R2472	QRA14CF-1002Y	MF R	10kΩ 1/4W F
R2473	QRE141J-473Y	C R	47kΩ 1/4W J
R2474	QRE141J-103Y	C R	10kΩ 1/4W J
R2475	QRE141J-102Y	C R	1kΩ 1/4W J
R2476	QRE141J-102Y	C R	1kΩ 1/4W J
R2477	QRE141J-563Y	C R	56kΩ 1/4W J
R2478	QRE141J-333Y	C R	33kΩ 1/4W J
R2501	QRE141J-471Y	C R	470Ω 1/4W J
R2502	QRE141J-123Y	C R	12kΩ 1/4W J
R2503	QRE121J-152Y	C R	1.5kΩ 1/2W J
R2504	QRL039J-272	OM R	2.7kΩ 3W J
R2505	QRL039J-332	OM R	3.3kΩ 3W J
R2506	QRE121J-5R6Y	C R	5.6Ω 1/2W J
R2521	QRE121J-471Y	C R	470Ω 1/2W J
R2522	QRE141J-223Y	C R	22kΩ 1/4W J
R2523	QRE141J-103Y	C R	10kΩ 1/4W J
R2524	QRC121K-152Z	COMP. R	1.5kΩ 1/2W K
R2525	QRL039J-103	OM R	10kΩ 3W J
R2541	QRE141J-182Y	C R	1.8kΩ 1/4W J
R2542	QRE141J-222Y	C R	2.2kΩ 1/4W J
R2543	QRE121J-272Y	C R	2.7kΩ 1/2W J
△ R2551	QRZ9022-R47	F R	0.47 Ω 1W K
△ R2552	QRZ9022-R47	F R	0.47 Ω 1W K
R2581	QRF154K-4R7	UNF R	4.7Ω 15W K
R2582	QRE141J-681Y	C R	680Ω 1/4W J
R2583	QRE121J-682Y	C R	6.8kΩ 1/2W J
R2584	QRE141J-183Y	C R	18kΩ 1/4W J
R2585	QRE141J-222Y	C R	2.2kΩ 1/4W J
R2586	QRA14CF-7501Y	MF R	7.5kΩ 1/4W F
R2587	QRA14CF-2101Y	MF R	2.1kΩ 1/4W F
R2588	QRE141J-103Y	C R	10kΩ 1/4W J
△ R2591	QRZ9017-4R7	F R	4.7 Ω 1/4W J
R2901	QRE121J-331Y	C R	330Ω 1/2W J
△ R2902	QRF054K-3R3	UNF R	3.3Ω 5W K
△ R2903	QRF104K-3R9	UNF R	3.9Ω 10W K
R2904	QRL039J-683	OM R	68kΩ 3W J
R2905	QRE121J-474Y	C R	470kΩ 1/2W J
R2906	QRE121J-474Y	C R	470kΩ 1/2W J
R2908	QRL039J-823	OM R	82kΩ 3W J
R2909	QRL039J-823	OM R	82kΩ 3W J
△ R2910	QRE121J-150Y	C R	15Ω 1/2W J
R2911	QRE121J-152Y	C R	1.5kΩ 1/2W J
R2914	QRMO59J-R10	MP R	0.10Ω 5W J
R2915	QRE121J-681Y	C R	680Ω 1/2W J
R2916	QRE121J-332Y	C R	3.3kΩ 1/2W J
R2931	QRE141J-1R0Y	C R	1.0Ω 1/4W J
R2932	QRE141J-1R5Y	C R	1.5Ω 1/4W J
R2933	QRE141J-1R8Y	C R	1.8Ω 1/4W J
R2944	QRE141J-103Y	C R	10kΩ 1/4W J
R2945	QRE141J-563Y	C R	56kΩ 1/4W J
R2946	QRE141J-103Y	C R	10kΩ 1/4W J
R2951	QRE121J-102Y	C R	1kΩ 1/2W J
R2952	QRL039J-223	OM R	22kΩ 3W J
R2954	QRE141J-103Y	C R	10kΩ 1/4W J
R2959	QRT039J-R68	MF R	0.68Ω 3W J
R2961	QRE141J-332Y	C R	3.3kΩ 1/4W J
R2963	QRL039J-561	OM R	560Ω 3W J
R2964	QRT039J-1R5	MF R	1.5Ω 3W J
R2981	QRE141J-153Y	C R	15kΩ 1/4W J
R2982	QRE141J-102Y	C R	1kΩ 1/4W J

Symbol No.	Part No.	Part Name	Description
------------	----------	-----------	-------------

RESISTOR

△ R2991	QRZ9046-825Z	C R	8.2MΩ 1/2W K
---------	--------------	-----	--------------

CAPACITOR

C2404	QCZ0120-104Z	C CAP.	0.1μF 25V Z
C2405	QDC31HJ-820Z	C CAP.	82pF 50V J
C2406	QETM1VM-108	E CAP.	1000μF 35V M
C2408	QETN1VM-337Z	E CAP.	330μF 35V M
C2409	QFV71HJ-474Z	MF CAP.	0.47μF 50V J
C2410	QFV71HJ-474Z	MF CAP.	0.47μF 50V J
C2411	QFLC2AJ-104Z	M CAP.	0.1μF 100V J
C2414	QCB31HK-682Z	C CAP.	6800pF 50V K
C2421	QETN1HM-105Z	E CAP.	1μF 50V M
C2461	QEZO414-226	E CAP.	22μF 50V M
C2462	QFM72DJ-152Z	M CAP.	1500pF 200V J
C2463	QFM72DJ-152Z	M CAP.	1500pF 200V J
C2464	QCZ0120-104Z	C CAP.	0.1μF 25V Z
C2465	QETN1HM-106Z	E CAP.	10μF 50V M
C2466	QFP31HJ-272Z	PP CAP.	2700pF 50V J
C2467	QFLC1HJ-102Z	M CAP.	1000pF 50V J
C2468	QETN1EM-476Z	E CAP.	47μF 25V M
C2470	QCS31HJ-470Z	C CAP.	47pF 50V J
C2471	QFLC1HJ-103Z	M CAP.	0.01μF 50V J
C2501	QCB32HK-331Z	C CAP.	330pF 500V K
C2502	QFM72DK-103	M CAP.	0.01μF 200V K
C2503	QFV71HJ-224Z	MF CAP.	0.22μF 50V J
△ C2521	QFZ0122-112	MPP CAP.	1100pF 1.8KVH±3%
△ C2522	QFZ0200-113	MPP CAP.	0.01μF 1.5KVH±3%
C2523	QFM72DK-393	M CAP.	0.039μF 200V K
△ C2524	QFP32JJ-223	PP CAP.	0.022μF 630V J
C2526	QFZ0197-184	MPP CAP.	0.18μF 250V J
C2527	QFZ0197-124	MPP CAP.	0.12μF 250V J
C2529	QFZ0197-154	MPP CAP.	0.15μF 250V J
C2530	QCB32HK-561Z	C CAP.	560pF 500V K
C2531	QFZ0194-534	MPP CAP.	0.53μF 250V J
C2532	QETM2CM-22Z	E CAP.	220μF 160V M
C2533	QETN2EM-475Z	E CAP.	4.7μF 250V M
C2541	QENC1HM-105Z	E CAP.	1μF 50V M
C2551	QCB32HK-152Z	C CAP.	1500pF 500V K
C2552	QETN1CM-108Z	E CAP.	1000pF 16V M
C2553	QCB32HK-152Z	C CAP.	1500pF 500V K
C2554	QETN1CM-108Z	E CAP.	1000pF 16V M
C2555	QCB32HK-102Z	C CAP.	1000pF 500V K
C2556	QETN2EM-106Z	E CAP.	10μF 250V M
C2558	QETN1CM-477Z	E CAP.	470μF 16V M
C2559	QEHR1CM-227Z	E CAP.	220μF 16V M
C2581	QETN1CM-107Z	E CAP.	100μF 16V M
C2582	QETN1EM-476Z	E CAP.	47μF 25V M
C2583	QETN2AM-106Z	E CAP.	10μF 100V M
C2584	QETN1AM-227Z	E CAP.	220μF 10V M
△ C2901	QFZ9072-473	MF CAP.	0.047μF FAC275V K
△ OR	QFZ9075-473	MPP CAP.	0.047μF FAC275V M
△ C2902	QFZ9072-104	MF CAP.	0.1μF FAC275V K
△ OR	QFZ9075-104	MPP CAP.	0.1μF FAC275V M
△ C2903	QFZ9072-473	MF CAP.	0.047μF FAC275V K
△ OR	QFZ9075-473	MPP CAP.	0.047μF FAC275V M
△ C2904	QCZ9054-47Z	C CAP.	4700pF FAC250V Z
△ C2905	QCZ9054-47Z	C CAP.	4700pF FAC250V Z
△ C2906	QCZ9054-47Z	C CAP.	4700pF FAC250V Z
C2907	QEZO199-227	E CAP.	220μF 400V M
C2908	QCB32HK-103	C CAP.	0.01μF 500V K
C2909	QCZ0340-391	C CAP.	390pF 2kV K
C2910	QETN1HM-476Z	E CAP.	47μF 50V M
C2911	QCB31HK-102Z	C CAP.	1000pF 50V K
C2912	QCZ0340-561	C CAP.	560pF 2kV K
C2914	QCB31HK-471Z	C CAP.	470pF 50V K
C2915	QFLC1HJ-104Z	M CAP.	0.1μF 50V J
C2916	QCB32HK-152Z	C CAP.	1500pF 500V K
△ C2931	QCZ9054-47Z	C CAP.	4700pF FAC250V Z
△ C2932	QCZ9054-47Z	C CAP.	4700pF FAC250V Z
△ C2933	QCZ9054-47Z	C CAP.	4700pF FAC250V Z
△ C2934	QETM2GM-226	E CAP.	22μF 400V M
C2941	QTMN1CM-477Z	E CAP.	470μF 16V M
C2942	QETN1AM-337Z	E CAP.	330μF 10V M
C2951	QEZO203-227	E CAP.	220μF 160V M
C2952	QETN1CM-108Z	E CAP.	1000μF 16V M
C2954	QETM1VM-338	E CAP.	3300μF 35V M
C2955	QETM1VM-228	E CAP.	2200μF 35V M
C2956	QETN1AM-108Z	E CAP.	1000μF 10V M
C2957	QETN1AM-228Z	E CAP.	2200μF 10V M
C2959	QFV71HJ-684Z	MF CAP.	0.68μF 50V J

△ Symbol No.	Part No.	Part Name	Description
CAPACITOR			
C2960	QCZ0325-821	C CAP.	820pF 2kV K
C2972	QETN1AM-477Z	E CAP.	470μF 10V M
C2973	QETN1AM-477Z	E CAP.	470μF 10V M
C2974	QETNOJM-228Z	E CAP.	2200μF 6.3V M
C2975	QETN1AM-228Z	E CAP.	2200μF 10V M
△ C2991	QCZ9079-22Z	C CAP.	2200pFAC250V M
△ C2993	QCZ9079-471	C CAP.	470pFAC250V K

TRANSFORMER			
T2501	QQR1111-001	DRIVE TRANSF.	
△ T2551	QQH0126-001	F. B. TRANSF.	
△ T2901	QQS0176-001	SW TRANSF	

COIL			
L2461	QQR1195-001	CHOKE COIL	
L2462	QQLZ028-27Z	INDUCTOR	
L2521	QQLZ031-180	INDUCTOR	
L2522	QQR1191-00Z	LINEARITY COIL	
L2551	QQLZ026-540	INDUCTOR	
L2552	QQLZ26AK-220Z	COIL	22μH K
L2901	QQL401K-100Z	COIL	10μH K
L2902	QQL401K-100Z	COIL	10μH K
L2903	QQR1200-001	CHOKE COIL	
L2951	QQLZ026-460	INDUCTOR	
L2959	QQLZ26AK-220Z	COIL	22μH K
L2960	QQLZ26AK-220Z	COIL	22μH K
L2961	QQLZ26AM-4R7Z	INDUCTOR	

DIODE			
D2402	1SR35-400A-T2	SI. DIODE	
D2421	1SS133-T2	SI. DIODE	
D2461	RGPI0J-5025-T3	SI. DIODE	
D2462	1SS133-T2	SI. DIODE	
D2463	1SS133-T2	SI. DIODE	
D2501	1SS81-T5	SI. DIODE	
D2521	V11CA-C1	SI. DIODE	
D2522	FMV-3FU-F1	SI. DIODE	
D2523	MTZJ22B-T2	ZENER DIODE	
D2525	RGPI0J-5025-T3	SI. DIODE	
D2541	RGPI0J-5025-T3	SI. DIODE	
D2542	MTZJ3.9B-T2	ZENER DIODE	
D2551	RGPI0J-5025-T3	SI. DIODE	
D2552	RGPI0J-5025-T3	SI. DIODE	
D2553	RH15-T3	SI. DIODE	
D2582	MTZJ7.5B-T2	ZENER DIODE	
D2583	MTZJ7.5S-T2	ZENER DIODE	
△ D2584	RGPI0J-5025-T3	SI. DIODE	
△ D2901	D3SB60	BRIDGE DIODE	
D2902	RG1C-LFA1	SI. DIODE	
D2904	EU2A-T2	SI. DIODE	
D2905	1SS133-T2	SI. DIODE	
D2906	MTZJ27B-T2	ZENER DIODE	
D2907	1SS133-T2	SI. DIODE	
D2908	1SS133-T2	SI. DIODE	
D2910	MTZJ15B-T2	ZENER DIODE	
D2911	1SS133-T2	SI. DIODE	
△ D2931	S1WB/A/60-4101	BRIDGE DIODE	
D2945	1SS133-T2	SI. DIODE	
D2951	RU4AM-LFT2	SI. DIODE	
D2952	RU3YX-LFC4	SI. DIODE	
D2953	RU4AM-LFT2	SI. DIODE	
D2954	FMX-G12S	SI. DIODE	
D2955	RU3YX-LFC4	SI. DIODE	
D2956	RU3YX-LFC4	SI. DIODE	
D2958	MTZJ33B-T2	ZENER DIODE	
D2959	RU3YX-LFC4	SI. DIODE	
D2960	1SR124-400A-T2	SI. DIODE	
D2961	1SS133-T2	SI. DIODE	
D2981	1SS133-T2	SI. DIODE	
D2984	1SS133-T2	SI. DIODE	
D2985	1SS133-T2	SI. DIODE	

TRANSISTOR			
Q2421	DTC124ESA-T	DIGI. TRANSISTOR	
Q2422	2SC1740S/QR/-T	SI. TRANSISTOR	
Q2461	2SK2459N-F54	POWER MOS FET	
Q2462	2SC1740S/QR/-T	SI. TRANSISTOR	
Q2463	2SC1740S/QR/-T	SI. TRANSISTOR	
Q2464	2SA933AS/QR/-T	SI. TRANSISTOR	
Q2501	BSN304-T	MOS FET	
△ Q2521	2SC5904-RL	POWER TRANSISTOR	H. OUT
Q2581	2SA1208/ST/Z1-T	SI. TRANSISTOR	

△ Symbol No.	Part No.	Part Name	Description
TRANSISTOR			
Q2582	DTC144ESA-T	DIGI. TRANSISTOR	
Q2583	2SC1740S/QR/-T	SI. TRANSISTOR	
Q2941	2SC1740S/QR/-T	SI. TRANSISTOR	
Q2942	2SC1740S/QR/-T	SI. TRANSISTOR	

IC			
IC2401	ANS523	IC	
IC2461	BA10393	IC	
IC2551	BA12T	IC	
IC2901	STR-F6667B/F7	IC	
△ IC2902	QAL0425-001	POWER MODULE	
IC2951	SE140N	IC	
IC2954	BA05T	IC	
IC2955	NJM2396F33	IC	

OTHERS			
△ CP2951	ICP-N75-Y	I. C. PROTECT	
△ CP2952	ICP-N75-Y	I. C. PROTECT	
△ CP2953	ICP-N75-Y	I. C. PROTECT	
△ CP2954	QMFZ049-4R0Z-E	FUSE	4.0A
△ CP2955	ICP-N75-Y	I. C. PROTECT	
K2401	QQR0621-002Z	FERRITE BEADS	
K2522	CE41832-001	LEAD CORE	
K2523	CE41832-001	LEAD CORE	
K2524	CE41832-001	LEAD CORE	
K2901	QQR0679-001	FERRITE BEADS	
△ LF2901	QQR1095-001	LINE FILTER	
△ PC2901	PC123FY2	IC (PHOTO COUPLE	
△ RY2931	OSK0099-001	RELAY	
△ TH2901	QAD0133-9R0	THERMISTOR	

■ CRT SOCKET P.W. BOARD ASS'Y (SMF-3407A)

△ Symbol No.	Part No.	Part Name	Description
RESISTOR			
R3101	NRSA63J-223X	MG R	22kΩ 1/16W J
R3102	NRSA63J-681X	MG R	680Ω 1/16W J
R3103	NRSA63J-101X	MG R	100Ω 1/16W J
R3104	NRSA63J-822X	MG R	8.2kΩ 1/16W J
R3105	NRSA63J-102X	MG R	1kΩ 1/16W J
R3106	NRSA63J-221X	MG R	220Ω 1/16W J
R3107	NRSA63J-561X	MG R	560Ω 1/16W J
R3109	NRSA63J-153X	MG R	15kΩ 1/16W J
R3110	NRSA63J-222X	MG R	2.2kΩ 1/16W J
R3111	NRSA63J-471X	MG R	470Ω 1/16W J
R3112	NRSA63J-272X	MG R	2.7kΩ 1/16W J
R3113	NRSA63J-152X	MG R	1.5kΩ 1/16W J
R3114	NRSA63J-152X	MG R	1.5kΩ 1/16W J
R3115	NRSA63J-390X	MG R	39Ω 1/16W J
R3116	QRG01GJ-101	OM R	100Ω 1W J
R3117	NRSA63J-331X	MG R	330Ω 1/16W J
R3122	NRSA63J-122X	MG R	1.2kΩ 1/16W J
R3123	QRE121J-563Y	C R	56kΩ 1/2W J
R3124	NRSA63J-470X	MG R	47Ω 1/16W J
R3125	QRE121J-563Y	C R	56kΩ 1/2W J
R3126	NRSA63J-470X	MG R	47Ω 1/16W J
R3127	NRSA63J-122X	MG R	1.2kΩ 1/16W J
R3128	NRSA63J-390X	MG R	39Ω 1/16W J
R3129	QRE121J-2R7Y	C R	2.7Ω 1/2W J
R3130	QRE121J-2R7Y	C R	2.7Ω 1/2W J
R3131	NRSA63J-390X	MG R	39Ω 1/16W J
R3132	NRSA63J-121X	MG R	120Ω 1/16W J
R3133	QRL029J-681	OM R	680Ω 2W J
△ R3134	QRZ9021-561	F R	560 Ω 1W J
R3204	NRSA63J-272X	MG R	2.7kΩ 1/16W J
R3205	NRSA63J-272X	MG R	2.7kΩ 1/16W J
R3206	NRSA63J-272X	MG R	2.7kΩ 1/16W J
R3211	NRSA63J-154X	MG R	150kΩ 1/16W J
R3223	NRSA63J-272X	MG R	2.7kΩ 1/16W J
R3224	NRSA63J-272X	MG R	2.7kΩ 1/16W J
R3225	NRSA63J-272X	MG R	2.7kΩ 1/16W J
R3227	NRSA63J-103X	MG R	10kΩ 1/16W J
R3228	NRSA63J-272X	MG R	2.7kΩ 1/16W J
R3229	QRL029J-104-F	OM R	100kΩ 2W J
R3230	QRL029J-104-F	OM R	100kΩ 2W J
R3231	QRL029J-104-F	OM R	100kΩ 2W J
R3232	NRSA63J-332X	MG R	3.3kΩ 1/16W J
R3233	NRSA63J-332X	MG R	3.3kΩ 1/16W J
R3234	NRSA63J-332X	MG R	3.3kΩ 1/16W J
R3235	QRC121K-152Z	COMP. R	1.5kΩ 1/2W K
R3236	QRC121K-152Z	COMP. R	1.5kΩ 1/2W K
R3237	QRC121K-152Z	COMP. R	1.5kΩ 1/2W K
R3239	QRZ0107-474Z	C R	470kΩ 1/2W K
R3240	QRC121K-102Z	COMP. R	1kΩ 1/2W K
R3241	QRZ0107-105Z	C R	1.0MΩ 1/2W K
R3242	NRSA63J-103X	MG R	10kΩ 1/16W J
R3244	NRSA63J-102X	MG R	1kΩ 1/16W J
R3245	NRSA63J-562X	MG R	5.6kΩ 1/16W J
R3246	NRSA63J-562X	MG R	5.6kΩ 1/16W J
R3247	NRSA63J-562X	MG R	5.6kΩ 1/16W J
R3301	QRE121J-474Y	C R	470kΩ 1/2W J
R3302	QRE121J-474Y	C R	470kΩ 1/2W J
R3303	NRSA63J-223X	MG R	22kΩ 1/16W J
R3304	NRSA63J-223X	MG R	22kΩ 1/16W J
R3305	NRSA63J-562X	MG R	5.6kΩ 1/16W J
R3306	NRSA63J-392X	MG R	3.9kΩ 1/16W J
R3310	NRSA63J-0R0X	MG R	0.0Ω 1/16W J
CAPACITOR			
C3102	NDC31HJ-6R0X	C CAP.	6.0pF 50V J
C3103	NDC31HJ-390X	C CAP.	39pF 50V J
C3104	QCB31HK-103Z	C CAP.	0.01μF 50V K
C3106	QETN1EM-335Z	E CAP.	3.3μF 50V M
C3107	QETN1CM-107Z	E CAP.	100μF 16V M
C3110	QETN2CM-106Z	E CAP.	10μF 160V M
C3111	QCB32HK-472Z	C CAP.	4700pF 500V K
C3113	QETN2CM-106Z	E CAP.	10μF 160V M
C3114	QCB32HK-472Z	C CAP.	4700pF 500V K
C3116	QETN1AM-107Z	E CAP.	100μF 10V M
C3117	QETN1AM-107Z	E CAP.	100μF 10V M
C3118	QETN1AM-337Z	E CAP.	330μF 10V M
C3120	NDC31HJ-221X	C CAP.	220pF 50V J
C3121	NDC31HJ-221X	C CAP.	220pF 50V J
C3201	NDC31HJ-100X	C CAP.	10pF 50V J
C3202	NDC31HJ-100X	C CAP.	10pF 50V J

△ Symbol No.	Part No.	Part Name	Description
CAPACITOR			
C3203	NDC31HJ-100X	C CAP.	10pF 50V J
C3204	NCF31CZ-104X	C CAP.	0.1μF 16V Z
C3205	NCF31CZ-104X	C CAP.	0.1μF 16V Z
C3206	NCF31CZ-104X	C CAP.	0.1μF 16V Z
C3207	QETN1EM-476Z	E CAP.	47μF 25V M
C3208	QETN1EM-476Z	E CAP.	47μF 25V M
C3209	QETN1EM-476Z	E CAP.	47μF 25V M
C3210	QFK62EK-104Z	MM CAP.	0.1μF 250V K
C3211	QFK62EK-104Z	MM CAP.	0.1μF 250V K
C3212	QFK62EK-104Z	MM CAP.	0.1μF 250V K
C3213	NDC31HJ-181X	C CAP.	180pF 50V J
C3214	NDC31HJ-181X	C CAP.	180pF 50V J
C3215	NDC31HJ-181X	C CAP.	180pF 50V J
C3216	QETN1CM-107Z	E CAP.	100μF 16V M
C3218	QETN2EM-336	E CAP.	33μF 250V M
C3219	QFZ0097-223	MM CAP.	0.022μF 1250V K
C3221	QETN2EM-106Z	E CAP.	10μF 250V M
C3302	QETN1HM-476Z	E CAP.	47μF 50V M
COIL			
L3101	QQL244K-5R6Z	COIL	5.6μH K
L3204	QQL26AJ-102Z	COIL	1mH J
DIODE			
D3101	MA111-X	SI. DIODE	
D3102	MA111-X	SI. DIODE	
D3103	RH15-T3	SI. DIODE	
D3104	RH15-T3	SI. DIODE	
D3204	EU01N-T2	SI. DIODE	
D3205	EU01N-T2	SI. DIODE	
D3206	EU01N-T2	SI. DIODE	
D3207	RM2C-LFA1	SI. DIODE	
D3208	1SR124-400A-T2	SI. DIODE	
D3209	1SR124-400A-T2	SI. DIODE	
D3210	1SR124-400A-T2	SI. DIODE	
D3211	MA3062/M/-X	ZENER DIODE	
D3301	MA111-X	SI. DIODE	
D3303	MA111-X	SI. DIODE	
TRANSISTOR			
Q3101	2SC2412K/QR/-X	SI. TRANSISTOR	
Q3102	2SA1037AK/QR/-X	SI. TRANSISTOR	
Q3103	2SC1906-T	SI. TRANSISTOR	
Q3104	2SC2412K/QR/-X	SI. TRANSISTOR	
Q3105	2SC1627A/OY/-T	SI. TRANSISTOR	
Q3108	2SA1837	POWER TRANSISTO	
Q3109	2SC4793	POWER TRANSISTO	
Q3301	2SA1037AK/QR/-X	SI. TRANSISTOR	
IC			
IC3201	TDA6111Q	I C	
IC3202	TDA6111Q	I C	
IC3203	TDA6111Q	I C	
OTHERS			
K3101	CE41492-001Z	CHOKE COIL	
K3103	CE41492-001Z	CHOKE COIL	
K3104	CE41492-001Z	CHOKE COIL	
K3105	QQR0621-002Z	FERRITE BEADS	
SG3201	QAF0056-501Z	SURGE ABSORBER	
SG3202	QAF0056-501Z	SURGE ABSORBER	
SG3203	QAF0056-501Z	SURGE ABSORBER	
△ SK3001	QNZ0464-001	CRT SOCKET	
W3003	QQR0679-001	FERRITE BEADS	
W3022	QQR0679-001	FERRITE BEADS	

■ **FRONT CONTROL P.W. BOARD ASS'Y (SMF-8405A)**

Refer to PARTS LIST in page 43 for this P.W. board.

■ **SIDE CONTROL P.W. BOARD ASS'Y (SMF-8105A)**

Symbol No.	Part No.	Part Name	Description
RESISTOR			
R8001	QRE121J-271Y	C R	270Ω 1/2W J
R8002	QRE121J-271Y	C R	270Ω 1/2W J
R8007	NRSA63J-103X	MG R	10kΩ 1/16W J
R8010	NRSA63J-103X	MG R	10kΩ 1/16W J
R8012	NRSA63J-103X	MG R	10kΩ 1/16W J
R8013	NRSA63J-103X	MG R	10kΩ 1/16W J
R8021	NRSA63J-102X	MG R	1kΩ 1/16W J
R8022	NRSA63J-102X	MG R	1kΩ 1/16W J
CAPACITOR			
C8001	NCB31HK-103X	C CAP.	0.01μF 50V K
C8002	NCB31HK-103X	C CAP.	0.01μF 50V K
C8003	NDC31HJ-680X	C CAP.	68pF 50V J
C8010	NCB31HK-472X	C CAP.	4700pF 50V K
C8011	NCB31HK-472X	C CAP.	4700pF 50V K
C8021	NCB31CK-104X	C CAP.	0.1μF 16V K
COIL			
L8001	QQR0716-001Z	FERRITE BEADS	
L8002	QQL244K-5R6Z	COIL	5.6μH K
L8003	QQL244K-5R6Z	COIL	5.6μH K
L8010	QQL244K-270Z	COIL	27μH K
L8011	QQL244K-270Z	COIL	27μH K
L8012	QQR0716-001Z	FERRITE BEADS	
DIODE			
D8010	SPR-39MVMF	LED	
D8011	MA111-X	SI DIODE	
D8014	MA3068/M/-X	ZENER DIODE	
OTHERS			
J8001	QMS3001-C01	3.5 JACK	
J8003	QNZ0438-001	AV JACK	
LC8002	NQR0169-001X	EMI FILTER	
S8001	QSW0619-003Z	TACT SWITCH	MENU
S8002	QSW0619-003Z	TACT SWITCH	CH DOWN
S8003	QSW0619-003Z	TACT SWITCH	CH UP

■ **DOLBY P.W. BOARD ASS'Y (SMF-0D401A)**

Refer to PARTS LIST in page 44 for this P.W. board.

■ **MICOM P.W. BOARD ASS'Y (SMF-0M403A)**

Refer to PARTS LIST in page 47 for this P.W. board.

■ **AV SW P.W. BOARD ASS'Y (SMF-0S402A)**

Refer to PARTS LIST in page 48 for this P.W. board.

■ **100Hz P.W. BOARD ASS'Y (SMF-0Z404A)**

Refer to PARTS LIST in page 50 for this P.W. board.

PACKING

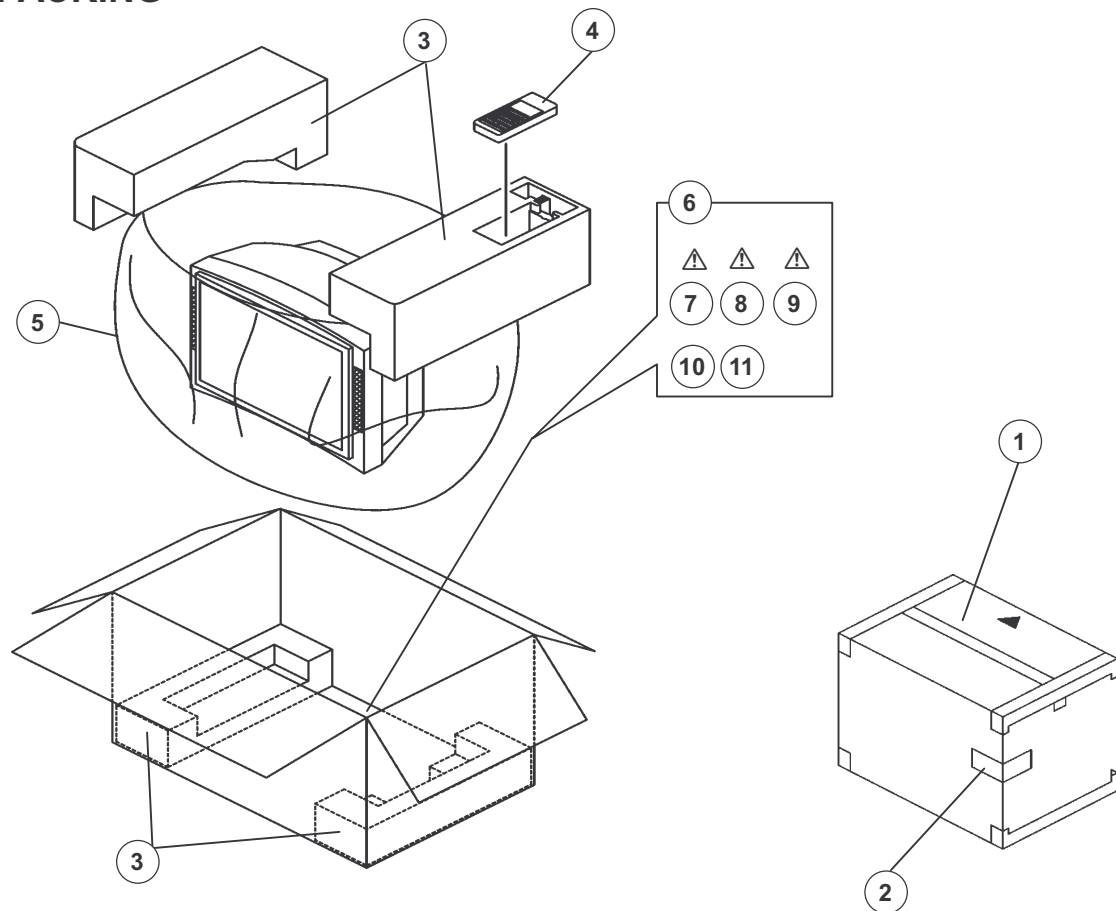

PACKING PARTS LIST

[AV-32Z25EUY]

△ Ref.No.	Part No.	Part Name	Description
1	LC10101-017A	PACKING CASE	
2	AEM1064-030-E	EURO LABEL	
3	LC11361-001C	CUSHION ASSY	4pcs in 1set
4	RM-C58H-1C	REMOCON UNIT	
5	AEM1047-A02-E	POLY BAG	
6	AEM3021-003A-E	POLY BAG	
△ 7	LCT1242-001A-U	INST BOOK	ENG/DEU/FRA/NED/CAS/ITA/POR
△ 8	LCT1243-001A-U	INST BOOK	Northern Europe
△ 9	LCT1244-001A-U	INST BOOK	Eastern Europe
10	BT-54013-4E	WARRANTY CARD	
11	2832Z25EU-HSAE	S.DIAGRAM	[ITALY EDITION]

[AV-28Z25EUY]

△ Ref.No.	Part No.	Part Name	Description
1	LC10101-016A	PACKING CASE	
2	AEM1064-031-E	EURO LABEL	
3	LC11318-002C	CUSHION ASSY	4pcs in 1set
4	RM-C58H-1C	REMOCON UNIT	
5	AEM1047-A02-E	POLY BAG	
6	AEM3021-003A-E	POLY BAG	
△ 7	LCT1242-001A-U	INST BOOK	ENG/DEU/FRA/NED/CAS/ITA/POR
△ 8	LCT1243-001A-U	INST BOOK	Northern Europe
△ 9	LCT1244-001A-U	INST BOOK	Eastern Europe
10	BT-54013-4E	WARRANTY CARD	
11	2832Z25EU-HSAE	S.DIAGRAM	[ITALY EDITION]



JVC

VICTOR COMPANY OF JAPAN, LIMITED

HOME AV NETWORK BUSINESS UNIT 12, 3-chome, Moriya-cho, Kanagawa-ku, Yokohama, Kanagawa-prefecture, 221-8528, Japan



Printed in Japan
0209 WPC
DP8061

JVC

SCHEMATIC DIAGRAMS

COLOUR TELEVISION

AV-32Z25EUY AV-28Z25EUY

BASIC CHASSIS

MF II

CD-ROM No.SML200209

InterArt
Natural Vision
T-V LINK

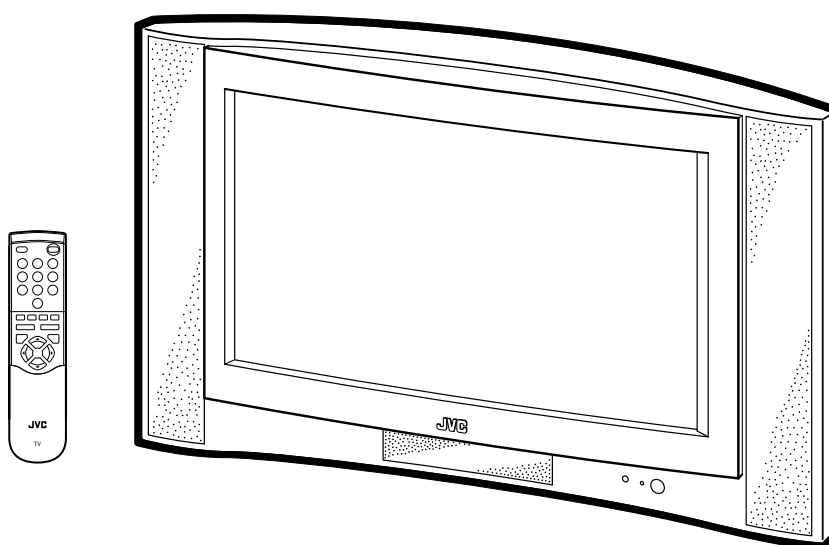

CONTENTS

■ NOTE ON USING CIRCUIT DIAGRAMS	2-1
■ SEMICONDUCTOR SHAPES	2-2
■ BLOCK DIAGRAM	2-3
■ CIRCUIT DIAGRAMS	2-5
■ PATTERN DIAGRAMS	2-25

AV-32Z25EUY / AV-28Z25EUY STANDARD CIRCUIT DIAGRAM

TOP

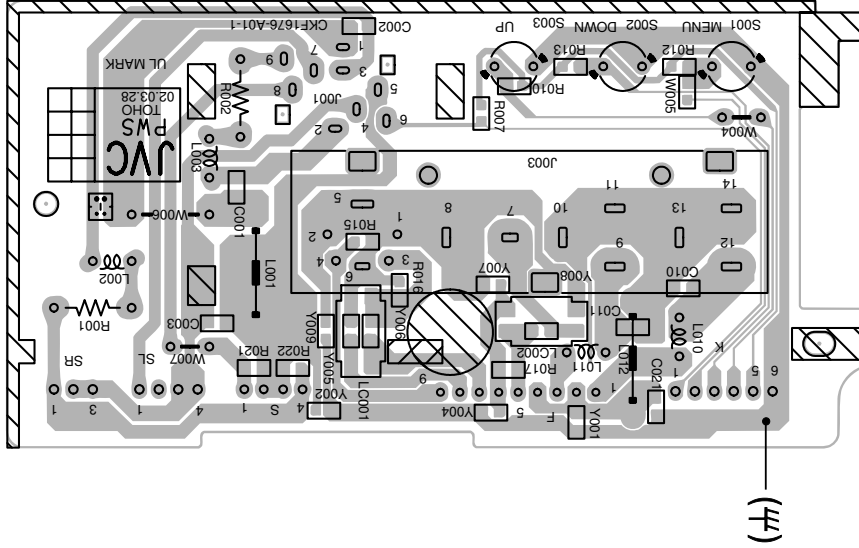

NOTE ON USING CIRCUIT DIAGRAMS

1. SAFETY

The components identified by the Δ symbol and shading are critical for safety. For continued safety replace safety critical components only with manufactures recommended parts.

2. SPECIFIED VOLTAGE AND WAVEFORM VALUES

The voltage and waveform values have been measured under the following conditions.

- (1) Input signal : Colour bar signal
- (2) Setting positions of each knob/button and variable resistor : Original setting position when shipped
- (3) Internal resistance of tester : DC 20k Ω /V
- (4) Oscilloscope sweeping time : H \Rightarrow 20 μ S/div
: V \Rightarrow 5mS/div
- (5) Voltage values : All DC voltage values
* Since the voltage values of signal circuit vary to some extent according to adjustments, use them as reference values.

3. INDICATION OF PARTS SYMBOL [EXAMPLE]

- In the PW board : R1209 \rightarrow R209

4. INDICATIONS ON THE CIRCUIT DIAGRAM

(1) Resistors

- Resistance value

- No unit { Ω }
- K {K Ω }
- M {M Ω }

● Rated allowable power

- No indication : 1/16 [W]
- Others : As specified

● Type

- No indication : Carbon resistor
- CMR : Oxide metal film resistor
- MFR : Metal film resistor
- MPR : Metal plate resistor
- UNFR : Unflammable resistor
- FR : Fusible resistor

* Composition resistor 1/2 [W] is specified as 1/2S or Comp.

(2) Capacitors

- Capacitance value

- 1 or higher : pF
- less than 1 : μ F

● Withstand voltage

- No indication : DC50[V]
- Others : DC withstand voltage [V]
- AC indicated : AC withstand voltage [V]

* Electrolytic Capacitors

47/50[Example]:Capitance value [μ F]/withstand voltage[V]

● Type

- No indication : Ceramic capacitor
- MM : Metalized mylar capacitor
- PP : Polypropylene capacitor
- MPP : Metalized polypropylene capacitor
- MF : Metalized film capacitor
- TF : Thin film capacitor
- BP : Bipolar electrolytic capacitor
- TAN : Tantalum capacitor

(3) Coils

- No unit { μ H }
- Others : As specified

(4) Power Supply

- B1 : B1
- 9V : 9V
- B2 (12V) : B2 (12V)
- 5V : 5V

* Respective voltage values are indicated

(5) Test point

- Test point : Only test point display

(6) Connecting method

- Connector : Connector
- Receptacle : Receptacle
- Wrapping or soldering : Wrapping or soldering

(7) Ground symbol

- ⊥ : LIVE side ground
- ⊥ : ISOLATED(NEUTRAL) side ground
- ⊥ : EARTH ground
- ⊥ : DIGITAL ground

5. NOTE FOR REPAIRING SERVICE

This model's power circuit is partly different in the GND. The difference of the GND is shown by the LIVE : (⊥) side GND and the ISOLATED(NEUTRAL) : (⊥) side GND. Therefore, care must be taken for the following points.

- (1) Do not touch the LIVE side GND or the LIVE side GND and the ISOLATED(NEUTRAL) side GND simultaneously. If the above caution is not respected, an electric shock may be caused. Therefore, make sure that the power cord is surely removed from the receptacle when, for example, the chassis is pulled out.
- (2) Do not short between the LIVE side GND and ISOLATED(NEUTRAL) side GND or never measure with a measuring apparatus measure with a measuring apparatus (oscilloscope, etc.) the LIVE side GND and ISOLATED(NEUTRAL) side GND at the same time. If the above precaution is not respected, a fuse or any parts will be broken.

◇ Since the circuit diagram is a standard one, the circuit and circuit constants may be subject to change for improvement without any notice.

NOTE

- ◇ Due to improvement in performance, some part numbers show in the circuit diagram may not agree with those indicated in the part list.
- When ordering parts, please use the numbers that appear in the Parts List.

CONTENTS

SEMICONDUCTOR SHAPES	2-2
BLOCK DIAGRAM	2-3
CIRCUIT DIAGRAMS	
MAIN PWB CIRCUIT DIAGRAM	2-5
POWER & DEF. PWB CIRCUIT DIAGRAM	2-9
AV SW PWB CIRCUIT DIAGRAM	2-11
MICOM PWB CIRCUIT DIAGRAM	2-13
100Hz PWB CIRCUIT DIAGRAM	2-15
CRT SOCKET PWB CIRCUIT DIAGRAM	2-17
FRONT CONTROL PWB CIRCUIT DIAGRAM	2-19
SIDE CONTROL PWB CIRCUIT DIAGRAM	2-20
DOLBY PWB CIRCUIT DIAGRAM	2-21
PATTERN DIAGRAMS	
MAIN PWB PATTERN	2-25
POWER & DEF. PWB PATTERN	2-29
AV SW PWB PATTERN	2-31
CRT SOCKET PWB PATTERN	2-32
MICOM PWB PATTERN	2-33
100Hz PWB PATTERN	2-35
DOLBY PWB PATTERN	2-37
FRONT CONTROL PWB PATTERN	2-39
SIDE CONTROL PWB PATTERN	2-40

FRONT CONTROL PWB PATTERN

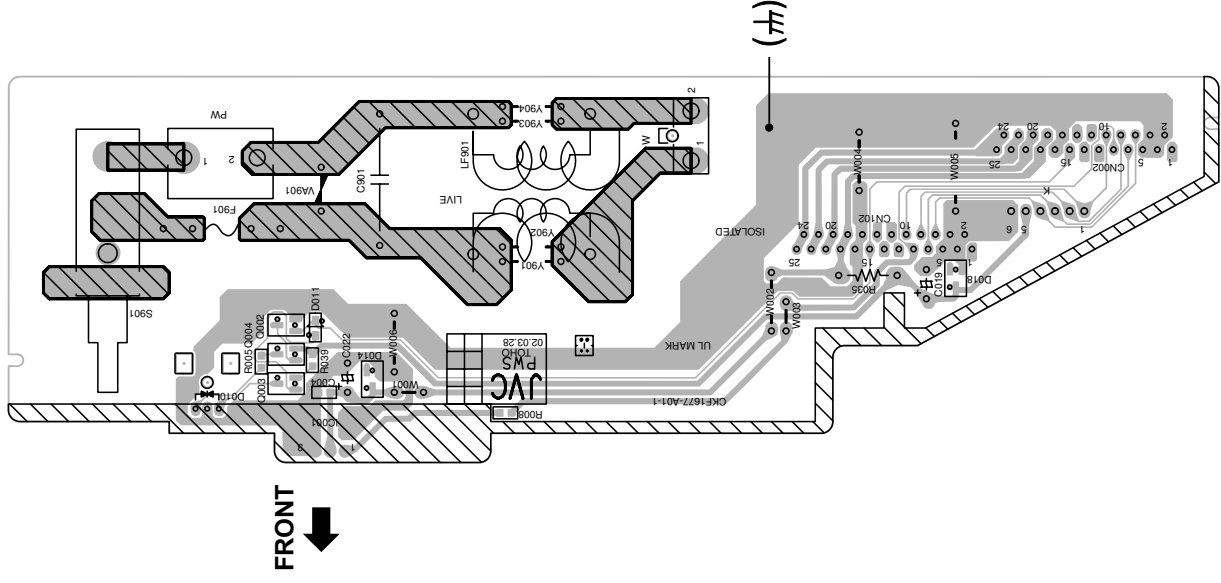

SEMICONDUCTOR SHAPES

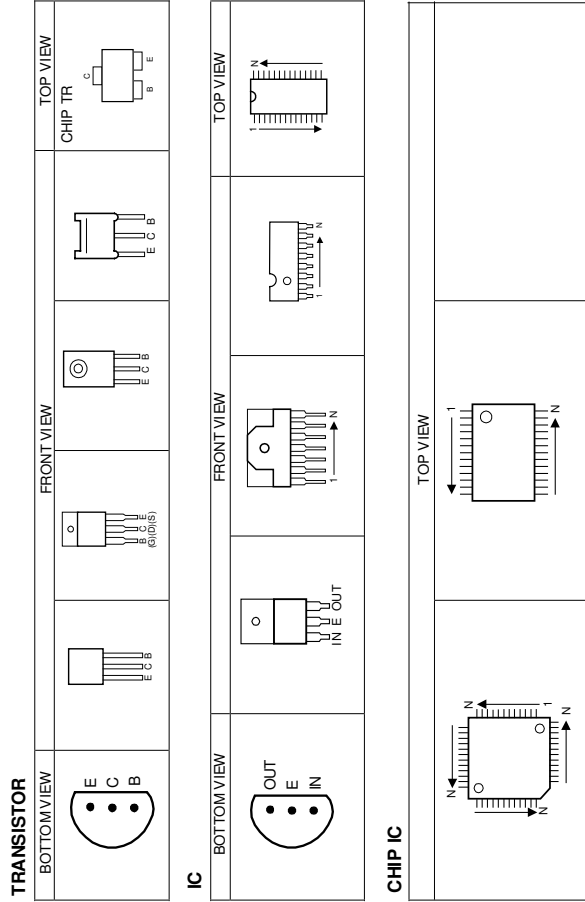

AV-32Z25EUY
AV-28Z25EUY

AV-32Z25EUY
AV-28Z25EUY

CIRCUIT DIAGRAMS MAIN PWB CIRCUIT DIAGRAM [1/2]

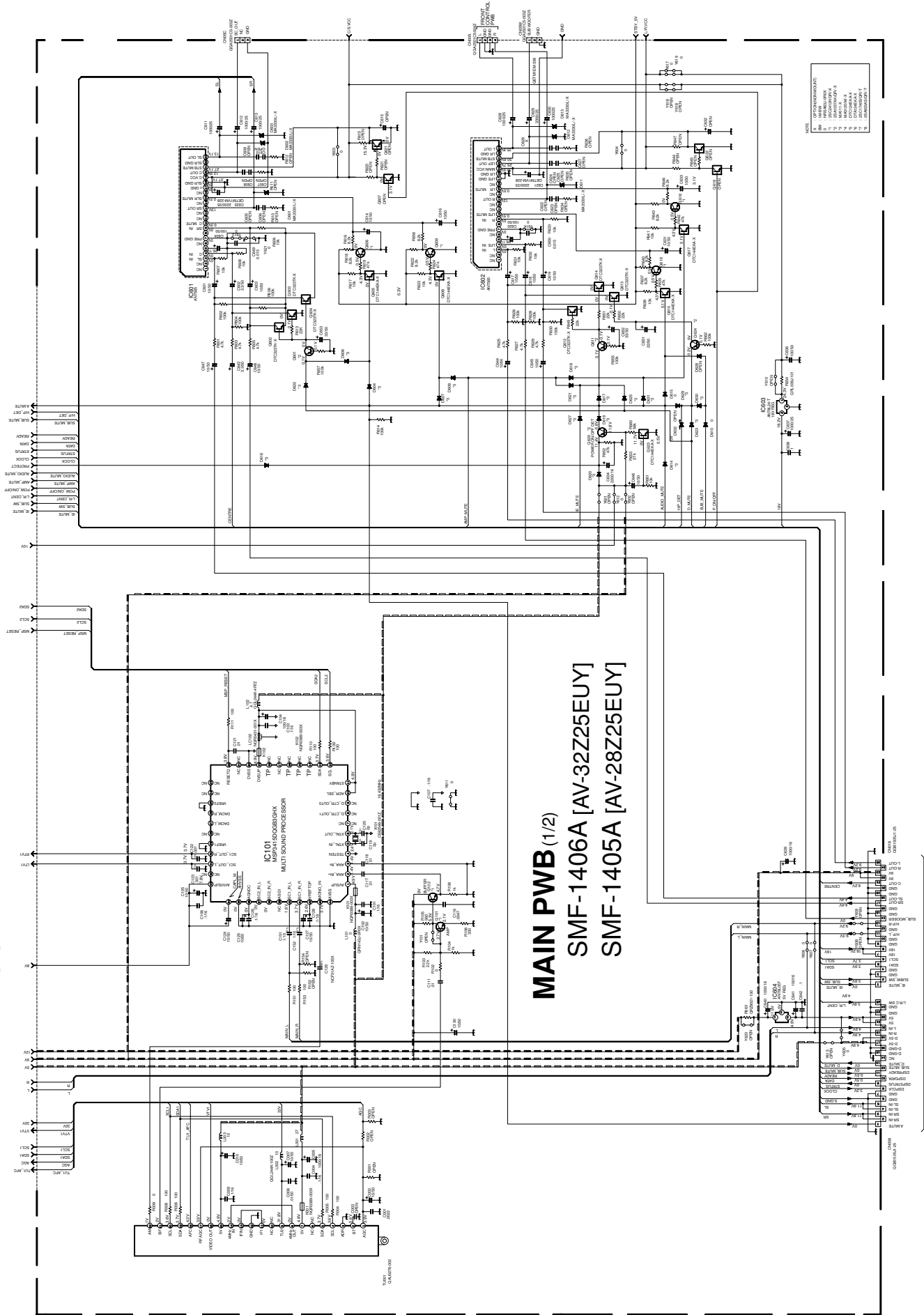

MAIN PWB (1/2)
SMF-1406A [AV-32Z25EUY]
SMF-1405A [AV-28Z25EUY]

MAIN PWB CIRCUIT DIAGRAM [2/2]

AV-3225EUY
AV-2825EUY

AV-3225EUY
AV-2825EUY

100% PWB

MICON PWB

AV SWPWB

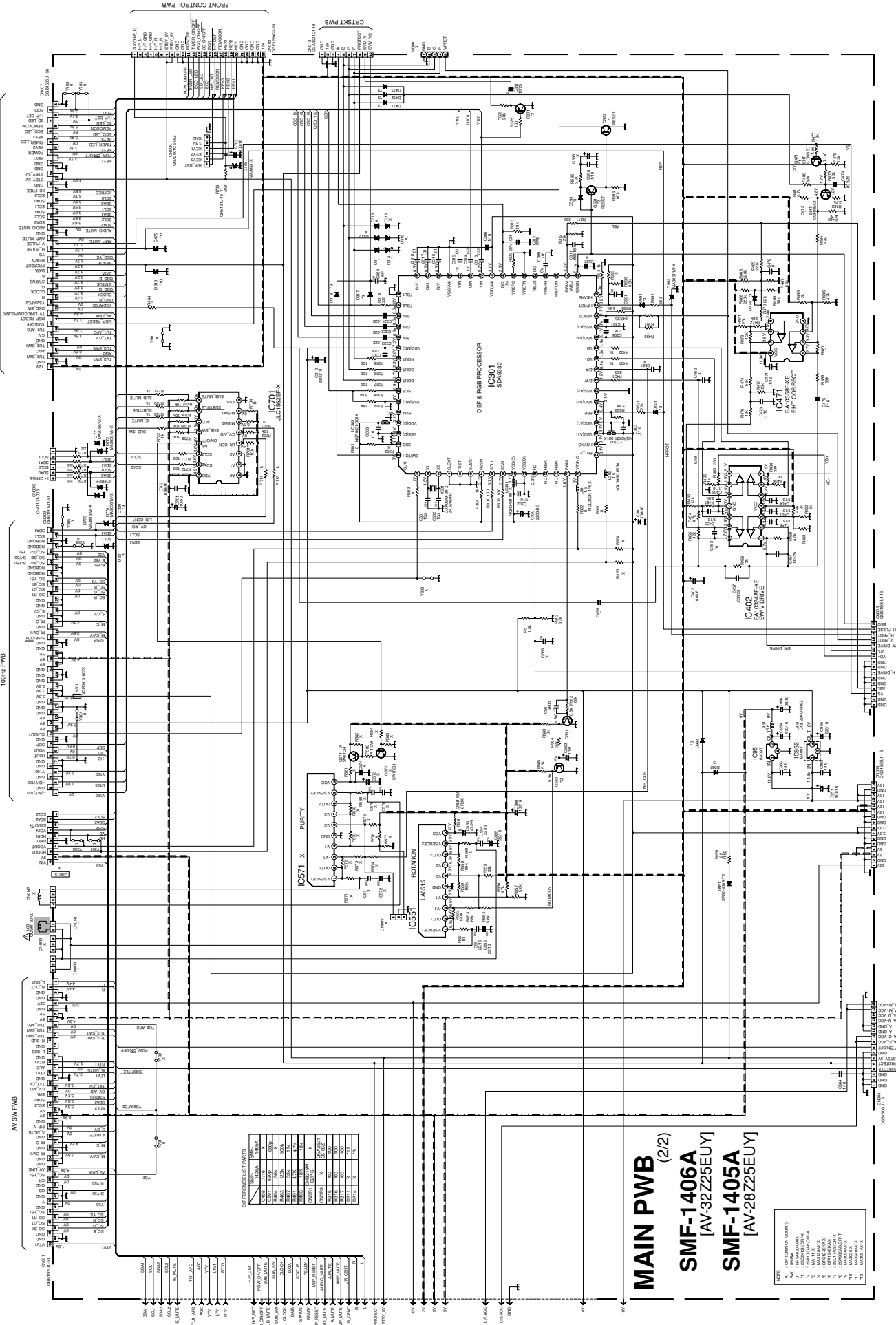

DIFFERENCE LIST PRINTS

REV	DESCRIPTION	DATE
1	INITIAL	10/10/80
2	REVISED	10/10/80
3	REVISED	10/10/80
4	REVISED	10/10/80
5	REVISED	10/10/80
6	REVISED	10/10/80
7	REVISED	10/10/80
8	REVISED	10/10/80
9	REVISED	10/10/80
10	REVISED	10/10/80
11	REVISED	10/10/80
12	REVISED	10/10/80

MAIN PWB (2/2)
SMF-1406A
[AV-3225EUY]
SMF-1405A
[AV-2825EUY]

- NOTE: (CONTINUED FROM PAGE 1)
1. DIMENSIONS IN MILLIMETERS
 2. DIMENSIONS IN INCHES
 3. DIMENSIONS IN MILLIMETERS
 4. DIMENSIONS IN INCHES
 5. DIMENSIONS IN MILLIMETERS
 6. DIMENSIONS IN INCHES
 7. DIMENSIONS IN MILLIMETERS
 8. DIMENSIONS IN INCHES
 9. DIMENSIONS IN MILLIMETERS
 10. DIMENSIONS IN INCHES
 11. DIMENSIONS IN MILLIMETERS
 12. DIMENSIONS IN INCHES

POW & DEF. PWB

POWER & DEF. PWB CIRCUIT DIAGRAM

AV-32Z25EUY
AV-28Z25EUY

AV-32Z25EUY
AV-28Z25EUY

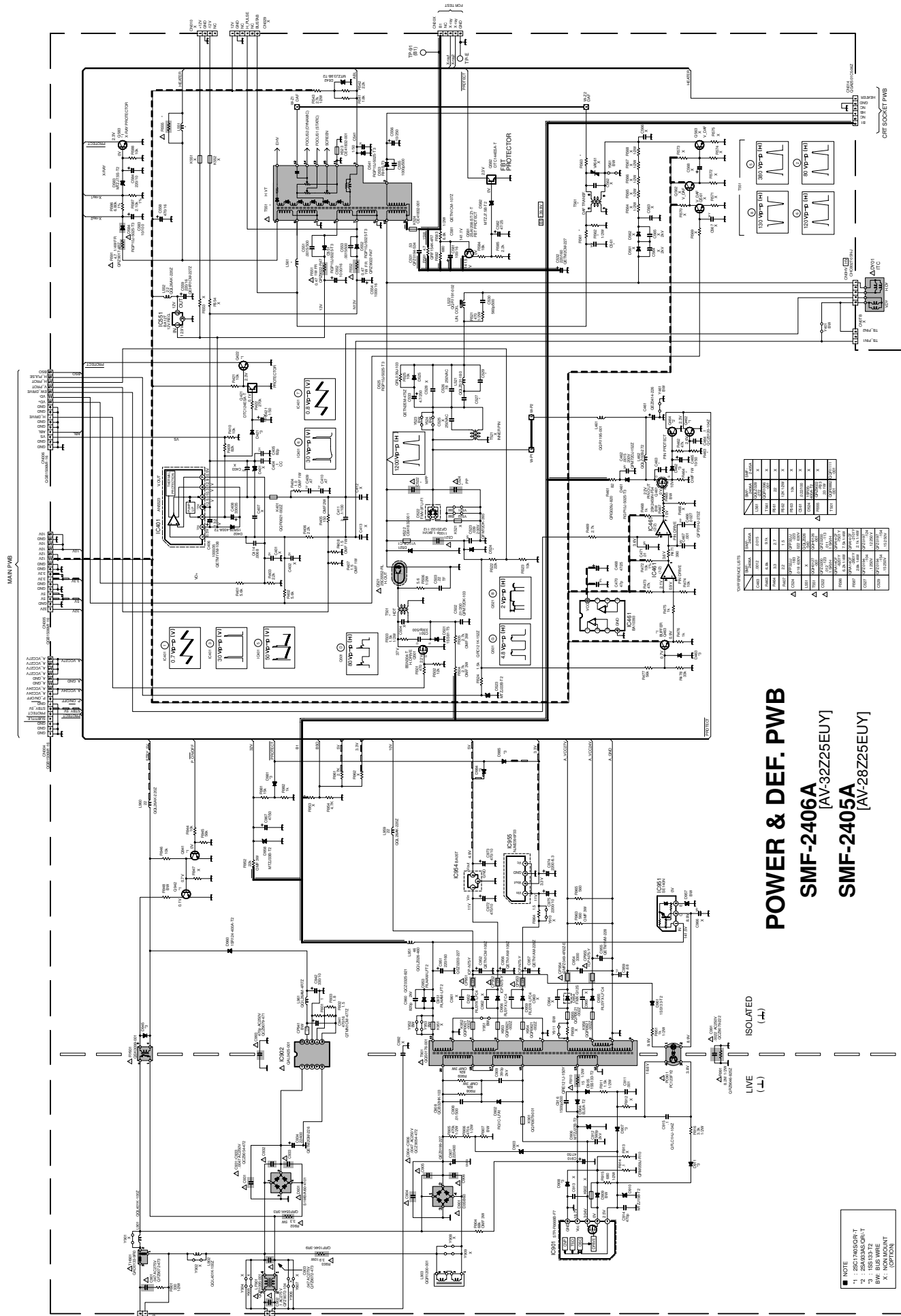

VOLTAGE LEVELS

MEASUREMENT	MEASUREMENT	MEASUREMENT	MEASUREMENT
LINE	LINE	LINE	LINE
...

POWER & DEF. PWB
SMF-2406A
[AV-32Z25EUY]
SMF-2405A
[AV-28Z25EUY]

NOTE
1 : 2502 FABRICANT
2 : 15S13372
3 : 15S13372
BW: BUS WIRE
X : OPTION
/ : OPTION

LIVE (L)
ISOLATED (I)

AV SW PWB SMF-0S402A

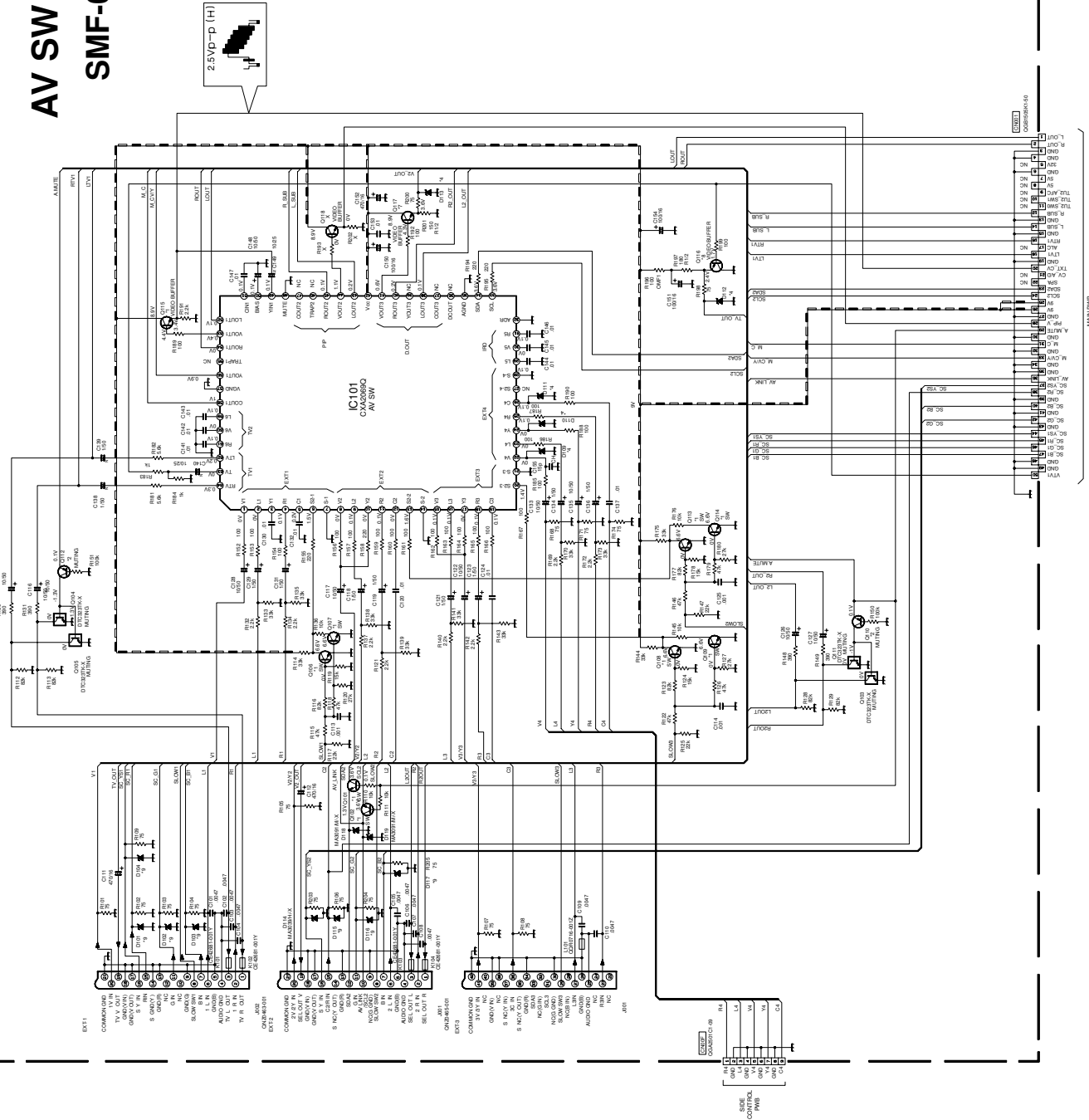

AV-32Z25EUY
AV-28Z25EUY

AV-32Z25EUY
AV-28Z25EUY

MICOM PWB CIRCUIT DIAGRAM

MICOM PWB
SMF-0M403A

- NOTE:
- 1. 2827/AVOX
 - 2. 2827/AVOX
 - 3. 2827/AVOX
 - 4. 2827/AVOX
 - 5. 2827/AVOX
 - 6. 2827/AVOX
 - 7. 2827/AVOX
 - 8. 2827/AVOX
 - 9. 2827/AVOX
 - 10. 2827/AVOX
 - 11. 2827/AVOX
 - 12. 2827/AVOX
 - 13. 2827/AVOX
 - 14. 2827/AVOX
 - 15. 2827/AVOX
 - 16. 2827/AVOX
 - 17. 2827/AVOX
 - 18. 2827/AVOX
 - 19. 2827/AVOX
 - 20. 2827/AVOX
 - 21. 2827/AVOX
 - 22. 2827/AVOX
 - 23. 2827/AVOX
 - 24. 2827/AVOX
 - 25. 2827/AVOX
 - 26. 2827/AVOX
 - 27. 2827/AVOX
 - 28. 2827/AVOX
 - 29. 2827/AVOX
 - 30. 2827/AVOX
 - 31. 2827/AVOX
 - 32. 2827/AVOX
 - 33. 2827/AVOX
 - 34. 2827/AVOX
 - 35. 2827/AVOX
 - 36. 2827/AVOX
 - 37. 2827/AVOX
 - 38. 2827/AVOX
 - 39. 2827/AVOX
 - 40. 2827/AVOX
 - 41. 2827/AVOX
 - 42. 2827/AVOX
 - 43. 2827/AVOX
 - 44. 2827/AVOX
 - 45. 2827/AVOX
 - 46. 2827/AVOX
 - 47. 2827/AVOX
 - 48. 2827/AVOX
 - 49. 2827/AVOX
 - 50. 2827/AVOX
 - 51. 2827/AVOX
 - 52. 2827/AVOX
 - 53. 2827/AVOX
 - 54. 2827/AVOX
 - 55. 2827/AVOX
 - 56. 2827/AVOX
 - 57. 2827/AVOX
 - 58. 2827/AVOX
 - 59. 2827/AVOX
 - 60. 2827/AVOX
 - 61. 2827/AVOX
 - 62. 2827/AVOX
 - 63. 2827/AVOX
 - 64. 2827/AVOX
 - 65. 2827/AVOX
 - 66. 2827/AVOX
 - 67. 2827/AVOX
 - 68. 2827/AVOX
 - 69. 2827/AVOX
 - 70. 2827/AVOX
 - 71. 2827/AVOX
 - 72. 2827/AVOX
 - 73. 2827/AVOX
 - 74. 2827/AVOX
 - 75. 2827/AVOX
 - 76. 2827/AVOX
 - 77. 2827/AVOX
 - 78. 2827/AVOX
 - 79. 2827/AVOX
 - 80. 2827/AVOX
 - 81. 2827/AVOX
 - 82. 2827/AVOX
 - 83. 2827/AVOX
 - 84. 2827/AVOX
 - 85. 2827/AVOX
 - 86. 2827/AVOX
 - 87. 2827/AVOX
 - 88. 2827/AVOX
 - 89. 2827/AVOX
 - 90. 2827/AVOX
 - 91. 2827/AVOX
 - 92. 2827/AVOX
 - 93. 2827/AVOX
 - 94. 2827/AVOX
 - 95. 2827/AVOX
 - 96. 2827/AVOX
 - 97. 2827/AVOX
 - 98. 2827/AVOX
 - 99. 2827/AVOX
 - 100. 2827/AVOX
- X OPEN
O CHIP IS WIRE

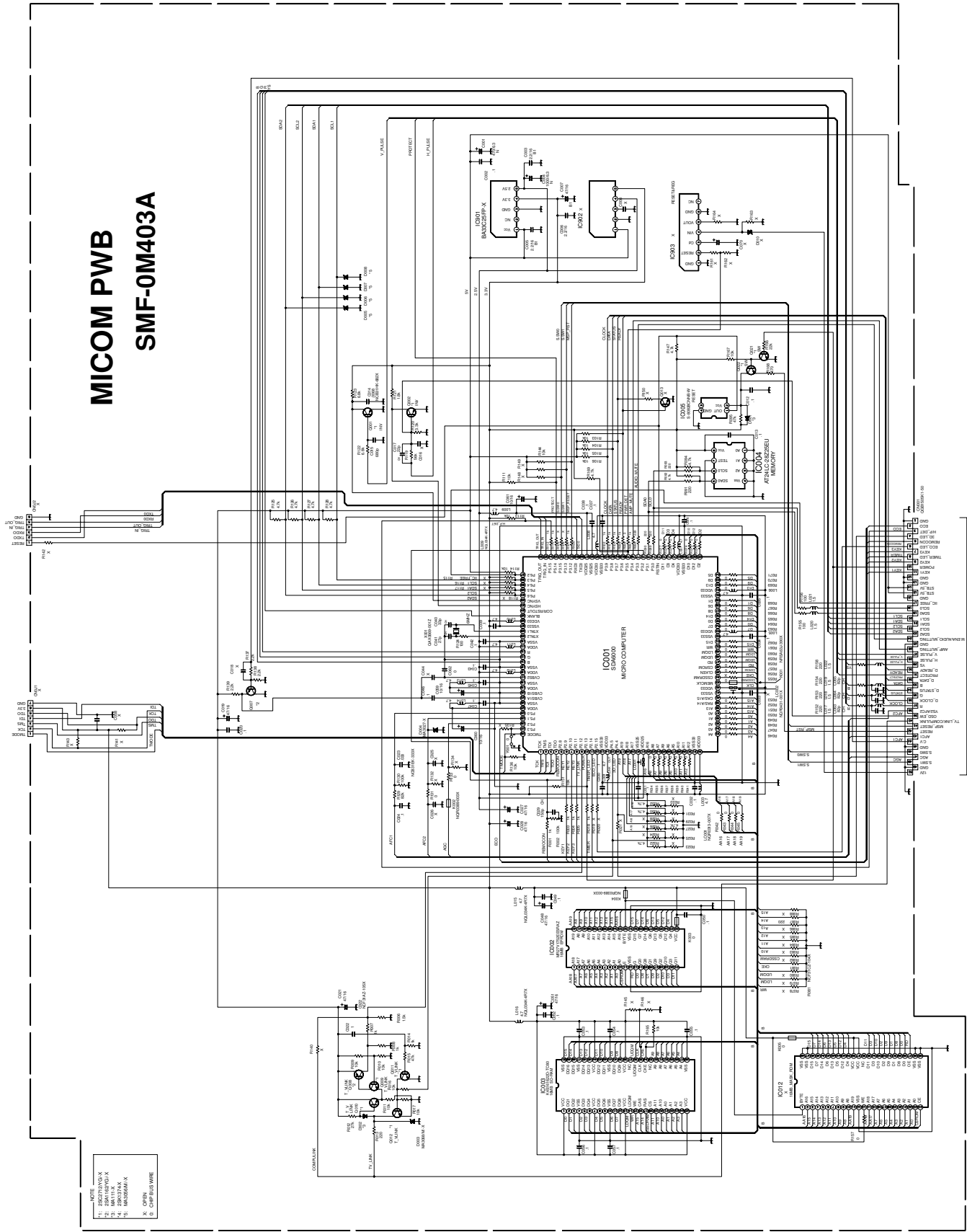

100Hz PWB CIRCUIT DIAGRAM

AV-32Z25EUY
AV-28Z25EUY

AV-32Z25EUY
AV-28Z25EUY

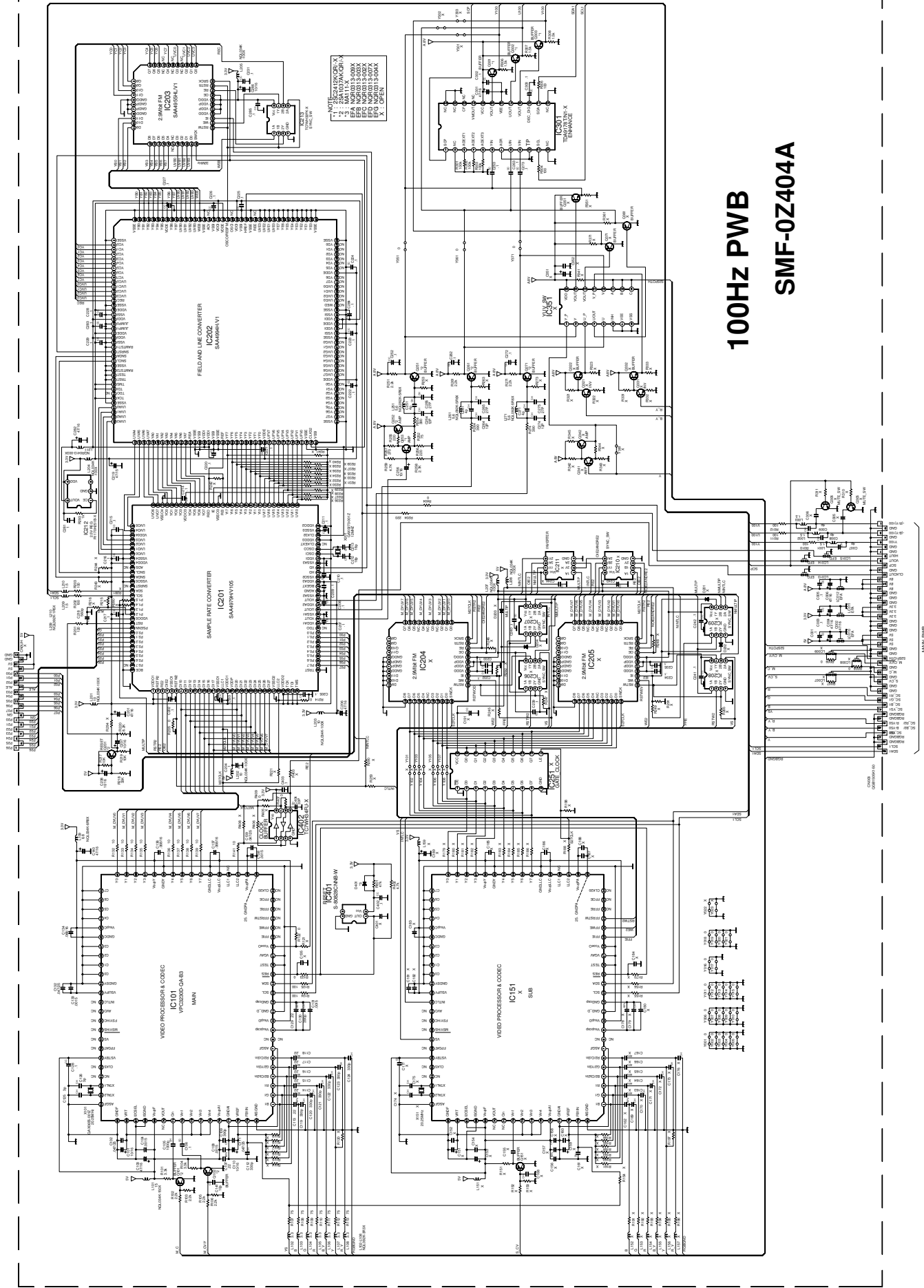

100Hz PWB
SMF-0Z404A

100Hz PWB

2-16

2-15

No.52067

No.52067

CRT SOCKET PWB CIRCUIT DIAGRAM

CRT SOCKET PWB

SMF-3406A
[AV-32Z25EUY]

SMF-3407A
[AV-28Z25EUY]

AV-32Z25EUY
AV-28Z25EUY

AV-32Z25EUY
AV-28Z25EUY

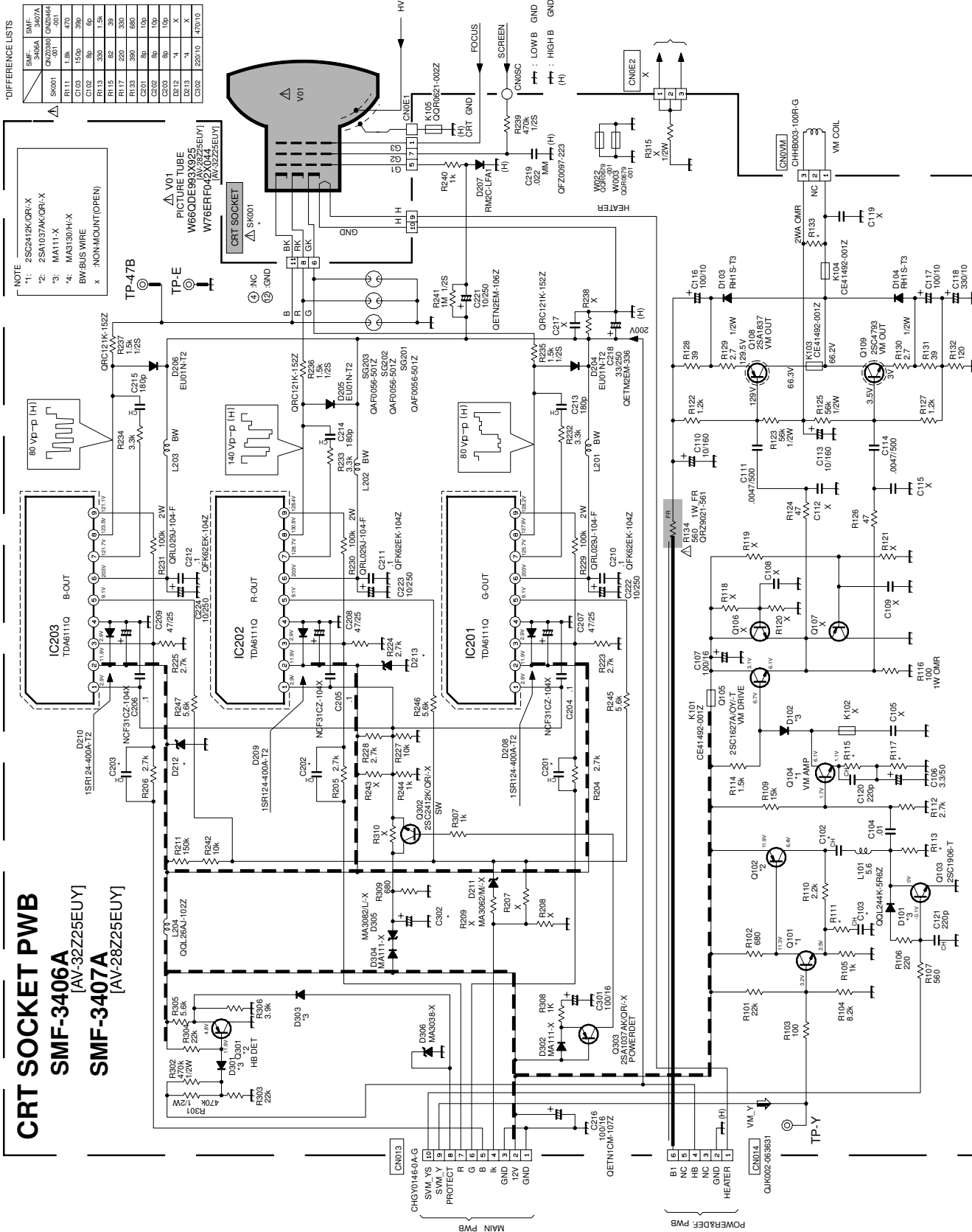

DIFFERENCE LISTS

SMF-3406A	SMF-3407A
SK001	ON001
RI11	1.8k
RI12	1.5k
RI13	330
RI14	82
RI15	330
RI16	220
RI17	220
RI18	820
RI19	330
RI20	82
RI21	10k
RI22	1k
RI23	1k
RI24	1k
RI25	1k
RI26	1k
RI27	1k
RI28	1k
RI29	1k
RI30	1k
RI31	1k
RI32	1k
RI33	1k
RI34	1k
RI35	1k
RI36	1k
RI37	1k
RI38	1k
RI39	1k
RI40	1k
RI41	1k
RI42	1k
RI43	1k
RI44	1k
RI45	1k
RI46	1k
RI47	1k
RI48	1k
RI49	1k
RI50	1k
RI51	1k
RI52	1k
RI53	1k
RI54	1k
RI55	1k
RI56	1k
RI57	1k
RI58	1k
RI59	1k
RI60	1k
RI61	1k
RI62	1k
RI63	1k
RI64	1k
RI65	1k
RI66	1k
RI67	1k
RI68	1k
RI69	1k
RI70	1k
RI71	1k
RI72	1k
RI73	1k
RI74	1k
RI75	1k
RI76	1k
RI77	1k
RI78	1k
RI79	1k
RI80	1k
RI81	1k
RI82	1k
RI83	1k
RI84	1k
RI85	1k
RI86	1k
RI87	1k
RI88	1k
RI89	1k
RI90	1k
RI91	1k
RI92	1k
RI93	1k
RI94	1k
RI95	1k
RI96	1k
RI97	1k
RI98	1k
RI99	1k
RI100	1k

NOTE
 1: 2SC2412K(OR)-X
 2: 2SA1037AK(OR)-X
 3: MA111-X
 4: MA3130/H-X
 BW:BUS WIRE
 X :NON-MOUNT(OPEN)

FRONT CONTROL PWB CIRCUIT DIAGRAM

FRONT CONTROL PWB
SMF-8405A

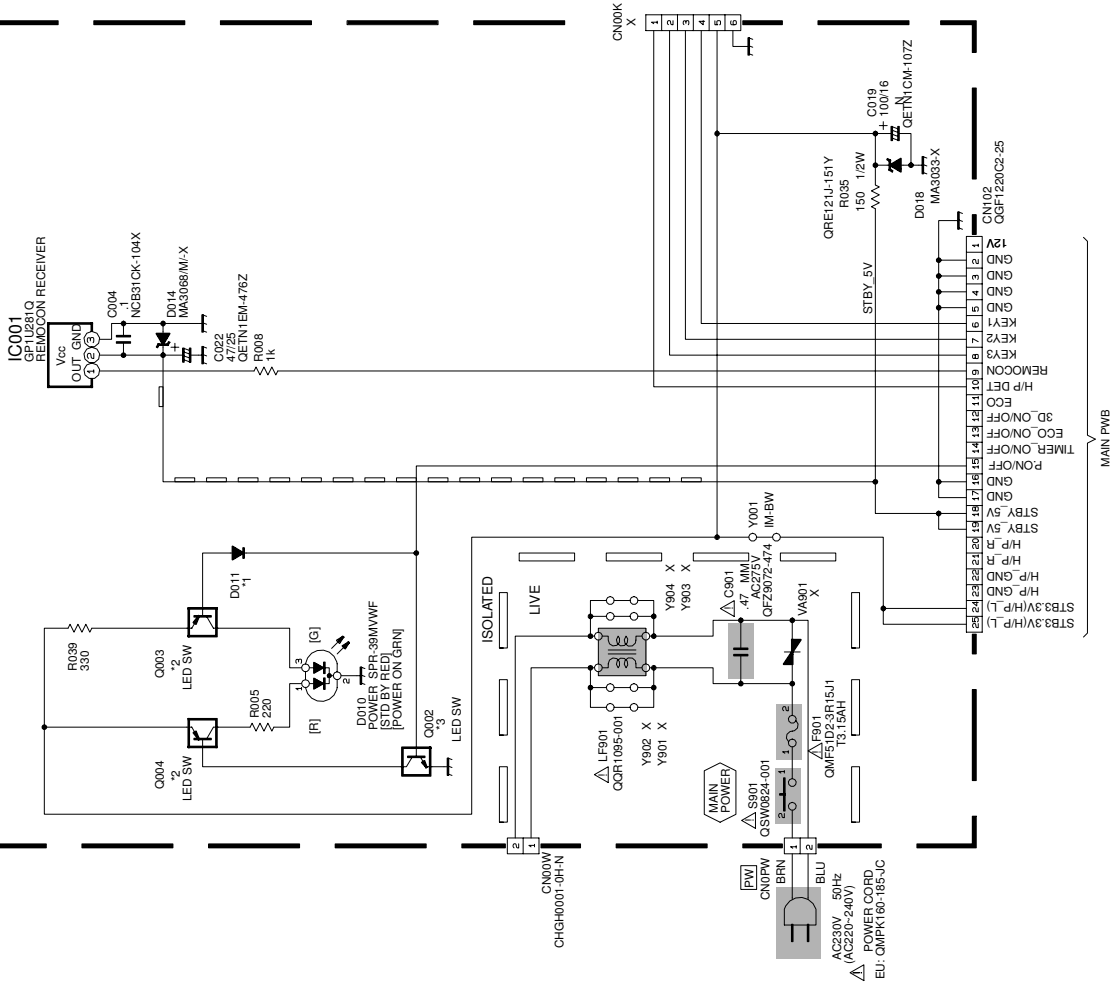

SIDE CONTROL PWB CIRCUIT DIAGRAM

SIDE CONTROL PWB

SMF-8106A [AV-32Z25EUY]
SMF-8105A [AV-28Z25EUY]

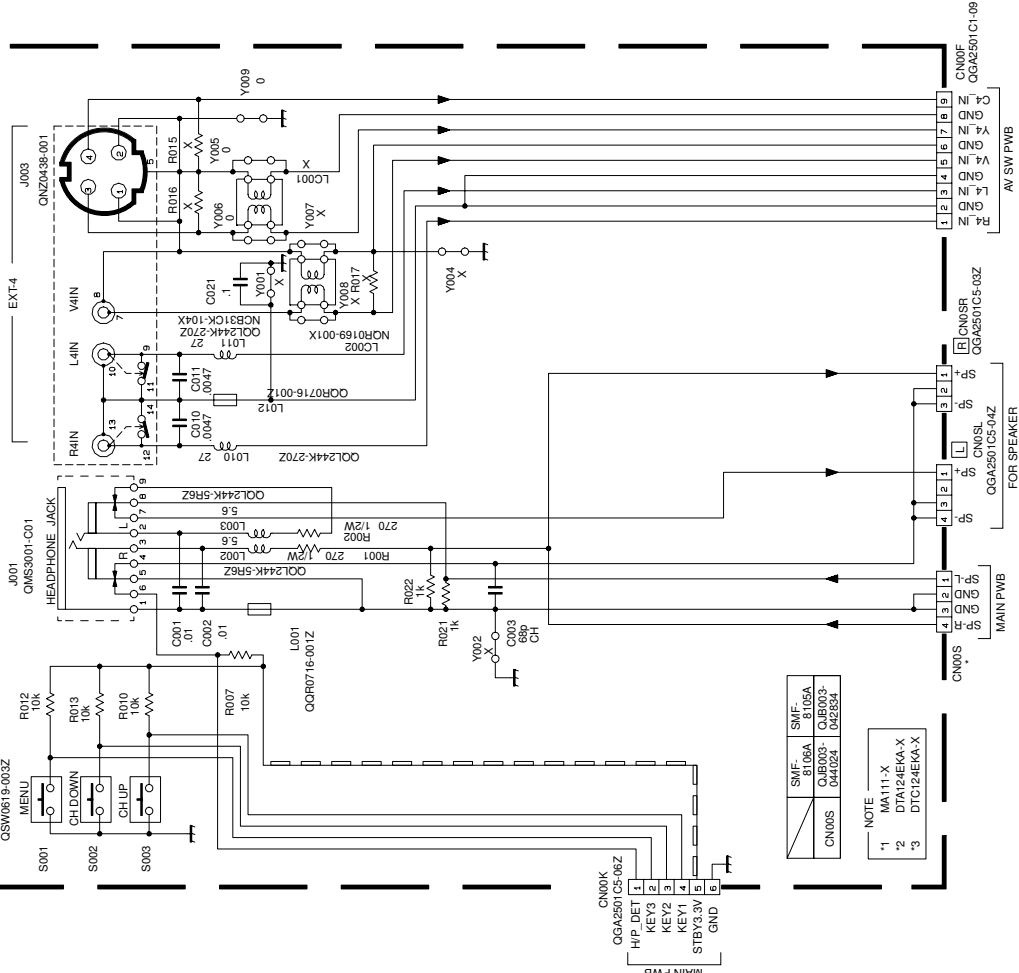

DOLBY PWB SMF-0D401A (1/2)

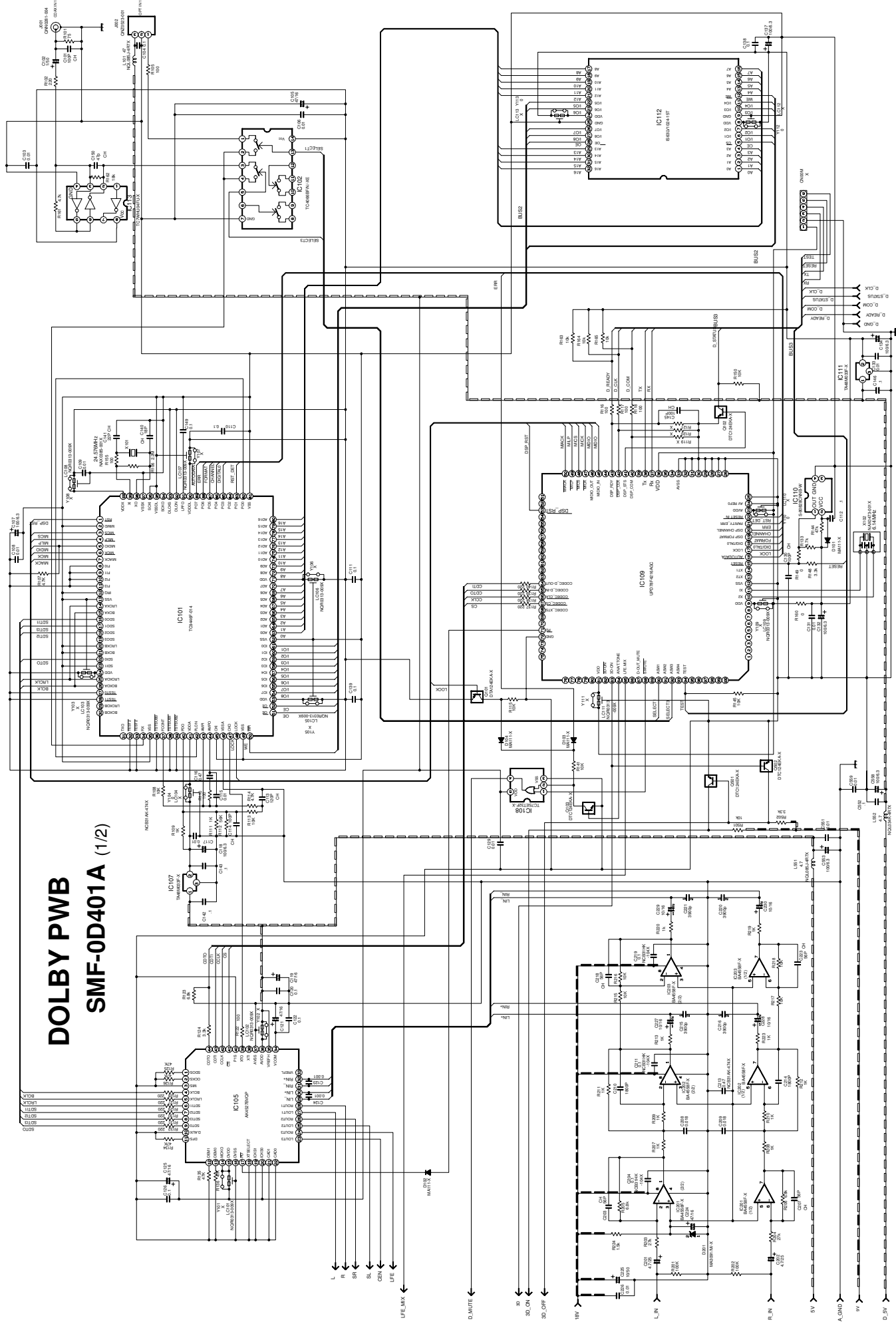

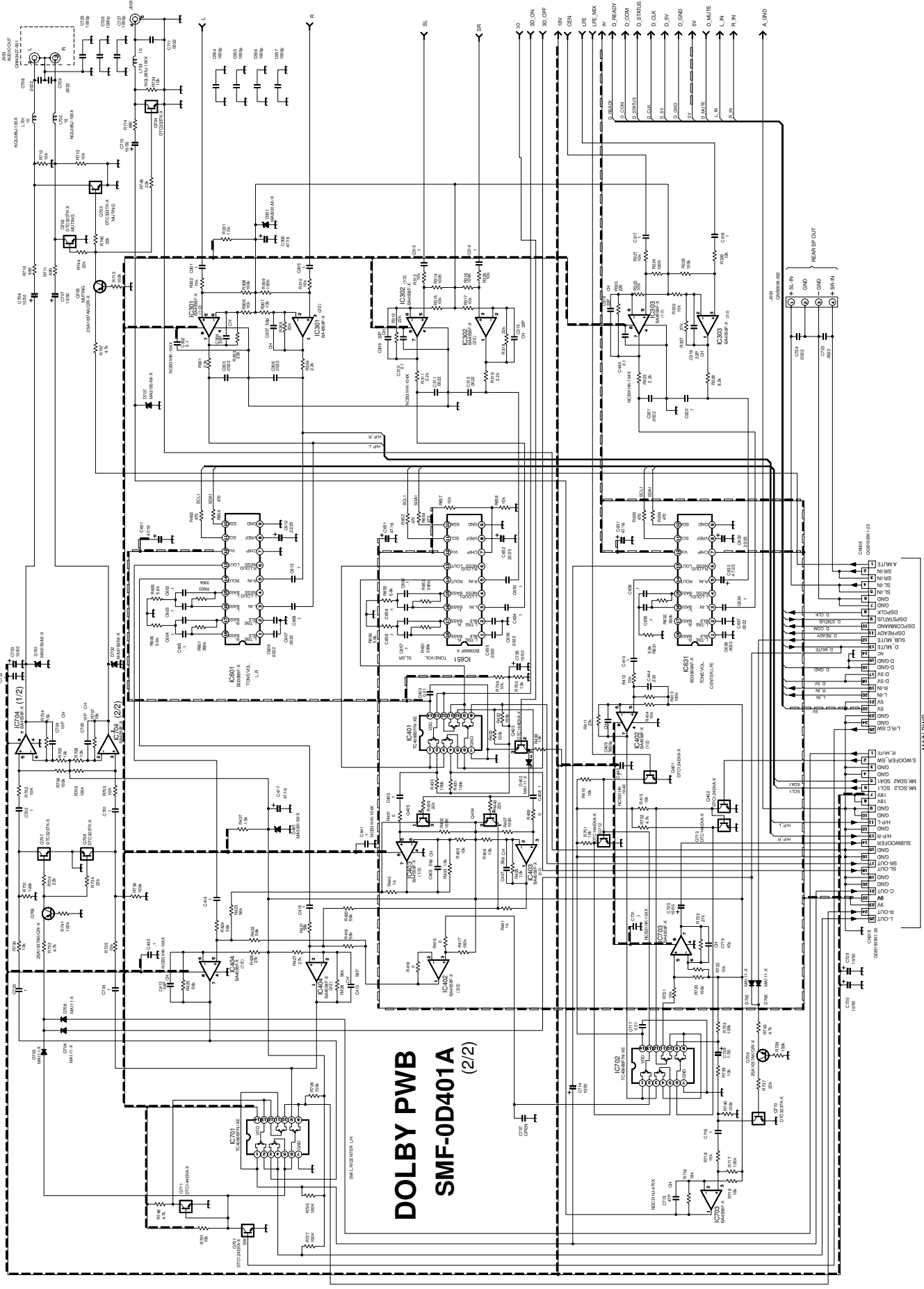

AV-32Z25EUY
AV-28Z25EUY

AV-32Z25EUY
AV-28Z25EUY

PATTERN DIAGRAMS MAIN PWB PATTERN [SOLDER SIDE]

FRONT
←

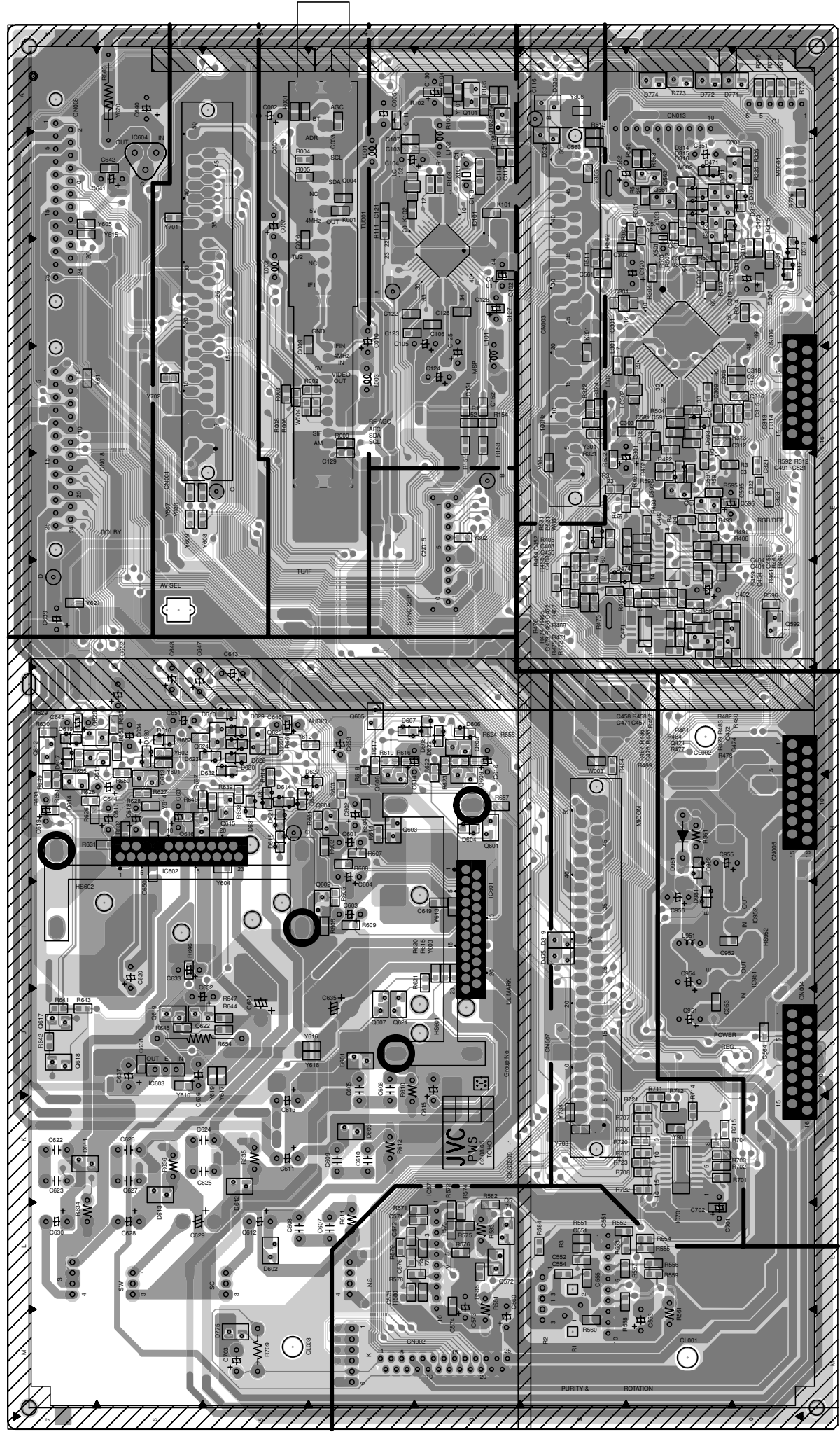

AV-32Z25EUY
AV-28Z25EUY

AV-32Z25EUY
AV-28Z25EUY

FRONT 

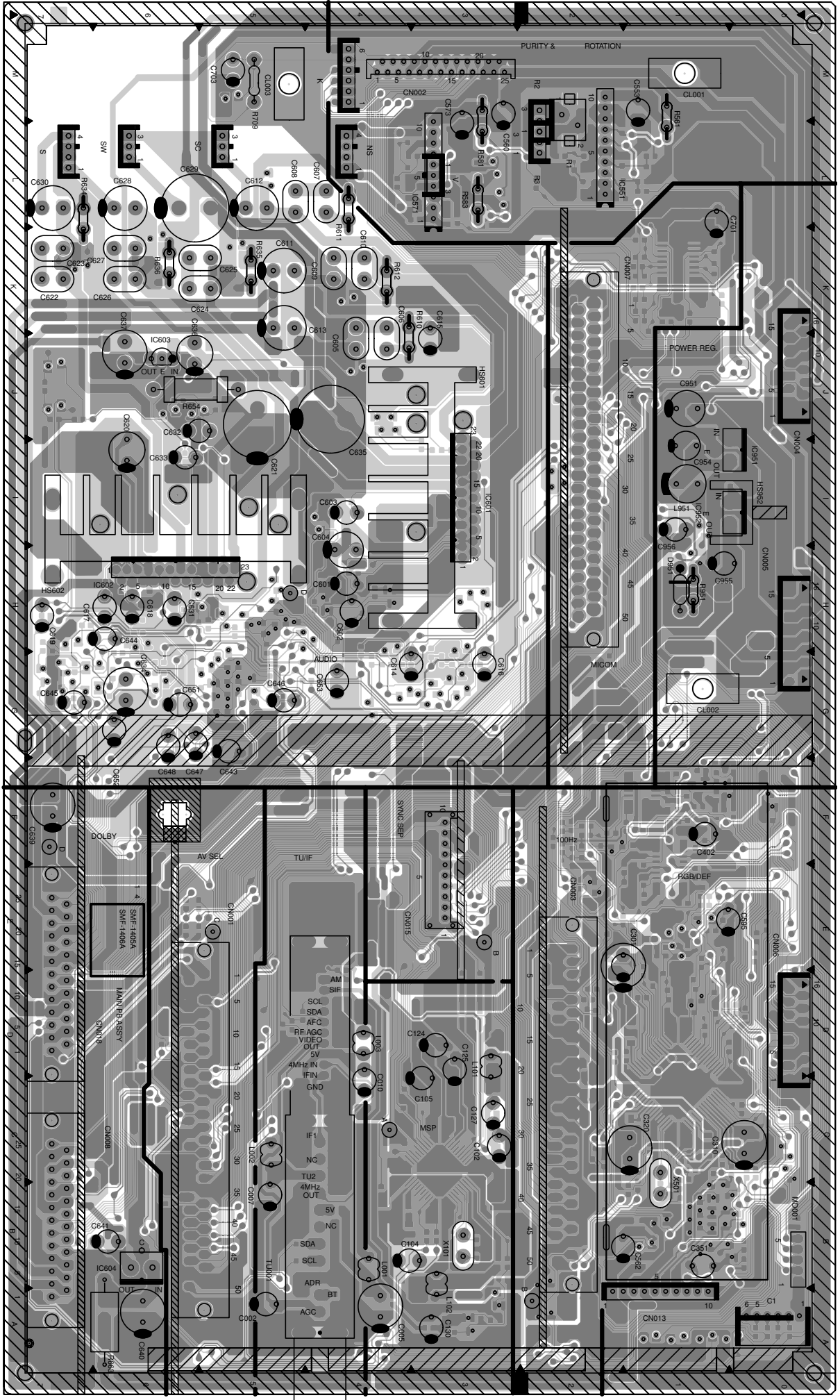

AV-32Z25EU
AV-28Z25EU

AV-32Z25EU
AV-28Z25EU

POWER & DEF. PWB PATTERN

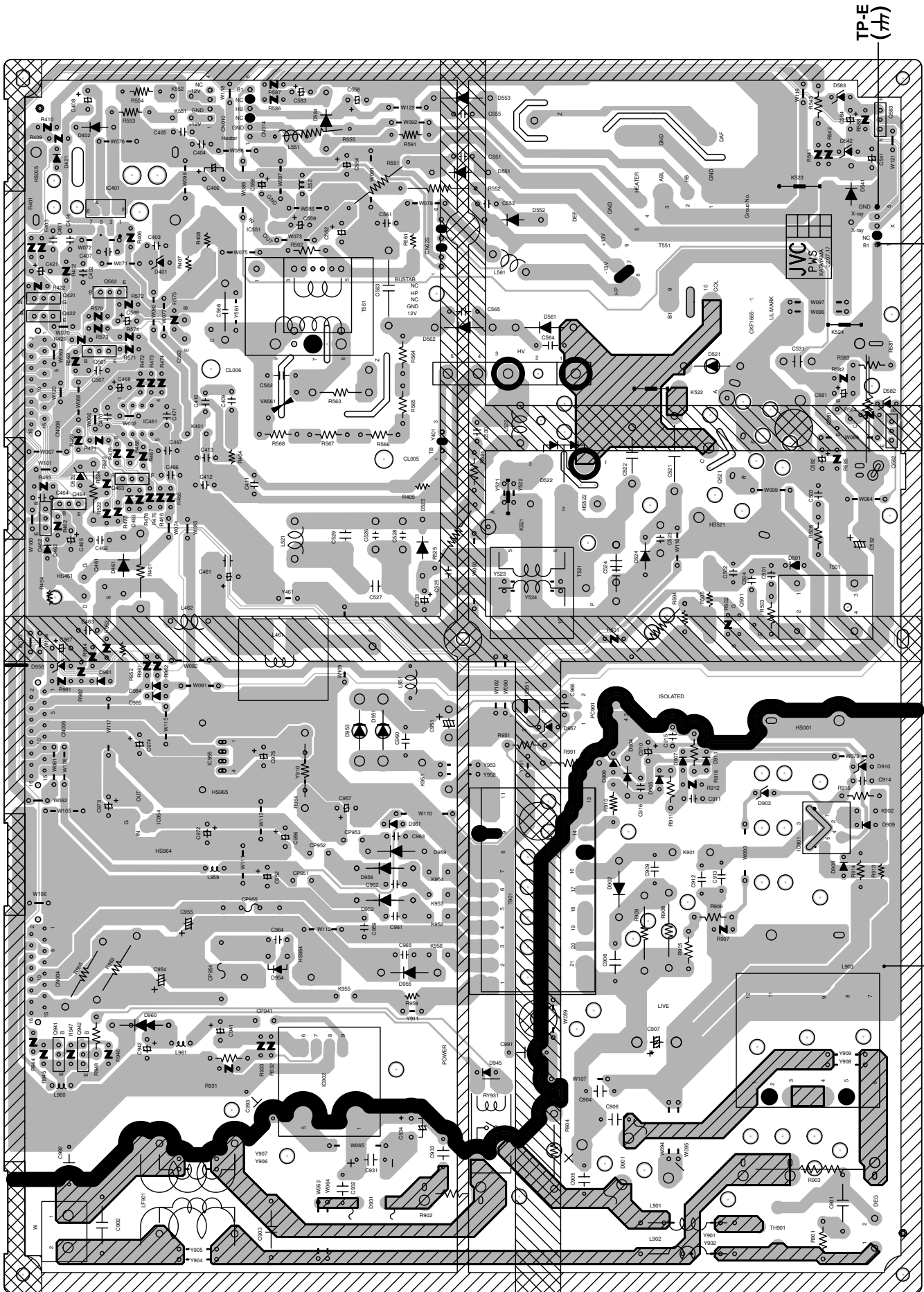

FRONT
↓

TP-E (H)

TP-91 (B1)

No.52067

2-30

2-29

(L)

No.52067

CRT SOCKET PWB PATTERN

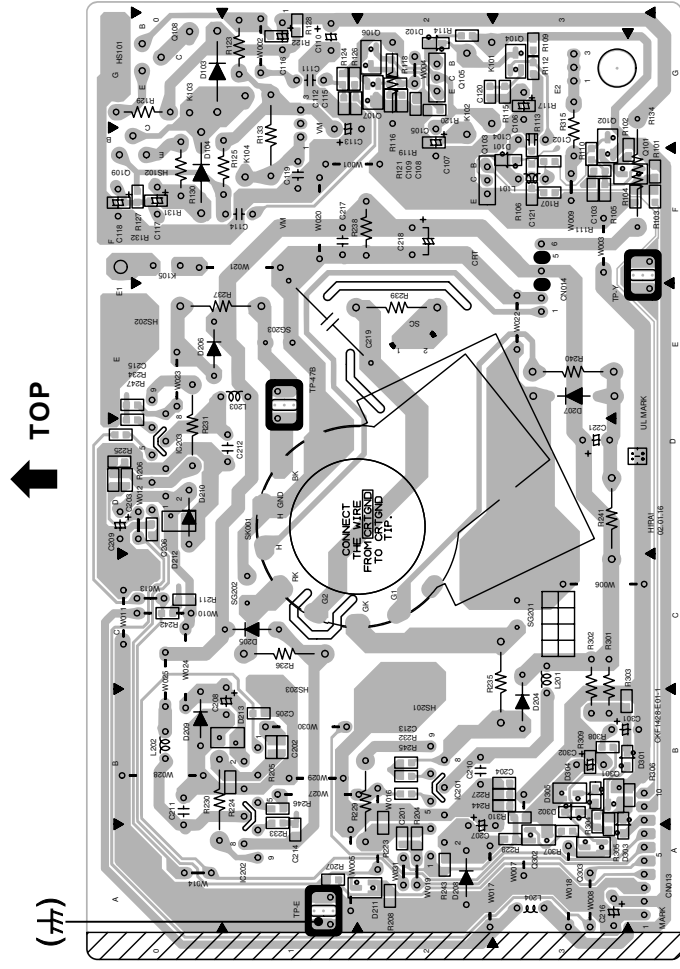

AV SW PWB PATTERN

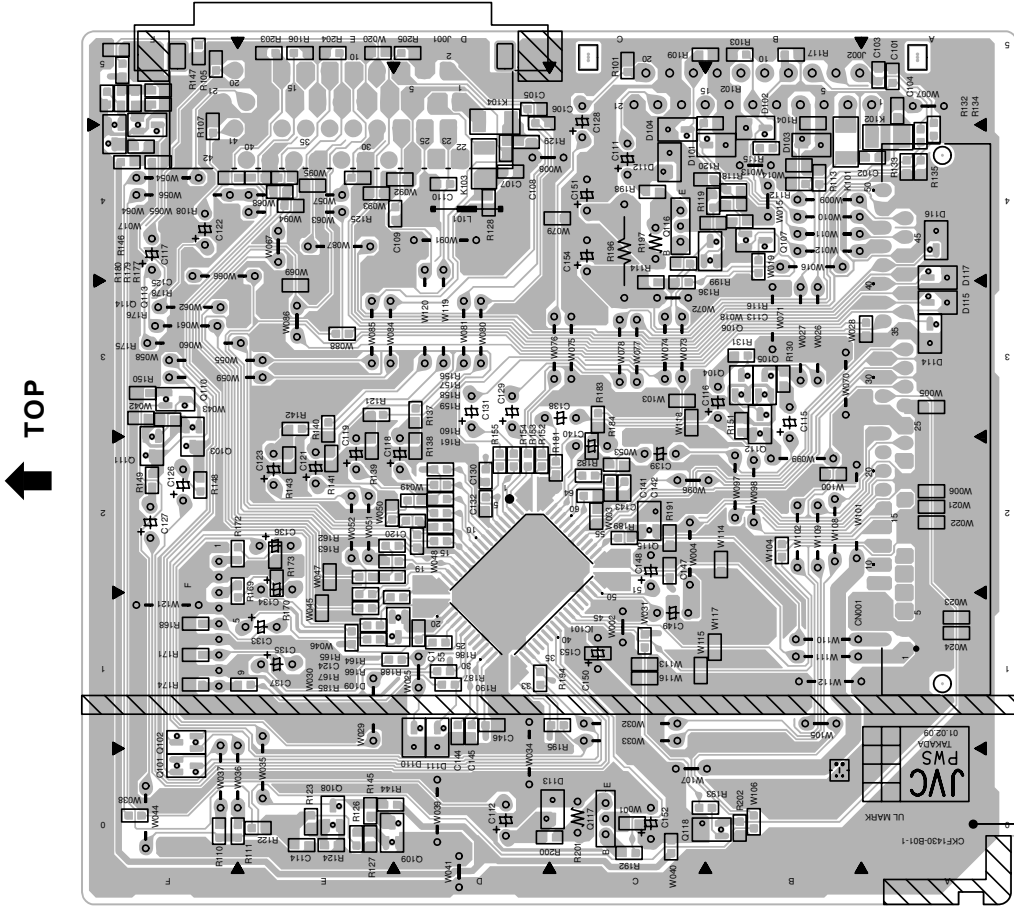

AV-32Z25EUY
AV-28Z25EUY

AV-32Z25EUY
AV-28Z25EUY

MICOM PWB PATTERN

[SOLDER SIDE]

TOP

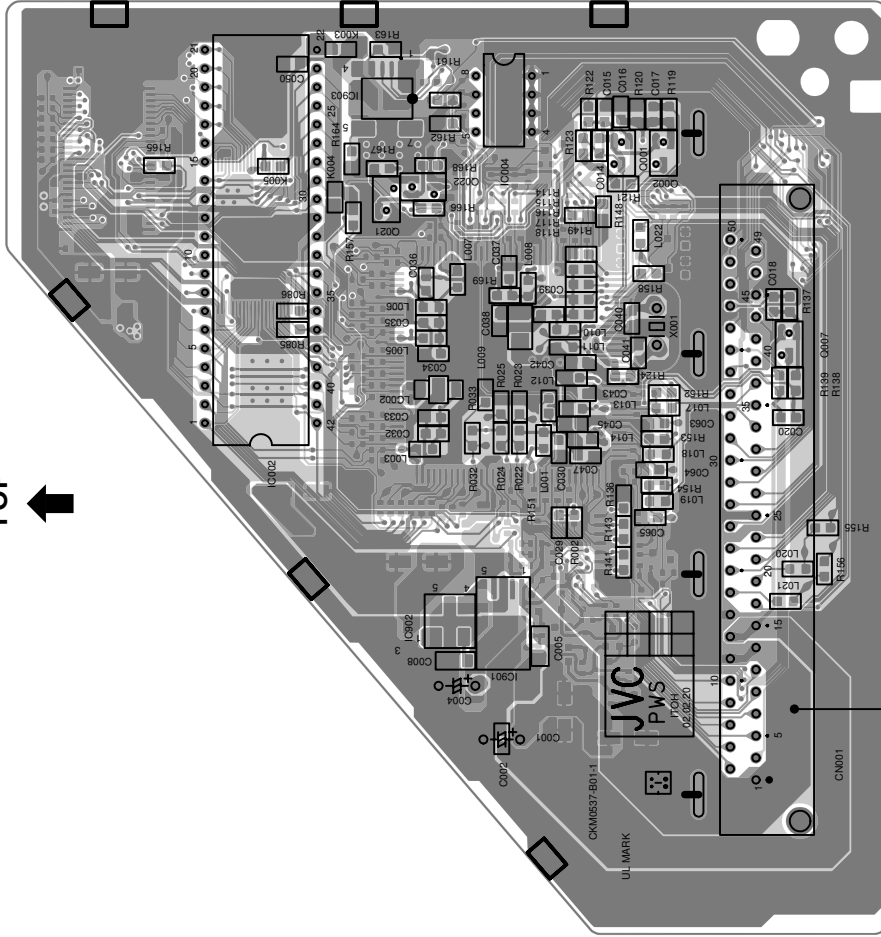

(77)

[PARTS SIDE]

TOP

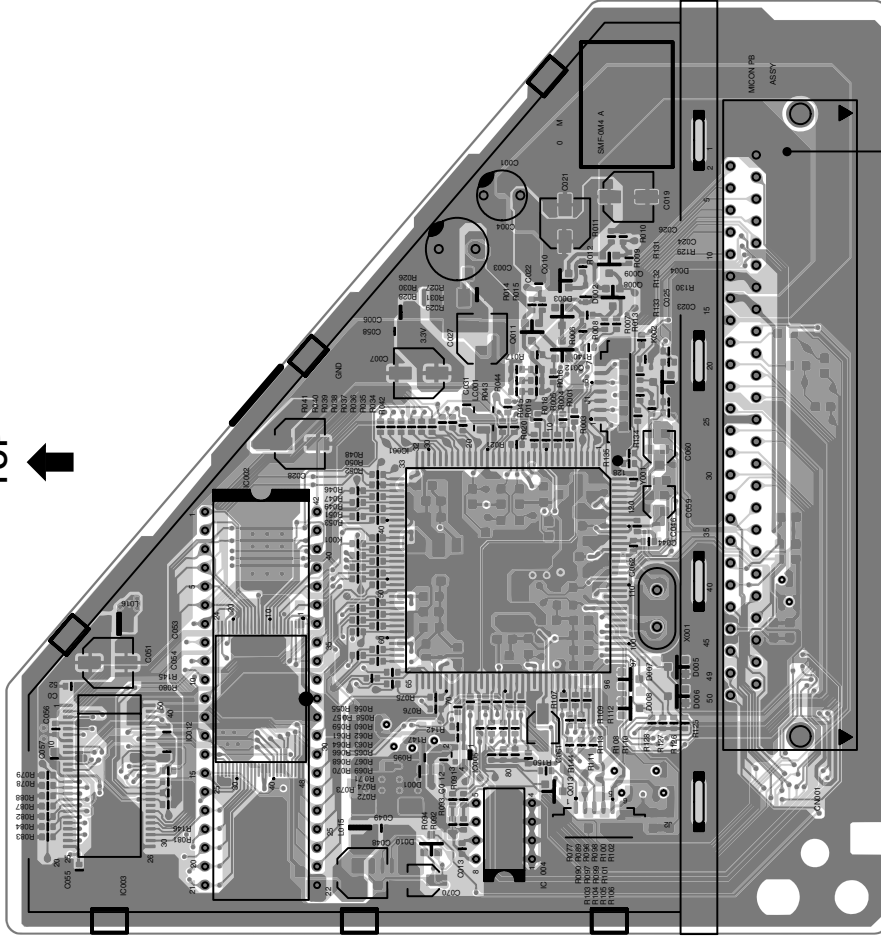

(77)

100Hz PWB PATTERN

AV-32Z25EUY
AV-28Z25EUY

AV-32Z25EUY
AV-28Z25EUY

[SOLDER SIDE]

TOP 

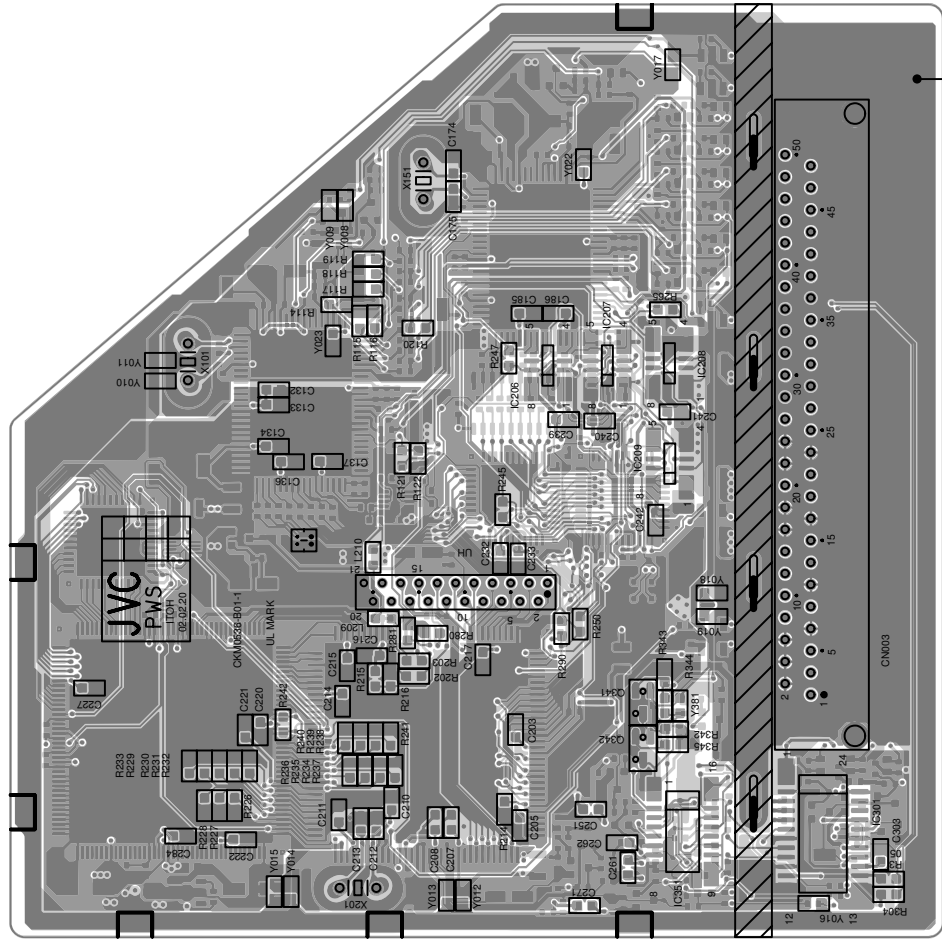

(77)

[PARTS SIDE]

TOP 

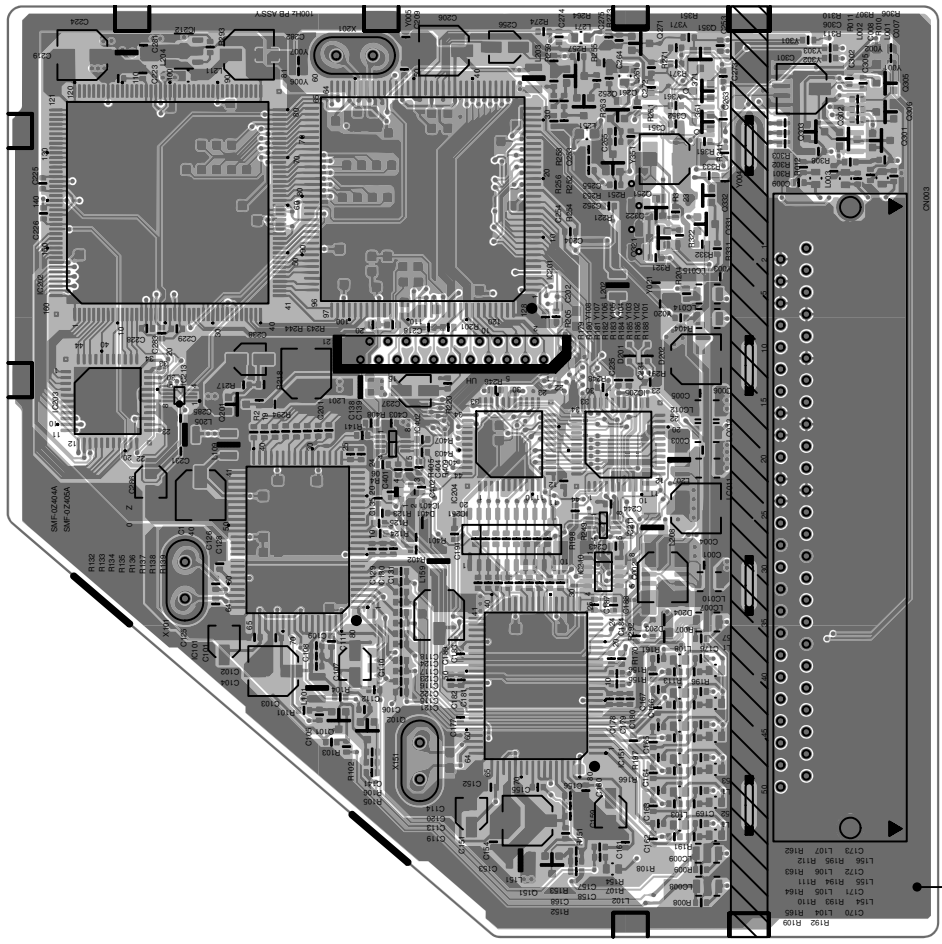

(77)

DOLBY PWB PATTERN

AV-32Z25EUY
AV-28Z25EUY

AV-32Z25EUY
AV-28Z25EUY

[SOLDER SIDE]

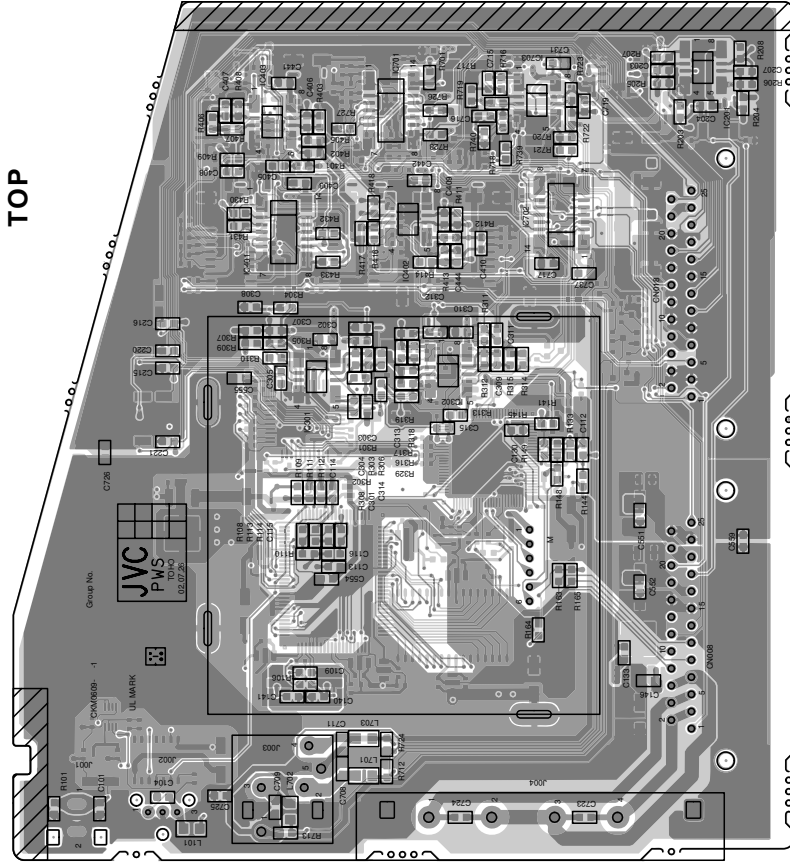

[PARTS SIDE]

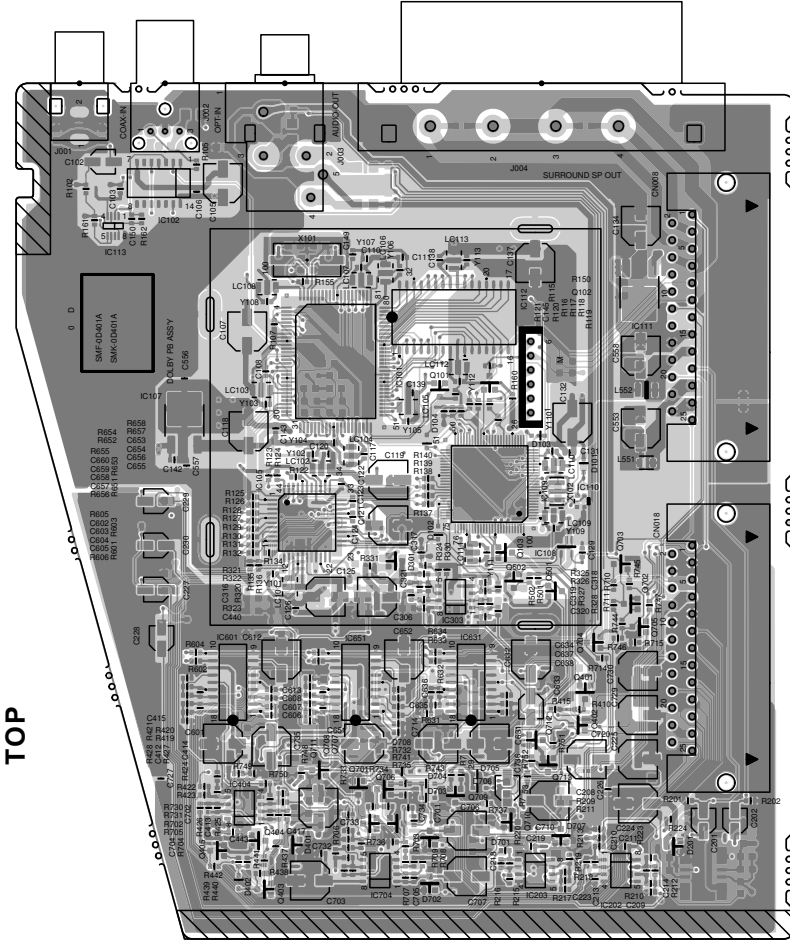

JVC

VICTOR COMPANY OF JAPAN, LIMITED

HOME AV NETWORK BUSINESS UNIT. 12, 3-chome, Moriya-cho, Kanagawa-ku, Yokohama, Kanagawa-prefecture, 221-8528, Japan



Printed in Japan
0209 WPC
DP6060

JVC

SERVICE MANUAL

COLOUR TELEVISION

BASIC CHASSIS

MF II

AV-32Z25EUY AV-28Z25EUY

Supplementary

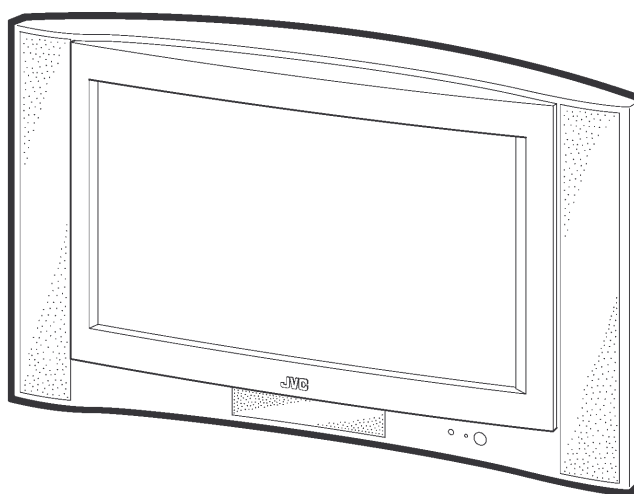

InteriArt
Natural Vision
T-V LINK

Since some details of the AV-32Z25EUY/AV-28Z25EUY SERVICE MANUAL (No.52067, Sep. 2002) which were previously revised are incorrect, we are informing you of these errors and providing you with the new descriptions given below.

CONTENTS

- STANDARD CIRCUIT DIAGRAM (REPLACEMENT) 2
- CHANGED ITEMS 3
- PARTS LIST 3

STANDARD CIRCUIT DIAGRAM (REPLACEMENT)

FRONT CONTROL PWB CIRCUIT DIAGRAM (Page 2-19)

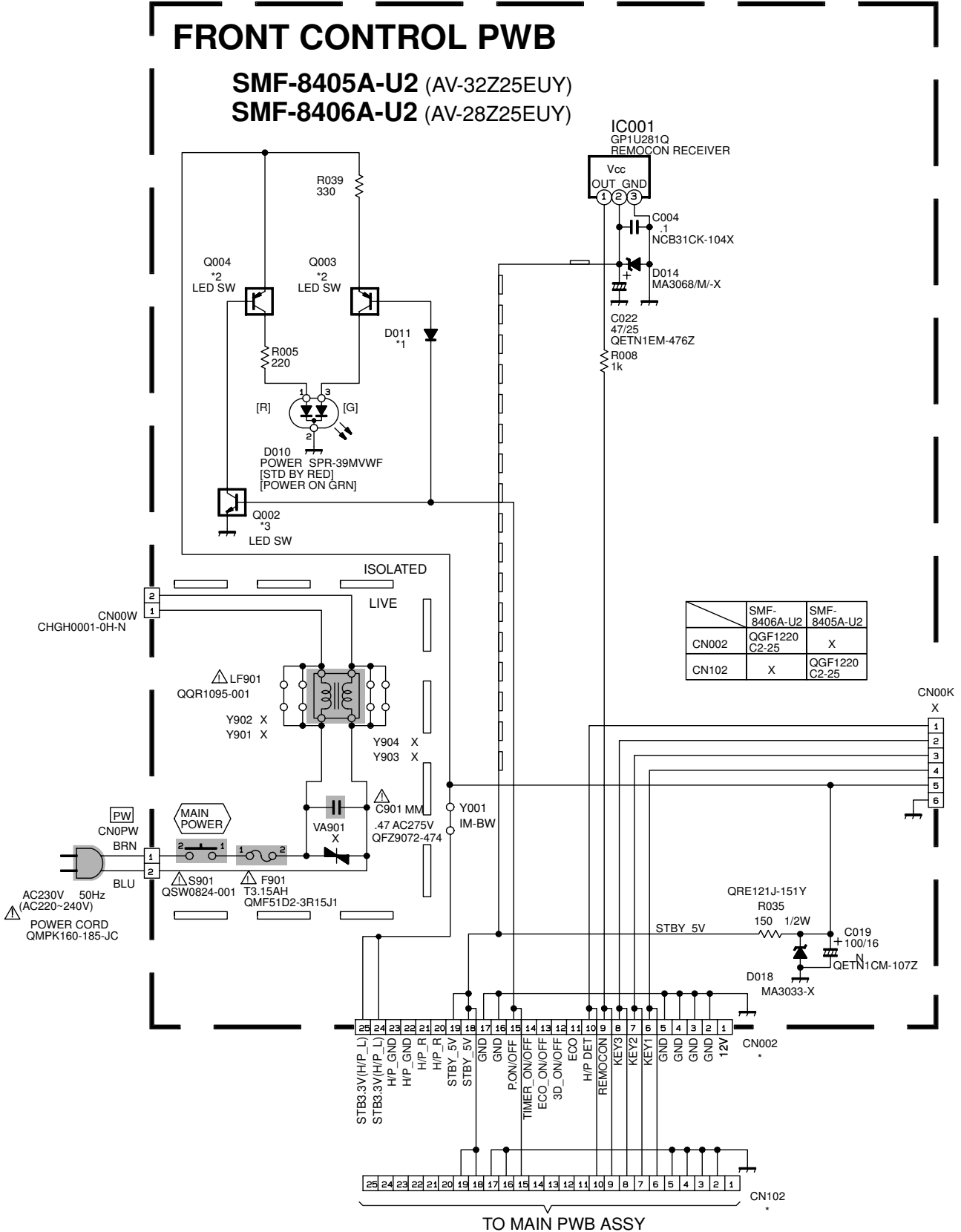

■ CHANGED ITEMS

- MAIN DIFFERENCE LIST (Page 5)
- USING PW BOARD (Page 33)
- PRINTED WIRING BOARD PARTS LIST [AV-32Z25EUY] (Page 38~51) / [AV-28Z25EUY] (Page 52~58)
- STANDARD CIRCUIT DIAGRAM (Page 2-5 ~ 2-24)

PART NAME	AV-32Z25EUY PWB ASS'Y		AV-28Z25EUY PWB ASS'Y	
	INCORRECT	CORRECT	INCORRECT	CORRECT
MAIN PWB	SMF-1406A	SMF-1406A-U2	SMF-1405A	SMF-1405A-U2
POWER&DEF.PWB	SMF-2406A	SMF-2406A-U2	SMF-2405A	SMF-2405A-U2
CRT SOCKET PWB	SMF-3406A	SMF-3406A-U2	SMF-3407A	SMF-3407A-U2
FRONT CONTROL PWB	SMF-8405A	SMF-8405A-U2	SMF-8405A (REPLACEMENT) →	SMF-8406A-U2 (Refer to Page 5)
SIDE CONTROL PWB	SMF-8106A	SMF-8106A-U2	SMF-8105A	SMF-8105A-U2
DOLBY PWB	SMF-0D401A	SMF0D401A-U2	SMF-0D401A	SMF0D401A-U2
MICOM PWB	SMF-0M403A	SMF0M403A-U2	SMF-0M403A	SMF0M403A-U2
AV SW PWB	SMF-0S402A (CHANGE) →	SMF0S403A-U2	SMF-0S402A (CHANGE) →	SMF0S403A-U2
100Hz PWB	SMF-0Z404A	SMF0Z404A-U2	SMF-0Z404A	SMF0Z404A-U2

■ PARTS LIST

● EXPLODED VIEW PARTS LIST (Page 34) [AV-32Z25EUY]

△	Ref. No.	Part No.		Part Name	Description
		INCORRECT	CORRECT		
	12	CHFD125-14BD-N	CHFD125-14BD	FFC WIRE	
	17	LC31205-001B	LC31205-002A-U	CONTROL SHEET	

● EXPLODED VIEW PARTS LIST (Page 36) [AV-28Z25EUY]

△	Ref. No.	Part No.		Part Name	Description
		INCORRECT	CORRECT		
	12	CHFD125-11BD-N	CHFD125-11BD	FFC WIRE	
	17	LC31205-001B	LC31205-002A-U	CONTROL SHEET	

● PRINTED WIRING BOARD PARTS LIST [AV-32Z25EUY]

POWER & DEF. P.W. BOARD ASS'Y (SMF-2406A-U2) (Page 40 ~ 42)

△	Symbol No.	Part No.		Part Name	Description
		SMF-2406A	SMF-2406A-U2		
	C2409	QFV71HJ-474Z	QFVF1HJ-474Z	MF CAP.	0.47 μ F 50V J
	C2410	QFV71HJ-474Z	QFVF1HJ-474Z	MF CAP.	0.47 μ F 50V J
	C2503	QFV71HJ-224Z	QFVF1HJ-224Z	MF CAP.	0.22 μ F 50V J
△	C2522	QFZ0200-123	QFZ0196-123	MPP CAP.	0.012 μ F 1.5kVH±3%
	C2959	QFV71HJ-684Z	QFVF1HJ-684Z	MF CAP.	0.68 μ F 50V J

AV SW P.W. BOARD ASS'Y (SMF0S403A-U2) (Page 48 ~ 49)

⚠	Symbol No.	Part No.		Part Name	Description
		SMF-0S402A	SMF0S403A-U2		
	R0156	NRSA63J-101X	NRSA63J-221X	MG R	220 Ω 1/16W J
	R0158	NRSA63J-101X	NRSA63J-221X	MG R	220 Ω 1/16W J
	C0156	—————	NDC31HJ-390X	C CAP.	39pF 50V J

● **PRINTED WIRING BOARD PARTS LIST [AV-28Z25EUY]**

POWER & DEF. P.W. BOARD ASS'Y (SMF-2405A-U2) (Page 55 ~ 56)

⚠	Symbol No.	Part No.		Part Name	Description
		SMF-2405A	SMF-2405A-U2		
	C2409	QFV71HJ-474Z	QFVF1HJ-474Z	MF CAP.	0.47 μ F 50V J
	C2410	QFV71HJ-474Z	QFVF1HJ-474Z	MF CAP.	0.47 μ F 50V J
	C2503	QFV71HJ-224Z	QFVF1HJ-224Z	MF CAP.	0.22 μ F 50V J
⚠	C2522	QFZ0200-113	QFZ0196-113	MPP CAP.	0.011 μ F 1.5kVH±3%
	C2959	QFV71HJ-684Z	QFVF1HJ-684Z	MF CAP.	0.68 μ F 50V J

● **PACKING PARTS LIST [AV-32Z25EUY] (Page 59)**

⚠	Ref. No.	Part No.		Part Name	Description
		INCORRECT	CORRECT		
	1	LC10101-017A	AEM1002-A79-E	PACKING CASE	
	3	LC11361-001C	LC11361-002C-U	CUSHION ASSY	

● **PACKING PARTS LIST [AV-28Z25EUY] (Page 59)**

⚠	Ref. No.	Part No.		Part Name	Description
		INCORRECT	CORRECT		
	1	LC10101-016A	AEM1002-B76-E	PACKING CASE	
	3	LC11318-002C	LC11318-004E-U	CUSHION ASSY	

● PRINTED WIRING BOARD PARTS LIST (REPLACEMENT)

[AV-28Z25EUY]

FRONT CONTROL P.W. BOARD ASS'Y (SMF-8406A-U2)(Page 58)

△ Symbol No.	Part No.	Part Name	Description
RESISTOR			
R8005	NRSA63J-221X	MG R	220Ω 1/16W J
R8008	NRSA63J-102X	MG R	1kΩ 1/16W J
R8035	QRE121J-151Y	C R	150Ω 1/2W J
R8039	NRSA63J-331X	MG R	330Ω 1/16W J
CAPACITOR			
C8004	NCB31CK-104X	C CAP.	0.1μF 16V K
C8019	QETN1CM-107Z	E CAP.	100μF 16V M
C8022	QETN1EM-476Z	E CAP.	47μF 25V M
△ C8901	QFZ9072-474	MM CAP.	0.47μFAC275V M
△ OR	QFZ9075-474	MPP CAP.	0.47μFAC275V M
DIODE			
D8010	SPR-39MVWF	LED	
D8011	MA111-X	SI.DIODE	
D8014	MA3068/M/-X	ZENER DIODE	
D8018	MA3033-X	ZENER DIODE	
TRANSISTOR			
Q8002	DTC124EKA-X	DIGI.TRANSISTOR	
Q8003	DTA124EKA-X	DIGI.TRANSISTOR	
Q8004	DTA124EKA-X	DIGI.TRANSISTOR	
IC			
IC8001	GP1U281Q	IR DETECT UNIT	
OTHERS			
	LC30349-001A-H	LED HOLDER	
	CEMG002-001Z	FUSE CLIP	x2
	QGF1220C2-25	FFC/FPC CONNE	
△ CN8002	QMF51D2-3R15J1	FUSE	3.15A
△ F8901	QQR1095-001	LINE FILTER	
△ LF8901	QSW0824-001	PUSH SWITCH	MAIN POWER
△ S8901			



JVC

VICTOR COMPANY OF JAPAN, LIMITED

AV & MULTIMEDIA COMPANY DISPLAY CATEGORY 12, 3-chome, Moriya-cho, kanagawa-ku, Yokohama, kanagawa-prefecture, 221-8528, Japan



Printed in Japan
0301 WPC
DP6061